

catalogo generale

eco**materiali**



CASALGRANDE
PADANA
Pave your way

INDICE PER SERIE
INDEX BY SERIES
INDEX PAR SÉRIE INDEX
NACH SERIE

Agorà	Granitogres	166	Meteor	Pietre native	68
Amazzonia	Pietre native	50	Mineral chrom	Pietre native	76
Antique wood	Granitoker	250	Natural slate	Granitogres	140
Architecture	Granitogres	332	Newood	Granitoker	268
Ardesia	Granitogres	154	Old season	Gresplus	414
Basaltina	Pietre native	118	Palatino	Gresplus	174
Beton	Granitoker	364	Parchi	Gresplus	282
Caleidoscopio	Ecogres	352	Patio	Gresplus	162
Cemento	Granitoker	372	Pietra baugé	Pietre native	82
Chalon	Pietre native	56	Pietra blue	Pietre native	128
Cotto cerato	Gresplus	418	Pietra piacentina	Pietre native	132
Earth	Granitoker	324	Pietre di paragone	Pietre native	42
Econcrete	Gresplus	392	Pietre di sardegna	Pietre native	88
Feel	Ecogres	402	Pietre etrusche	Pietre native	110
Granito 1	Granitogres	294	Pietre runiche	Granitogres	144
Granito 1Evo	Granitogres	290	Resina	Granitoker	380
Granito 2	Granitogres	302	Rocks	Gresplus	170
Granito 3	Granitogres	308	Spazio	Pietre Native	386
Granito 4	Granitogres	314	Steeltech	Granitoker	232
Kerblock	Pietre native	136	Stonewash	Granitoker	96
Lavagna	Pietre native	158	Tactile	Granitogres	436
Limestone	Pietre native	62	Tavolato	Granitoker	256
Living	Ecogres	406	Technic	Granitogres	426
Loft	Granitoker	396	Terre toscane	Pietre native	102
Marmogres	Granitogres	220	Titano	Granitogres	148
Marmoker	Granitoker	184	Ulivo	Granitoker	262
Marte	Granitogres	208	Unicolore	Granitogres	344
Metallica	Granitoker	238	Venezia	Ecogres	410
Metalwood	Granitoker	276			

ecoindex

- 4 Indice alfabetico articoli
Plain tiles alphabetical index
 Index alphabétique fonds
Grundfliesen in Alphabetisches Reihenfolge
- 8 Indice per formati
Index by size
 Index par taille
Index nach Format

ecobiosceramics

- 12 Bios ceramics
 14 Bios self-cleaning
 24 Bios antibacterial

36 eco

ecopietra

ecostone écopierre ökostein

- 42 Pietre di paragone
 50 Amazzonia
 56 Chalon
 62 Limestone
 68 Meteor
 76 Mineral chrom
 82 Pietra baugé
 88 Pietre di sardegna
 96 Stonewash
 102 Terre toscane
 110 Pietre etrusche
 118 Basaltina
 128 Pietra blue
 132 Pietra piacentina
 136 Kerblock
 140 Natural slate
 144 Pietre runiche
 148 Titano
 154 Ardesia
 158 Lavagna
 162 Patio
 166 Agorà
 170 Rocks
 174 Palatino

ecomarmo

ecomarble écomarbre ökomarmor

- 184 Marmoker
 208 Marte
 220 Marmogres

ecometallo

ecometal écométal ökometall

- 232 Steeltech
 238 Metallica

ecolegno

ecowood écobois ökoholz

- 250 Antique wood
 256 Tavolato
 262 Ulivo
 268 Newood
 276 Metalwood
 282 Parchi

ecogranito

ecogranite écogranit ökogranit

- 290 Granito 1Evo
 294 Granito 1
 302 Granito 2
 308 Granito 3
 314 Granito 4

ecocolore

ecocolour écouleur ökofarbe

- 324 Earth
 332 Architecture
 344 Unicolore
 352 Caleidoscopio

ecocemento

ecoconcrete écociment ökozement

- 364 Beton
 372 Cemento
 380 Resina
 386 Spazio
 392 Econcrete
 396 Loft
 402 Feel
 406 Living
 410 Venezia
 414 Old season
 418 Cotto cerato

ecotecnico

ecotechnique éco technique ökotchnik

- 426 Technic
 436 Tactile

ecoutilty

Caratteristiche tecniche

Technical features

Caractéristiques techniques

Technische Eigenschaften

444 **Granitogres**

448 **Pietre native**

450 **Granitoker**

452 **Gresplus**

454 **Ecogres**

456 Stonalizzazione

Shade variations

Variations d'ombre

Farbtonvarianten

457 Complementi in acciaio e alluminio

Accessories in steel and aluminium

Compléments en acier et en aluminium

Zusatzelemente aus Stahl und Aluminium

458 Voci di capitolato

Specifications

Cahier des charges

Ausschreibungstexte

460 Posa e manutenzione

Installation and maintenance

Pose et entretien

Verlegung und Pflege

ecoindexINDICE ALFABETICO ARTICOLI **PLAIN TILES** ALPHABETICAL INDEX |
INDEX ALPHABETIQUE FONDS GRUNDFLIESEN IN ALPHABETISCHES REIHENFOLGE**A**

Acquamarina	347
Adriano	176
Ajaccio	310
Alpi	172
Amalfi	305
Ande	172
Anice	355
Ankara	310
Antique Black	252
Antique Moka	252
Antique White	252
Antracite	356
Arabesque	191
Architecture Acid Green	338
Architecture Beige	337
Architecture Black	334
Architecture Cool Grey	334
Architecture Dark Brown	336
Architecture Dark Grey	334
Architecture Dark Ivory	336
Architecture Light Brown	336
Architecture Light Grey	334
Architecture Light Ivory	336
Architecture Medium Grey	335
Architecture Purple	338
Architecture Warm Grey	335
Architecture White	337
Ardesia Beige	156
Ardesia Bianco	156
Ardesia Grigio	156
Ardesia Nero	156
Ardesia Rosa	156
Ardesia Rosso	156
Argento	278
Arizona	296
Arkansas	296
Asiago	186
Atlante	172
Autumn	416
Avorio	357
Azul Bahia	212
Azul Macauba	212

B

Balder	146
Bardiglio Bianco	187
Bardiglio Imperiale	186
Baugé Antracite	84
Baugé Beige	84
Baugé Bianca	84
Baugé Grigia	84
Beton Dark	366
Beton Ivory	366
Beton Mud	366
Beton Sand	366
Beton Pearl	366
Betulla	357
Bianco Assoluto	347
Bianco Avorio	347
Bianco Avorio Tactile	438
Bianco B	347
Bianco Vietnam	191
Birimbau	188
Black Pearl	44
Blu	346
Blu Forte	346
Boston	292
Botticino	211
Breccia Argento	187
Breccia Carsica	190
Breccia Sarda	192
Bronzetto	210
Bronzo	278
Budapest	310
Budapest Tactile	438
Buxy	150

C

Caen	150
Caffè	354
Cala Luna	90
Calacatta Beige	223
Calacatta Grigio	223
Caligola	176
Canalgrande	412
Canova	187
Capalbio	112
Caprera	90
Caramel	357
Carbonio	278
Cardoso	150
Casablanca	311
Catalogna	298
Cemento Cassero Antracite	374
Cemento Cassero Beige	374
Cemento Cassero Bianco	375
Cemento Cassero Grigio	374
Cemento Rasato Antracite	374
Cemento Rasato Beige	374
Cemento Rasato Bianco	375
Cemento Rasato Grigio	374
Cervinia	305
Chalon Beige	58
Chalon Cream	58
Chalon Grey	58
Chalon Kaki	58
Chambrod	150
Champagne	151
Chicago	292
Cielo	355
Claudio	176
Cobalto	355
Cocco	357
Colorado	298
Corallo	356
Corinto	168
Cortina	304
Cotto Paglierino	420
Cotto Ramato	420
Cotto Rosato	420

Crema Marfil	211
Crema Select	189
Crema Supremo	222

D

Dakota	296
Denver	292
Domiziano	176
Dragon Beige	53
Dragon Black	52
Dragon Brown	52
Dragon Chocolate	52
Dragon Green	52
Dragon Grey	52
Dragon White	53

E

Earth Bianco	327
Earth Blu	326
Earth Brunello	326
Earth Grigio 1	327
Earth Grigio 2	327
Earth Grigio 3	326
Earth Grigio 4	326
Earth Metalred	326
Earth Tortora 1	327
Earth Tortora 2	327
Earth Tortora 3	327
Earth Tortora 4	326
Eco antracite	394
Eco beige	394
Eco bianco	394
Eco cenere	394
Eco grigio	394
Elatea	168
Eldorado	52
Emperador	210
Everest	297

F

Feel Beige	404
Feel Black	404
Feel Grey	404
Feel Olive	404
Feel Silver	404
Feel White	404
Ferro	240
Fiji	316
Fiorito	190
Fragola	357
Freyr	146

G

Gaiole	104
Gallipoli	305
Genova	304
Georgia	297
Ghiaccio	356
Giallo Ocra	348
Giallo Ocra Tactile	438
Giallo Siena	223
Giallo Striato	188
Giamaica	296
Grafite Marrone	190
Granita	356
Gré	44
Gré Bianco	44
Gré Nero	45
Greve	104
Grigio Aitos	45
Grigio Ash	150
Grigio Azzurro	347
Grigio Billiemi	190
Grigio Cenere	346
Grigio Egeo	211
Grigio Maggia	210
Grigio Marostica	210
Grigio Perla	346
Grigio Tao	44
Groenlandia	316

H

Hawaii	316
Helsinki	311
Himalaya	172

I

Iberia	298
Inox	240
Iridio	279
Ischia	120
Islanda	316

J

Jolie	191
Jura Beige	46
Jura Grigia	46

K

Kerblock Avorio	138
Kerblock Beige	138
Kerblock Nero	138
Kerblock Piombo	138

L

Labrador	297
Lavagna Bianca	160
Lavagna Grigia	160
Lavagna Nera	160
Lido	412
Limestone Beige	64
Limestone Grigio	64
Limestone Nero	64
Linosa	120
Lipari	120
Liquirizia	354
Living Beige	408
Living Black	408
Living Brown	408
Living Grey	408
Living Ice	408

Living Noisette	408
Living White	408
Loft Avorio	398
Loft Bianco	398
Loft Grigio	398
Loft Moka	398
Loft Nero	398
Loft Rosso	398
Luni	46

M

Madagascar	316
Madras Pink	212
Madrid	310
Madrid Tactile	438
Manciano	112
Marina	355
Marocco	298
Matraia	150
Megalopoli	168
Menta	355
Meteor Almond	71
Meteor Beige	71
Meteor Bianco	71
Meteor Brown	70
Meteor Grafite	70
Meteor Grigio	70
Meteor Nero	70
Meteor Noce	70
Meteor Perla	71
Meteor Rosso	70
Milano	304
Mineral Beige	78
Mineral Black	78
Mineral Brown	78
Mineral Gold	78
Mineral Grey	78
Mineral White	78
Minnesota	297
Mondo	146
Montepulciano	104
Monteriggioni	105
Montreal	310

N

Nebraska	297
Nero	346
Nero Acapulco	210
Nero Creta	186
Nero Marquinia	222
Nevada	297
New Blue Brut	130
New Blue Moon	130
New York	292
Newood Beige	271
Newood Black	270
Newood Brown	270
Newood Cream	270
Newood Grey	270
Newood Ivory	271
Newood Wengè	270
Newood White	271

O

Oceano	354
Ocra	356
Odino	146
Olimpo	186
Oliva	354
Onsernone	44
Ontario	296

P

Pack	355
Paestum	113
Palissandro	211
Panna	357
Pantelleria	120
Paonazetto	222
Patio Beige	164
Patio Black	164
Patio Brown	164
Patio Gold	164
Patio Grey	164
Patio White	164

P

Pennsylvania	222
Pevero	90
Pietra del Cardoso	44
Pietra di Vicenza	46
Pietra Piasentina	132
Pietra Piasentina New	46
Piombo	278
Pistacchio	354
Pitigliano	112
Platino	279
Porto Cervo	91
Porto Rotondo	91
Portoro	222
Pulpis Tortora	186
Punta Molarà	90

R

Raggio di Luna	211
Rame	240
Ramora Brown	210
Resina Black	382
Resina Grey	382
Resina Havana	382
Resina Tabacco	382
Resina White	382
Rialto	412
Rosa Antico	348
Rosa Portogallo	212
Rosato	189
Rosso Laguna	223
Rosso Mattone	348
Rosso Pompei	348
Rosso Selenio	356

S

Sahara	296
Saint Laurent	188
San Casciano	105
San Gimignano	104
San Marco	412
Santa Fiora	112
Saturnia	113
Seattle	292
Sequoia	284
Shanghai	311
Shanghai Tactile	438
Siena	304
Silicio	278
Silvia Oro	192
Slate Beige	142
Slate Black	142
Slate Gold	142
Slate Green	142
Slate Grey	142
Slate Red	142
Smeraldo	354
Sovana	112
Sparta	168
Spazio Antracite	388
Spazio Argento	388
Spazio Beige	388
Spazio Bianco	389
Spazio Bronzo	388
Spazio Grigio	389
Spazio Perla	388
Spazio Tabacco	388
Spazio Tortora	389
Spring	416
Statuario Grigio	187-191
Statuario Oro	187
Steeltech Antracite	234
Steeltech Beige	234
Steeltech Corten	234
Steeltech Grigio	234
Stintino	90
Stromboli	120
Summer	416

T

Tarquinià	113
Tavolara	90
Tavolato Antracite	258
Tavolato Grano	258
Tavolato Marrone Chiaro	258
Tavolato Marrone Medio	258
Tavolato Marrone Scuro	258
Tavolato Sbiancato	259
Terranova	298
Thassos	211
Thor	146
Tiberio	176
Tibet	298
Tokyo	310
Torino	304
Travertino Bianco	186
Travertino Miele	188
Travertino Moka	188
Travertino Noce	189
Travertino Romano	188
Travertino Santa Caterina	189
Travertino Titanium	190
Tucson	292
Tuscania	113

U

Ulivo Grigio	264
Ulivo Noce	264
Ulivo Panna	264
Ulivo Tortora	264

V

Vals	46
Venezia	304
Verde	347
Verde Aver	190
Verde Guatemala	212
Verde India	222
Verrazzano	104
Veselye	192
Violet	346
Volpaia	104
Vulcano	120
Vulci	112

W

Wash Brown	98
Wash Cream	98
Wash Grey	98
Winter	416

Y

Yellowstone	284
-------------	-----

Z

Zebrino	187
Zinco-Titanio	240

90x180

Marmoker	184
Pietre di Paragone	42
Resina	380
Stonewash	96

45x180

Stonewash	96
-----------	----

30x180

Stonewash	96
-----------	----

22,5x180

Stonewash	96
-----------	----

90x90

Architecture	332
Marmoker	184
Pietre di Paragone	42
Pietre di Sardegna	88
Resina	380
Steeltech	232
Stonewash	96

45x90

Amazzonia *	50
Architecture	332
Basaltina	118
Marmoker	184
Metalwood	276
Newood	268
Pietre di Paragone	42
Pietre di Sardegna	88
Pietre Etrusche	110
Resina	380
Steeltech	232
Terre Toscane	102

45x45

Amazzonia	50
Basaltina	118
Granito 1evo	290
Meteor	68
Palatino	174
Pietre di Sardegna	88
Pietre Etrusche	110
Spazio	386

22,5x90

Newood	268
--------	-----

15x90

Architecture	332
Metalwood	276
Newood	268
Tavolato	256

11x90

Newood	268
--------	-----

75,5x151

Beton	364
-------	-----

75,5x75,5

Beton	364
Cemento	372
Spazio	386

37,5x75,5

Beton	364
Cemento	372
Spazio	386

60x120

Basaltina	118
Cemento	372
Chalon	56
Earth	324
Marte	208
Pietre di Paragone	42
Pietre di Sardegna	88
Pietre Etrusche	110
Resina	380
Stonewash	96
Unicolore	344

59x118

Marmoker	184
----------	-----

29,5x118

Marmoker	184
----------	-----

* 20 mm **30x120**

Earth	324
Tavolato	256
Ulivo	262

20x120

Antique Wood	250
Marte	208
Metalwood	276
Newood	268
Tavolato	256
Ulivo	262

15x120

Antique Wood	250
Earth	324
Metalwood	276
Newood	268
Tavolato	256
Ulivo	262

60x60

Amazzonia	50
Architecture	332
Basaltina	118
Cemento	372
Chalon	56
Earth	324
Econcrete	392
Granito 1evo	290
Granito 4	314
Kerblock *	136
Lavagna	158
Limestone	62
Living	406

60x60

Loft	396
Marmogres	220
Marte	208
Metallica	238
Metalwood	276
Meteor	68
Mineral Chrom	76
Parchi *	282
Pietra Baugé *	82
Pietra Blue	128
Pietre di Paragone	42
Pietre di Sardegna	88
Pietre Etrusche	110
Resina	380
Spazio	386
Steeltech	232
Stonewash	96
Terre Toscane	102
Titano	148
Unicolore	344

59x59

Marmoker	184
----------	-----

30x60

Amazzonia	50
Architecture	332
Basaltina	118
Cemento	372
Chalon	56
Earth	324
Econcrete	392
Feel	402
Granito 1evo	290
Granito 4	314
Lavagna	158
Limestone	62

30x60

Living	406
Loft	396
Marmogres	220
Marte	208
Metallica	238
Metalwood	276
Meteor	68
Mineral Chrom	76
Palatino	174
Pietra Baugé	82
Pietra Blue	128
Pietra Piasentina	132
Pietre di Paragone	42
Pietre di Sardegna	88
Pietre Etrusche	110
Resina	380
Spazio	386
Terre Toscane	102
Titano	148
Unicolore	344

20x60

Marte	208
-------	-----

29,5x59

Marmoker	184
----------	-----

15x60

Architecture	332
Marte	208
Meteor	68
Pietre di Sardegna	88
Pietre Etrusche	110
Tavolato	256

10x60

Marte	208
Metalwood	276

9,8x59

Marmoker	184
----------	-----

30x30

Agorà	166
Amazzonia	50
Architecture	332
Ardesia	154
Basaltina	118
Cotto Cerato	418
Granito 1	294
Granito 1evo	290
Granito 2	302
Granito 3	308
Lavagna	158
Marmogres	220
Marte	208
Meteor	68
Natural Slate	140
Old Season	414
Palatino	174
Pietre di Sardegna	88
Pietre Etrusche	110
Pietre Runiche	144
Rocks	170
Spazio	386
Terre Toscane	102
Unicolore	344

15x30

Agorà	166
Ardesia	154
Mineral Chrom	76
Natural Slate	140
Old Season	414
Pietre Runiche	144
Rocks	170

15x15

Agorà	166
Ardesia	154
Granito 1	294
Lavagna	158
Marte	208
Meteor	68
Mineral Chrom	76
Natural Slate	140
Pietre di Sardegna	88
Pietre Etrusche	110
Pietre Runiche	144

41,5x41,5

Feel	402
Living	406
Parchi	282
Venezia	410

33x33

Caleidoscopio	352
Feel	402
Living	406
Venezia	410

12,5x25

Granito 1	294
Unicolore	344

40x40

Granito 1	294
Marte	208
Unicolore	344

20x40

Patio	162
-------	-----

20x20

Caleidoscopio	352
Granito 1	294
Patio	162
Unicolore	344

10x20

Caleidoscopio	352
Granito 1	294
Unicolore	344

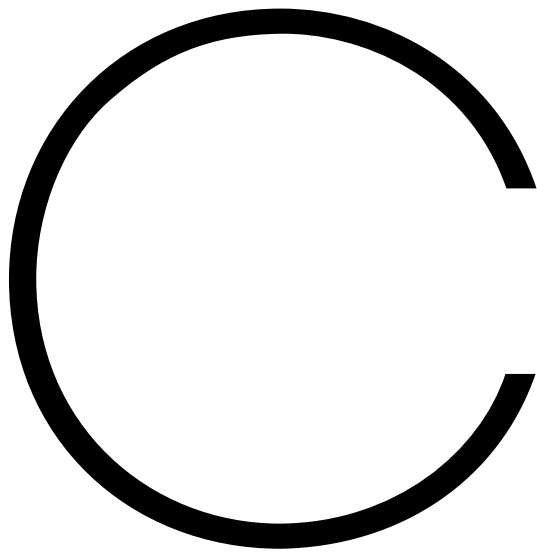
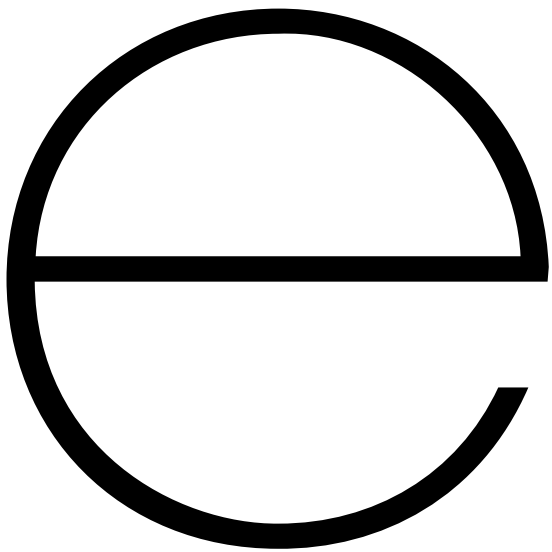

bios. ceramics®

CERAMICHE BIOATTIVE

Innovativa tipologia di prodotti eco-compatibili, in grado di interfacciarsi autonomamente con l'ambiente, per generare una serie di processi virtuosi, quali in particolare, reazioni di tipo chimico e biologico, capaci di ricadute positive in termini antibatterici, di abbattimento degli agenti inquinanti, di autopulibilità delle superfici e capaci di contribuire in maniera determinante all'innalzamento della qualità del microambiente (interno o esterno) in cui gli elementi ceramici vengono messi in opera. I processi avvengono grazie alla particolare natura dei materiali e dei trattamenti, senza alcuna necessità di alimentazione elettrica, energetica o del rinnovo dei composti necessari a sostenere nel tempo la reazione.

BIOACTIVE CERAMICS

Innovative kind of environment-friendly products that can independently interface with the environment to create a number of virtuous processes, such as chemical and biological reactions that have an air pollutant reducing and antibacterial effect and trigger the self-cleaning of the surfaces, thus remarkably contributing to improving the quality of the (internal or external) micro-environment in which the ceramics are installed. Such processes take naturally place thanks to the materials and treatments, without any electricity or energy, and without having to renew the compounds necessary to prolongue the reaction.



Bios Ceramics®, è l'esclusiva generazione di ceramiche bioattive, certificate ed ecocompatibili, frutto di un master agreement siglato tra il Centro Ricerche Casalgrande Padana e Toto, leader assoluto nel settore dei prodotti sanitari e pioniere nella tecnologia fotocatalitica a marchio Hydrotec.

La produzione si articola nell'ambito di due linee estremamente specializzate, in grado di rispondere a qualsiasi esigenza applicativa in interni ed esterni, associando al meglio, in funzione delle specifiche condizioni di impiego, caratteristiche antibatteriche, autopulenti e di riduzione degli agenti inquinanti.

Una proposta trasversale e diversificata, che accanto alle eccellenti prestazioni garantite, permette di soddisfare la creatività di progettisti e clienti grazie alle ricercate finiture e ai diversi formati disponibili su tutta la gamma Casalgrande Padana.

L'offerta comprende:

Bios Self-Cleaning®, pensata e sviluppata per la realizzazione di rivestimenti esterni di facciata. Grazie allo speciale trattamento basato sulla tecnologia Hydrotec®, in presenza di luce solare Bios Self-Cleaning® attiva una reazione in grado di abbattere non solo i batteri ma soprattutto gli inquinanti presenti nell'aria e decompone lo sporco che si deposita sulla superficie delle piastrelle, in modo che venga rimosso dall'acqua piovana, grazie alla super-idrofilia della superficie ceramica.

Bios Antibacterial®, destinata alla realizzazione di pavimenti e rivestimenti con assolute proprietà antibatteriche, capace di abbattere al 99,9% i principali ceppi batterici presenti negli ambienti : escherichia coli, Pseudomonas aeruginosa.

Bios Ceramics® is the exclusive range of certified eco-friendly bioactive ceramics resulting from a master agreement between the Casalgrande Padana Research Centre and Toto, the world-leading sanitary ware manufacturer and pioneer in photocatalysis technology with its Hydrotec brand.

The range consists of two highly specialised series that meet any interior or exterior application requirement, associating antibacterial, self-cleaning, and pollutant reduction properties according to the specific conditions of use.

A cross-cutting and diversified range, which, in addition to its excellent performance guaranteed, gives free rein to designers' and customers' creativity, thanks to its refined finishes and different sizes available for the entire Casalgrande Padana range.

The range includes:

Bios Self-Cleaning® designed and developed for façade cladding. The special treatment based on the Hydrotec® technology allows Bios Self-Cleaning® to activate a reaction in the presence of sunlight. This reaction reduces air pollutants and decomposes dirt deposits, which are washed away by rainwater, thanks to the superhydrophilicity of the ceramic surface.

Bios Antibacterial®, intended for creating flooring and wall coverings with certified antibacterial properties, which can remove up to 99.9% of the main bacterial strains, such as Escherichia coli and Pseudomonas aeruginosa.



Bios Ceramics® est une nouvelle génération de céramiques bioactives certifiées et éco-compatibles, fruit de la collaboration entre le Centre de Recherches Casalgrande Padana et Toto, leader absolu dans le secteur des produits sanitaires et pionnier dans la technologie photocatalytique, avec la marque Hydrotect.

Deux lignes ultra-spécialisées composent cette gamme en mesure de répondre à chaque exigence d'application, à l'extérieur comme à l'intérieur, en associant à la perfection des caractéristiques antibactériennes, autonettoyantes et d'élimination des agents polluants, en fonction des circonstances d'utilisation.

Une offre transversale et diversifiée, qui permet, en plus de performances excellentes et garanties, de laisser libre cours à la créativité des concepteurs et des clients grâce à des finitions raffinées et les différents formats disponibles sur toute la gamme Casalgrande Padana.

Elle comprend :

Bios Self-Cleaning®, conçue et développée pour la réalisation de revêtements extérieurs de façade. Grâce à un traitement spécial basé sur la technologie Hydrotect®, Bios self-cleaning® déclenche en présence de lumière solaire une réaction capable d'éliminer les polluants présents dans l'air, de décomposer les saletés déposées en surface et de les éliminer grâce à l'eau de pluie et aux propriétés ultra-hydrophiles de la surface céramique.

Bios Antibacterial®, destinée à la réalisation de sols et de revêtements dotés de propriétés antibactériennes élevées, permet d'éliminer 99,9 % des principales souches bactériennes présentes dans l'environnement, comme Escherichia coli ou Pseudomonas aeruginosa.

Bios Ceramics® ist eine exklusive Generation an bioaktiven, zertifizierten und umweltfreundlichen Keramikprodukten – hervorgegangen aus einer Rahmenvereinbarung zwischen dem Forschungszentrum Casalgrande Padana und Toto, dem absoluten Marktführer im Bereich von Gesundheitsprodukten und einem Pionier im Bereich der photocatalytischen Technologie mit dem Markenzeichen Hydrotect.

Die Produktion stützt sich auf zwei hochspezialisierte Anlagen, die jeder Anwendungsanforderung im Innen- und Außenbereich gerecht werden und dem Produkt je nach spezifischen Anwendungsbedingungen antibakterielle, selbstreinigende und schadstoffreduzierende Eigenschaften verleihen können.

Ein transversales und vielfältiges Angebot, das es neben seinen hervorragenden und garantierten Eigenschaften möglich macht, die Kreativität von Planern und Kunden dank der ausgesuchten Oberflächenbearbeitungen und der unterschiedlichen Formate des Gesamtangebots von Casalgrande Padana zufrieden zu stellen.

Das Angebot umfasst:

Bios Self-Cleaning®, konzipiert und entwickelt für den Bau von Fassaden-Außenverkleidungen. Dank der Spezialbehandlung auf Grundlage der HYDROTECT®-Technologie ruft Bios Self-Cleaning® im Sonnenlicht eine Reaktion hervor, die die vorhandene Luftverschmutzung bindet und den sich auf den Fliesenoberflächen absetzenden Schmutz zersetzt. Dieser kann dann in der Folge dank der super-hydrophilen Keramikoberfläche vom Regenwasser abgewaschen werden.

Bios Antibacterial®, konzipiert für das Verlegen von Bodenbelägen und Wandverkleidungen mit herausragenden antibakteriellen Eigenschaften, die bis zu 99,9 % der in geschlossenen Räumen auftretenden hauptsächlich Bakterienstämme abtöten können: Escherichia coli, Pseudomonas aeruginosa.

bios self-cleaning[®]

Una soluzione innovativa per i rivestimenti di facciata, in grado di qualificare gli involucri architettonici con elevate prestazioni di autopulizia e di abbattimento degli agenti inquinanti.

An innovative façade cladding solution that ensures high self-cleaning and pollution abatement performance for architectural envelopes.

Une solution innovante pour les revêtements de façade, en mesure de donner aux enveloppes architecturales d'excellentes performances d'autonettoyage et d'élimination des agents polluants.

Eine innovative Lösung für Fassadenverkleidungen, die Gebäudehüllen durch verbesserte selbstreinigende Eigenschaften und die Fähigkeit zum Abbau von Schadstoffen aufwertet.

PROPRIETÀ SUPER IDROFILE SUPER-HYDROPHILIC PROPERTIES PROPRIÉTÉ SUPER-HYDROPHILE SUPER HYDROPHILE EIGENSCHAFTEN



Lastra ceramica tradizionale
Traditional ceramic slab
Dalle céramique ordinaire
Traditionelle Keramikplatte

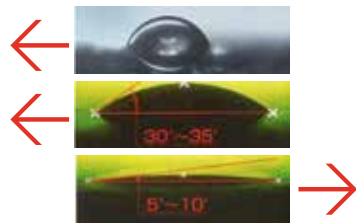

Lastra ceramica trattata Bios
Self-Cleaning[®]
Bios Self-Cleaning[®] ceramic slab
Dalle céramique traitée avec
Bios Self-Cleaning[®]
Mit Bios Self-Cleaning[®]
behandelte Keramikplatte





unicolore bios bianco assoluto cm 10x60 - 4"x23⁵/₈"



LA TECNOLOGIA HYDROTECT®

La tecnologia **HYDROTECT®** viene utilizzata su licenza da oltre 100 produttori di tutto il mondo, nei più differenti settori applicativi, dall'industria automobilistica alle costruzioni. Detentore del brevetto è il gruppo giapponese TOTO, leader globale nel settore delle tecnologie fotocatalitiche, con il quale **Casalgrande Padana** ha sottoscritto un Master Agreement. Grazie a questa tecnologia le ceramiche **Bios Self-Cleaning®** utilizzate nei rivestimenti di facciata ed involucri ventilati, offrono significative risposte in termini di capacità autopulente e di abbattimento dei NOx (ossidi e miscele di azoto, tra i principali inquinanti dell'atmosfera urbana). In particolare, **Bios Self-Cleaning®** aggiunge alle caratteristiche estetiche e prestazionali dei rivestimenti ceramici in grès porcellanato, il drastico abbattimento degli interventi di pulizia e manutenzione delle superfici, garantendo un sensibile risparmio in termini economici e il mantenimento delle qualità e dell'aspetto del manufatto architettonico.

LE CARATTERISTICHE BIOATTIVE PER I RIVESTIMENTI ESTERNI

L'esclusiva formulazione di **Bios Self-Cleaning®** è a base di biossido di titanio (TiO₂), una sostanza naturale, non nociva, tradizionalmente utilizzata come pigmento bianco e per confezionare additivi alimentari, dentifrici, prodotti cosmetici eccetera.

Il biossido di titanio conferisce alle superfici **Bios Self-Cleaning®**:

- caratteristiche fotocatalitiche che, in presenza di irraggiamento luminoso, consentono di decomporre le sostanze organiche e gli inquinanti depositati sulle piastrelle, garantendo proprietà autopulenti e di purificazione dell'aria.

- caratteristiche di super-idrofilia, che ne esaltano la capacità di auto detergersi.

Tanto è maggiore l'irraggiamento con luce UV della superficie trattata, tanto diminuisce il suo angolo di contatto con l'acqua, che tende addirittura a zero dopo un ragionevole intervallo di tempo. L'acqua si spande e dilava con facilità. In pratica, all'azione del biossido di titanio che disgrega i depositi organici presenti sulla superficie trattata, grazie alla fotocatalisi, si aggiunge quella idrofila, che consente all'acqua piovana di detergere le piastrelle, asportando le macchie dalla loro superficie.

HYDROTECT® TECHNOLOGY

The **HYDROTECT®** technology has been licensed out to over 100 manufacturers all over the world in the most diverse areas of application, from car-making to building. The owner of the patent is the Japanese holding TOTO, a global leader in photo-catalytic technology, with which **Casalgrande Padana** has entered into a Master Agreement.

With the **HYDROTECT®** technology, the **Bios Self-Cleaning®** ceramics in facings and ventilated walls provide important responses through their self-cleaning and NOx-reduction properties (NOx are nitrogen oxides and compounds, largely responsible for urban air pollution).

In particular, **Bios Self-Cleaning®** can combine the well-known aesthetic features and performance of unglazed stoneware ceramic facings with a dramatic reduction in the need to clean or maintain the surfaces, which translates into remarkable savings and a long-lasting quality and appearance of the architectural features.

BIOACTIVE PROPERTIES FOR EXTERIOR FACINGS

The exclusive formulation of **Bios Self-Cleaning®** contains titanium dioxide (TiO₂), a natural substance traditionally used as a white pigment and to make food additives, toothpaste, makeup and so on. Because of its titanium dioxide content, **Bios Self-Cleaning®** can perform to the highest standards, especially as a facing, to which it adds:

- photo-catalytic properties, which, when triggered by light, can break up the organic substances and pollutants on the tile surface for a self-cleaning, air cleansing effect.

- super-hydrophilic properties, which make the most of its self-cleaning properties.

The higher the UV light on the treated surface, the smaller its angle of contact with water, which after a reasonable time is next to zero. This means that the water will easily spread and wash off. Basically, the effect of the titanium dioxide that breaks up the organic matter on the treated surface is supported, through photo-catalysis, by the hydrophilic effect, whereby rainwater washes off any stain from the tile surface.

LA TECHNOLOGIE HYDROTECT®

Plus de 100 fabricants dans le monde entier utilisent, sous licence, la technologie **HYDROTECT®**, ceci dans les secteurs les plus variés, de l'industrie automobile au bâtiment. Le groupe japonais TOTO est titulaire du brevet et leader mondial dans le secteur des technologies photocatalytiques. **Casalgrande Padana** a signé un Master Agreement avec le groupe Toto.

Grâce à la technologie **HYDROTECT®**, les céramiques **Bios Self-Cleaning®**, utilisées pour les revêtements de façades traditionnelles et/ou ventilées, offrent des réponses significatives en termes de capacité autonettoyante et d'abattement des NOx (oxydes et mélanges d'azote, parmi les principaux polluants de l'air en milieu urbain).

En particulier, **Bios Self-Cleaning®** est en mesure d'allier les caractéristiques esthétiques et les performances des revêtements céramiques en grès cérame, à une importante diminution des opérations d'entretien et de nettoyage des surfaces, en garantissant pendant de longues années des économies en termes de coûts et du maintien de la qualité et de l'aspect du bâtiment.

LES CARACTÉRISTIQUES BIOACTIVES POUR LES REVÊTEMENTS D'EXTÉRIEUR

La formule exclusive de **Bios Self-Cleaning®** est à base de dioxyde de titane (TiO₂), une substance naturelle, couramment utilisée en tant que pigment blanc mais aussi pour fabriquer des additifs alimentaires, dentifrices, produits cosmétiques, etc. Grâce au dioxyde de titane, **Bios Self-Cleaning®** est en mesure de garantir d'excellentes prestations, notamment comme revêtement de façade, en conférant à celle-ci :

- Des caractéristiques photocatalytiques, qui en présence d'un rayonnement lumineux, permettent de décomposer les substances organiques et les polluants qui se déposent sur la surface des carreaux, en garantissant des propriétés autonettoyantes et de purification de l'air.

- Des caractéristiques super-hydrophiles qui exaltent les propriétés autonettoyantes. Plus le rayonnement UV sur la surface traitée est intense, plus

l'angle de contact entre l'eau et la surface diminue, et peut même arriver à zéro après un certain laps de temps. Ainsi, en glissant sur la surface, l'eau la nettoie plus facilement. En pratique, l'action photocatalytique du dioxyde de titane dégrade les dépôts organiques présents sur la surface traitée, et conjuguée aux propriétés hydrophiles, l'eau de pluie nettoie les carreaux en éliminant ainsi les salissures.

DIE HYDROTECT®-TECHNOLOGIE

Die Technologie **HYDROTECT®** wird unter Lizenz von mehr als 100 Produzenten in aller Welt verwendet und zwar in unterschiedlichsten Anwendungsbereichen, von der Automobilindustrie bis zum Bauwesen. Der Patentinhaber ist der japanische Konzern TOTO, das weltweit führende Unternehmen im Bereich der fotokatalytischen Technologien, mit dem **Casalgrande Padana** ein Master Agreement abgeschlossen hat.

Dank der **HYDROTECT®** Technologie bieten die für die Gestaltung von Fassaden und hinterlüfteten Fassaden verwendeten Keramikprodukte **Bios Self-Cleaning®** bedeutende Lösungen in puncto selbstreinigende Fähigkeit und NOx-Abbau (Oxide und Stickstoffmischungen, die zu den Hauptschadstoffen der Stadtluft gehören). Insbesondere ist **Bios Self-Cleaning®** in der Lage, die schon bekannten ästhetischen Eigenschaften und Leistungen der keramischen Feinsteinzeugbeläge mit einer drastischen Reduzierung der Reinigungs- und Instandhaltungseingriffe

an den Oberflächen zu bereichern und garantiert dabei über viele Jahre hinweg eine merkbare Kosteneinsparung und das Aufrechterhalten der Vorzüge und des Erscheinungsbildes der architektonischen Struktur.

BIOAKTIVE EIGENSCHAFTEN FÜR EXTERNE VERKLEIDUNGEN

Die exklusive Formel von **Bios Self-Cleaning®** baut auf Titandioxyd (TiO₂) auf, ein natürlicher Stoff, der traditionell als weißes Pigment verwendet wird und für die Zubereitung von Lebensmittelzusatzstoffen, Zahnpasta, Kosmetika, usw. Dank Titandioxyd garantiert **Bios Self-Cleaning®** ausgezeichnete Leistungen und verleiht besonders als Fassadenverkleidung folgende Eigenschaften:

- Fotokatalytische Eigenschaften, die bei Lichteinfall die Zersetzung der organischen Stoffe und der auf der Fliesenoberfläche abgesetzten Schadstoffe ermöglichen und Eigenschaften der Selbstreinigung und Luftreinigung garantieren.
- Super hydrophile Eigenschaften, welche die selbstreinigende Fähigkeit zusätzlich betont. Je größer die UV-Bestrahlung der behandelten Oberfläche, umso kleiner wird ihr Kontaktwinkel mit dem Wasser, der nach einem vernünftigen Zeitintervall sogar zum Nullwert neigt. Das bedeutet, dass sich das Wasser leicht ausbreitet und spült.

Praktisch wird die Wirkung von Titandioxyd, das die organischen Ablagerungen an der behandelten Oberfläche zersetzt, dank der Fotokatalyse mit einer hydrophilen Wirkung bereichert, mit der das Regenwasser die Fliesen reinigen und die Flecken von den Oberflächen entfernen kann.

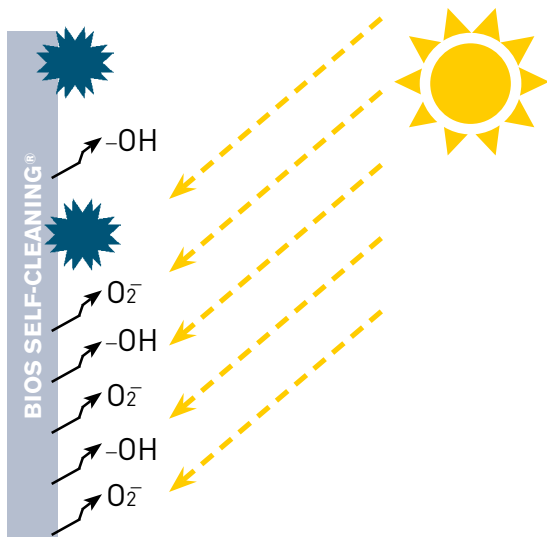

Quando la luce del sole (raggi UVA) irradia la superficie di **Bios Self-Cleaning®** si genera ossigeno attivo (O₂⁻, -OH)
 When sunlight (UVA rays) hits the surface of the **Bios Self-Cleaning®**, active oxygen (O₂⁻, -OH) forms
 La lumière du soleil (rayons UVA) qui rayonne sur la surface de **Bios Self-Cleaning®** génère de l'oxygène actif (O₂⁻, -OH)
 Wenn das Sonnenlicht (UVA-Strahlen) die Oberflächen von **Bios Self-Cleaning®** bestrahlt, wird Aktivsauerstoff erzeugt (O₂⁻, -OH)

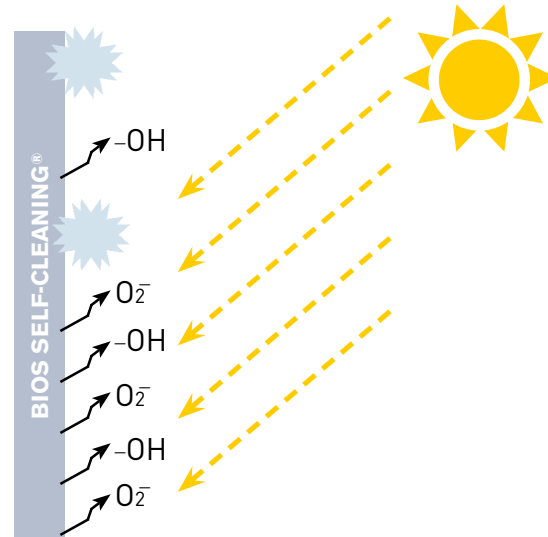

L'ossigeno attivo (O₂⁻, -OH) decompone lo sporco in sostanze meno aderenti
 Active oxygen (O₂⁻, -OH) decomposes dirt into less adhesive substances
 L'oxygène actif (O₂⁻, -OH) décompose les salissures en substances moins adhérentes
 Der Aktivsauerstoff (O₂⁻, -OH) zersetzt den Schmutz in weniger haftfähige Stoffe



L'acqua piovana si espande sulla superficie di **Bios Self-Cleaning®** generando un sottilissimo strato che deterge ed elimina lo sporco precedentemente decomposto dall'ossigeno attivo
 Rainwater spreads onto the **Bios Self-Cleaning®** surface, forming an extremely thin layer that cleanses and removes the dirt that has been decomposed by the active oxygen
 L'eau de pluie glisse sur la surface de **Bios Self-Cleaning®** en constituant une fine couche d'eau qui nettoie et élimine les salissures précédemment décomposées par l'oxygène actif
 Das Regenwasser breitet sich auf der Oberfläche von **Bios Self-Cleaning®** aus und erzeugt einen hauchdünnen Film, der den zuvor vom Aktivsauerstoff zersetzten Schmutz reinigt und beseitigt

 Sporco Dirt Salissures Schmutz

 Sporco decomposto Decomposed dirt Salissures décomposées Zersetzter Schmutz

EFFICACIA DEL PROCESSO AUTOPULENTE

Le prestazioni autopulenti di Bios Self-Cleaning® sono estremamente efficaci e certificate, ma è importante sottolineare che:

- **NON** sono in grado di rimuovere completamente i depositi che eccedono la proprietà autopulente, quali macchie che aderiscono alle facciate rapidamente, massicciamente e tenacemente, come i sigillanti al silicone
- **NON** sono in grado di rimuovere ruggine ed efflorescenze
- **NON** si attiva il processo autopulente in assenza di pioggia ed esposizione ai raggi UV.

EFFECTIVENESS OF THE SELF-CLEANING PROCESS

The self-cleaning property of Bios Self-Cleaning® is extremely effective and certified, but you should keep in mind that:

- **THEY CANNOT** remove all the stains that surpass their self-cleaning properties, such as stains that stick to the facing quickly, massively and stubbornly, e.g. silicone sealants.
- **THEY CANNOT** remove rust or crystals.
- **NO** self-cleaning process may take place without rain or exposure to UV rays.

Macchia organica 1 Organic stain 1 Tache organique 1 Organischer Fleck 1	Macchia organica 2 Organic stain 2 Tache organique 2 Organischer Fleck 2	Macchia non organica 1 Non organic stain 1 Tache non organique 1 Nicht organischer Fleck 1	Macchia non organica 2 Non organic stain 2 Tache non organique 2 Nicht organischer Fleck 2
Macchia oleosa, polvere e fuliggine, gas di scarico	Sigillante al silicone, graffiti, vernice, alveari, ragnatele	Sabbia, fango	Ruggine, efflorescenze, iridescenze
Greasy stain, dust and soot, exhaust gases	Silicone sealant, graffiti, paint, beehives, spider webs	Sand, mud	Rust, efflorescences, iridescent spots
Tache graisseuse, poussière et suie, gaz d'échappement	Colle silicone, graffiti, peinture, ruches, toiles d'araignée	Sable, boue	Rouille, efflorescences, irisations
Ölfleck, Staub und Russt, Abgas	Silikondichtmasse, Graffiti, Lack, Bienenstöcke, Spinnennetze	Sand, Schlamm	Rust, Ausblühungen, Irideszenzen



Efficacia autopulente di Bios Self-Cleaning®
Self-Cleaning property of Bios Self-Cleaning®
Efficacité autonettoyante de Bios Self-Cleaning®
Wirksamkeit der Selbstreinigung von Bios Self-Cleaning®

Efficace	Difficile da rimuovere completamente mediante l'effetto autopulente	Efficace	Non efficace
Effective	Cannot be completely removed by self-cleaning	Effective	Ineffective
Efficace	Difficile à éliminer complètement au moyen de l'action autonettoyante	Efficace	Non efficace
Wirksam	Schwierig komplett zu entfernen durch die selbstreinigende Wirkung	Wirksam	Unwirksam

EFFICACITÉ DU PROCESSUS AUTONETTOYANT

Quoique la capacité autonettoyante de Bios Self-Cleaning® soit extrêmement efficace, outre à être certifiée, il convient de souligner que :

- son action **NE PEUT** éliminer totalement les dépôts allant au-delà de sa capacité autonettoyante, telles les taches qui adhèrent aux façades de manière rapide, massive et tenace, comme par exemple les colles silicone
- son action **NE PEUT** éliminer la rouille et les efflorescences
- le processus autonettoyant **NE PEUT S'ACTIVER** en absence de pluie et d'exposition aux rayons UV.

WIRKSAMKEIT DES SELBSTREINIGUNGSPROZESSES

Die selbstreinigenden Leistungen von Bios Self-Cleaning® sind extrem wirksam und zertifiziert, doch Folgendes ist unbedingt zu unterstreichen:

- **NICHT** komplett entfernt werden Ablagerungen, welche die Selbstreinigungsfähigkeiten überschreiten, so z.B. Flecken, die rasch massiv und hartnäckig an Fassaden anhaften wie Silikondichtmassen.
- **NICHT** entfernt werden Rost und Ausblühungen
- **NICHT** aktiviert wird der Selbstreinigungsprozess ohne Regen und UV-Bestrahlung.

Macchia organica 2
Organic stain 2
Tache organique 2
Organischer Fleck 2

Perché sigillanti al silicone e graffiti sono difficili da rimuovere con l'effetto autopulente?
Why are silicone sealants and graffiti hard to remove by the self-cleaning reaction?
Pourquoi l'effet autonettoyant élimine-t-il difficilement les colles silicone et les graffitis?
Weshalb sind Silikondichtmassen und Graffiti mit der selbstreinigenden Wirkung schwer zu entfernen?

La loro potente forza adesiva supera la proprietà autopulente di **Bios Self-Cleaning®**. Inoltre, deviano i raggi UV dalla superficie delle piastrelle, pertanto è difficile che su tale superficie si generi l'ossigeno attivo.

Their powerful adhesive strength exceeds the self-cleaning power of **Bios Self-Cleaning®**. In addition, they divert the UV rays from the tile surface, so active oxygen can hardly form on such surfaces.

Leur force d'adhésion très élevée est supérieure à la capacité autonettoyante de **Bios Self-Cleaning®**. Par ailleurs, vu qu'ils dévient les rayons UV de la surface des carreaux, il est donc difficile que de l'oxygène actif puisse se former sur ce type de surface.

Ihr kräftiges Haftvermögen übertrifft die selbstreinigende Fähigkeit von **Bios Self-Cleaning®**. Außerdem weisen sie die UV-Strahlen von der Fliesenoberfläche ab, sodass sich kaum Aktivsauerstoff auf ihnen bildet.

Macchia non organica 2
Non organic stain 2
Tache non organique 2
Nicht organischer Fleck 2

Perché ruggine ed efflorescenze NON vengono lavate via dall'effetto autopulente?
Why are rust and efflorescences NOT washed off by the self-cleaning reaction?
Pourquoi l'effet autonettoyant N'ÉLIMINE-T-IL ni la rouille ni les efflorescences ?
Weshalb werden Ausblühungen von der selbstreinigenden Wirkung NICHT weggespült?

Se ruggine ed efflorescenze aderiscono alla superficie delle piastrelle grazie all'ausilio di sostanze intermedie quali macchie e depositi oleosi, **Bios Self-Cleaning®** è in grado di rimuoverle. Se invece aderiscono direttamente, le proprietà di decomposizione di **Bios Self-Cleaning®** NON sono efficaci su queste sostanze inorganiche.

If the rust and efflorescences are glued to the tile surface by such mediums as greasy stains or spots, then **Bios Self-Cleaning®** can remove them. If they are directly stuck to the surface, then the decomposing properties of **Bios Self-Cleaning®** ARE NOT effective on such inorganic substances.

Si la rouille et les efflorescences adhèrent à la surface des carreaux au moyen de substances intermédiaires, comme par exemple par le biais de taches et de dépôts gras, **Bios Self-Cleaning®** est en mesure de les éliminer. En revanche, si ces substances adhèrent directement aux carreaux, les propriétés de décomposition de **Bios Self-Cleaning®** NE SONT PAS efficaces sur ces substances non organiques.

Wenn Rost und Ausblühungen mit Zwischenstoffen wie Flecken bzw. Ölablagerungen an der Fliesenoberfläche anhaften, kann **Bios Self-Cleaning®** sie entfernen. Haften sie dagegen direkt an, dann sind die Zersetzungsfähigkeiten von **Bios Self-Cleaning®** auf solchen anorganischen Stoffen unwirksam.

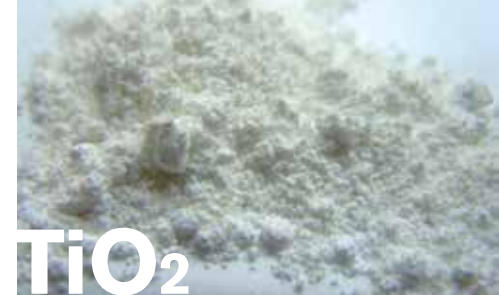

L'ABBATTIMENTO DEGLI AGENTI INQUINANTI E LA PURIFICAZIONE DELL'ARIA

Una delle principali cause di inquinamento dell'atmosfera, che minaccia concretamente la salute dell'uomo e dell'ambiente, è costituita dai NOx (ossidi di azoto sottoprodotti dei processi di combustione), generati dagli automezzi, dal riscaldamento domestico e da alcuni processi industriali.

L'ossigeno attivo ($-OH$, O_2^-) prodotto dagli involucri di facciata rivestiti con **Bios Self-Cleaning®** ossida i NOx in sostanze non nocive (NO_3^- nitrato solubile in acqua), che vengono rimosse attraverso il dilavamento dell'acqua piovana. Grazie alla loro scarsa quantità, i NO_3^- ossidati dalla reazione fotocatalitica non hanno alcuna influenza sull'acidificazione del suolo.

Le prestazioni di abbattimento dei NOx garantite da **Bios Self-Cleaning®** offrono un apprezzabile contributo al miglioramento della qualità ambientale degli insediamenti urbani. Basti pensare che un rivestimento di 1000 metri quadrati di facciata con **Bios Self-Cleaning®** ha la capacità di purificare l'aria in misura paragonabile a un bosco delle dimensioni di un campo da calcio, oppure di eliminare gli ossidi di azoto (NOx) emessi da 70 automobili nel corso di un'intera giornata.

POLLUTANT-REDUCTION AND AIR-CLEANSING PROPERTIES

One of the main sources of atmospheric pollution, which really threatens human and environmental health, are NOx (nitrogen oxides as combustion by-products) from vehicles, heating and some industrial processes.

The active oxygen ($-OH$, O_2^-) produced by the **Bios Self-Cleaning®** facings oxidises the NOx into non-harmful substances (NO_3^- water-soluble nitrate), which are washed off by rainwater. The NO_3^- oxidised by the photo-catalytic reaction is too little to have any influence on soil acidification.

The guaranteed NOx-reducing properties of **Bios Self-Cleaning®** make an appreciable contribution to the improvement of the environmental standards of urban settlements. Just think that a 1000 sqmt **Bios Self-Cleaning®** facing can purify the air like a wood the size of a football pitch or remove the nitrogen oxides (NOx) emitted by 70 cars during one day.

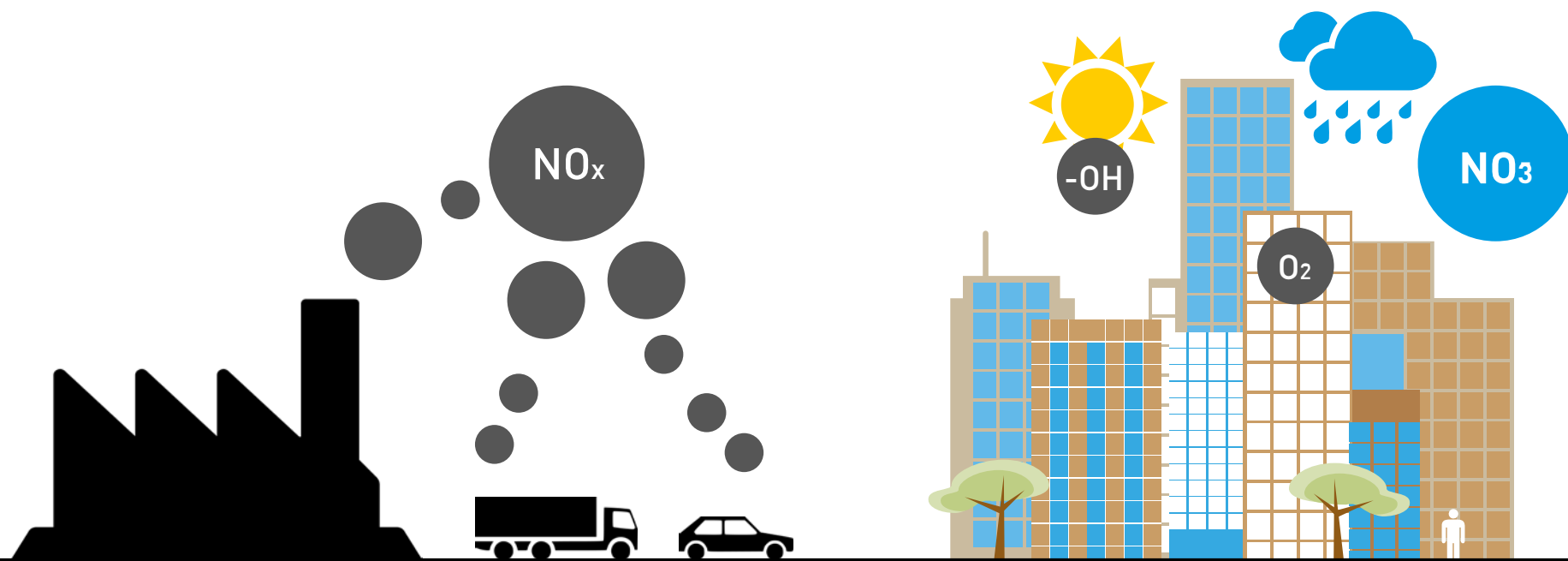



bios
self-cleaning[®]

ABATTEMENT DES AGENTS POLLUANTS ET PURIFICATION DE L'AIR

Une des principales causes de la pollution de l'air, qui par ailleurs menace concrètement la santé de l'homme et l'environnement, est représentée par les NOx (oxydes d'azote, sous-produits du processus de combustion) émis par les véhicules, le chauffage domestique et certains processus industriels. L'oxygène actif ($-OH$, O_2^-) généré par les façades revêtues des produits **Bios Self-Cleaning**[®], oxyde les NOx en substances non nocives (NO_3^- nitrate hydrosoluble) qui sont ensuite éliminés par l'eau de pluie. Grâce à leur faible quantité, les NO_3^- oxydés par la réaction photocatalytique n'ont aucune incidence sur l'acidification du sol.

La capacité d'abattement des NOx effectuée par **Bios Self-Cleaning**[®] offre une contribution appréciable à l'amélioration de la qualité de l'environnement des centres urbains. Il suffit de penser qu'une façade de 1000 m² revêtue de **Bios Self-Cleaning**[®] a une capacité de purifier l'air comparable à celle d'une forêt de la taille d'un terrain de football, ou d'éliminer les oxydes d'azote (NOx) émis pendant 24 heures par 70 véhicules.

DER ABBAU DER SCHADSTOFFE UND DIE REINIGUNG DER LUFT

Eine der Hauptursachen der Luftverschmutzung, die unsere Gesundheit und unsere Umgebung konkret bedrohen, sind die NOx (Stickstoffoxyde als Nebenprodukte des Verbrennungsprozesses), die von Fahrzeugen, Raumheizungen und einigen Industrieverfahren erzeugt werden.

Der von mit **Bios Self-Cleaning**[®] verkleideten Fassaden erzeugte Aktivsauerstoff ($-OH$, O_2^-) oxydiert die NOx in unschädliche Stoffe (NO_3^- wasserlösliches Nitrat), die durch Auswaschung mit Regenwasser entfernt werden. Dank ihrer geringen Menge haben durch fotokatalytische Reaktion oxydierten NO_3^- keinerlei Einfluss auf die Bodensäuerung. Die von **Bios Self-Cleaning**[®] garantierten NOx-Abbauleistungen bieten einen schätzenswerten Beitrag zur Verbesserung der Qualität der Umwelt in Wohngebieten. Man denke allein schon daran, dass eine 1000 Quadratmeter große mit **Bios Self-Cleaning**[®] verkleidete Fassade die Fähigkeit besitzt, die Luft in einem Ausmaß zu reinigen, das mit einem Wald in der Größe eines Fußballplatzes vergleichbar ist, oder die Stickstoffoxyde (NOx) zu beseitigen, die von 70 Autos im Laufe eines ganzen Tages freigesetzt werden.

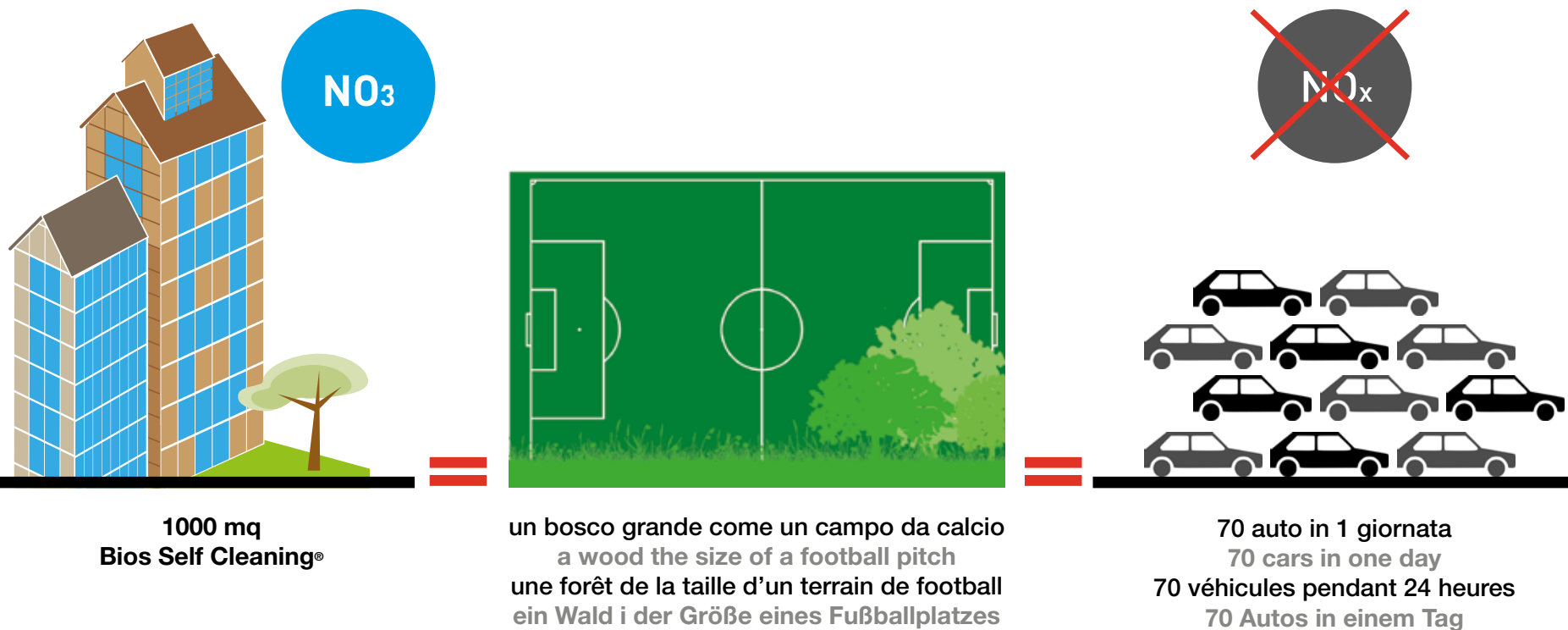



bios unicolore iperbianco cm 60x120 - 23⁵/₈"x47¹/₈"



DURATA DELLE PRESTAZIONI

Grazie a una severa serie di prove di laboratorio è stato possibile dimostrare che le prestazioni di **Bios Self-Cleaning®** non si riducono nel tempo. La durabilità è stata confermata sottoponendo le lastre ceramiche a un test d'invecchiamento accelerato in condizioni equiparabili a 50 anni di esposizione all'esterno. Per quanto concerne la resistenza al calpestio, va evidenziato come la tecnologia HYDROTECT®, inglobata a caldo sulla superficie di **Bios Self-Cleaning®** durante il ciclo di produzione industrializzata, sia in grado di assicurare nel tempo le sue caratteristiche rispettando le prescrizioni relative alle sollecitazioni da traffico leggero e le relative avvertenze di manutenzione.

CERTIFICAZIONI

Le prestazioni della tecnologia HYDROTECT®, con cui sono trattate le lastre ceramiche in grès porcellanato **Bios Self-Cleaning®**, sono certificate secondo le più importanti norme internazionali.

LONG-TERM EFFICIENCY

A number of strict lab tests proved that the efficiency of **Bios Self-Cleaning®** does not diminish over time. The durability of the ceramic slabs has been confirmed by an accelerated aging test, the conditions of which were comparable to 50 years' outdoor exposure. Note that in heavy-traffic areas, the HYDROTECT® technology, if hot embedded in the **Bios Self-Cleaning®** surface during the industrial production process, will perform well over time and will fulfil the applicable light traffic resistance and maintenance requirements.

CASALGRANDE PADANA'S PRODUCT RANGES

The performance of the HYDROTECT® technology, applied to **Bios Self-Cleaning®** unglazed stoneware ceramic slabs, is certified according to the most important international standards.

DURÉE DES TRAITEMENTS

Les nombreux essais rigoureux menés en laboratoire ont permis de démontrer la très longue durée de vie des propriétés de **Bios Self-Cleaning®**. Cette durabilité a été confirmée en faisant subir des tests de vieillissement accéléré aux dalles céramiques, ceci à des conditions comparables à 50 ans d'exposition aux agents atmosphériques.

En ce qui concerne la résistance au bruit d'impact, il faut souligner que la technologie HYDROTECT®, englobée à chaud sur la surface de **Bios Self-Cleaning®** pendant le cycle de fabrication, est en mesure de garantir longuement ses caractéristiques, en respectant les prescriptions sur les sollicitations dérivant d'un trafic léger et les règles d'entretien correspondantes.

CERTIFICATIONS

Les propriétés de la technologie HYDROTECT®, qui caractérisent les dalles céramiques en grès cérame **Bios Self-Cleaning®**, sont certifiées selon les plus importantes normes internationales.

DAUERHAFTIGKEIT DER LEISTUNGEN

Dank einer Reihe strenger Labortests konnte nachgewiesen werden, dass die Leistungen von **Bios Self-Cleaning®** im Laufe der Zeit nicht nachlassen. Die Dauerhaftigkeit wurde bestätigt, indem die Keramikplatten einem beschleunigten Alterungstest unter Verhältnissen ausgesetzt wurden, die mit einer 50jährigen Exposition im Freien vergleichbar sind. Was die Begehungsfestigkeit betrifft, ist zu sagen, dass die während des industriellen Produktionsprozesses warm in die Oberfläche von **Bios Self-Cleaning®** eingearbeitete HYDROTECT® Technologie in der Lage ist, ihre Leistungen dauerhaft zu sichern und die Vorschriften für leichte Verkehrsbeanspruchungen und die entsprechenden Instandhaltungshinweise einzuhalten.

ZERTIFIZIERUNGEN

Die Leistungen der HYDROTECT® Technologie, mit der die Keramikplatten aus **Bios Self-Cleaning®** Feinsteinzeug behandelt werden, sind nach den wichtigsten internationalen Normen zertifiziert.

bios HYDROTECT™ **antibacterial®**

Bios Antibacterial® è la linea di prodotti da rivestimento e pavimentazione in gres porcellanato capaci di abbattere al 99,9% i quattro principali ceppi batterici presenti negli ambienti confinati: *Staphylococcus aureus*, *Escherichia coli*, *Pseudomonas aeruginosa*, *Enterococcus faecalis*.

La tecnologia **HYDROTECT®** sfrutta le caratteristiche antibatteriche del biossido di titanio, un materiale naturale che non rilascia alcuna emissione nociva e anche negli ambienti interni consente di ridurre notevolmente le sostanze dannose per la salute dell'uomo, rendendo gli ambienti più salubri ed eliminando allo stesso tempo i cattivi odori.

Bios Antibacterial® is the range of porcelain stoneware flooring and wall covering products that can remove up to 99.9% of the four most common bacterial strains in confined environments, i.e.: *Staphylococcus aureus*, *Escherichia coli*, *Pseudomonas aeruginosa*, and *Enterococcus faecalis*.

The **HYDROTECT®** technology exploits the antibacterial properties of titanium dioxide, a natural material that doesn't release any harmful emission and that, in interior applications, allows for a considerable reduction of harmful substances, thereby ensuring a healthier environment while eliminating odours.

Bios Antibacterial® est une ligne de produits de revêtement et de sols en grès cérame, en mesure d'éliminer 99,9 % des quatre principales souches bactériennes présentes dans les espaces confinés. *Staphylococcus aureus*, *Escherichia coli*, *Pseudomonas aeruginosa*, *Enterococcus faecalis*.

La technologie **HYDROTECT®** utilise les caractéristiques antibactériennes du dioxyde de titane, matériau naturel qui ne produit aucune émission nocive et qui, à l'intérieur, permet de réduire considérablement la quantité de substances nocives pour la santé de l'homme, en assainissant les environnements et en éliminant aussi les mauvaises odeurs.

Bios Antibacterial® ist eine Produktlinie an Verkleidungen und Bodenbelägen aus Feinsteinzeug, die in der Lage ist, bis zu 99,9 % der vier hauptsächlich, in geschlossenen Räumen auftretenden Bakterienstämme abzutöten: *Staphylococcus aureus*, *Escherichia coli*, *Pseudomonas aeruginosa*, *Enterococcus faecalis*.

Die **HYDROTECT®**-Technologie nutzt die antibakteriellen Eigenschaften von Titandioxid, einem natürlichen Material, das keine schädlichen Emissionen freisetzt und die Möglichkeit verleiht, auch in Innenräumen für den Menschen schädliche Substanzen erheblich zu reduzieren. Damit trägt es zu einer gesünderen und gleichzeitig von unangenehmen Gerüchen befreiten Umgebung bei.





Emergency Salam Surgery Centre di Khartoum

CAUSE ED EFFETTI DEI BATTERI NEGLI AMBIENTI

Lo *Staphylococcus aureus*, l'*Escherichiacoli*, lo *Pseudomonas aeruginosa* e l'*Enterococcus faecalis*, sono i principali responsabili delle infezioni che si registrano in ambito ospedaliero e sono stati adottati come indicatori standard perché rappresentano la categoria più aggressiva, in alcuni casi super resistente anche agli antibiotici.

Quando un prodotto può definirsi antibatterico

Dopo severe prove di laboratorio, **Bios Antibacterial® HYDROTECT** è risultato altamente efficace, in quanto capace di abbattere del 99,9% i quattro principali ceppi batterici presenti negli ambienti confinati: *Staphylococcus aureus*, *Enterococcus faecalis*, *Escherichia coli*, *Pseudomonas aeruginosa*.

Nella pratica il 100% di antibattericità non può essere assicurato, la soglia di efficacia è stata quindi fissata dai ricercatori di tutto il mondo a oltre il 90%, perché solo a questi livelli si può registrare una riduzione realmente significativa dei batteri. Per questo motivo, in termini di efficacia antibatterica, la comunità scientifica non prende in considerazione valori inferiori alla soglia del 90% e i prodotti che non raggiungono questo livello non possono essere definiti antibatterici.

La ricerca ha inoltre evidenziato che **Bios Antibacterial® HYDROTECT** in presenza di umidità, tradizionale terreno fertile per lo sviluppo della flora batterica, vede addirittura amplificare i propri effetti benefici.

Va comunque evidenziato come la tecnologia **Bios Antibacterial® HYDROTECT**, pur essendo capace di abbattere al 99,9% i 4 principali ceppi batterici presenti negli ambienti e ridurre la crescita virale, non possa garantire in assoluto l'immunità da infezioni. Si consiglia pertanto, in funzione delle specifiche destinazioni d'uso degli ambienti, di sottoporre le superfici ad appropriati cicli di pulizia e disinfezione.

LE PROPRIETÀ ANTIODORE

I cattivi odori sono tra le cause più invalidanti della qualità degli ambienti, oltre che segnale tangibile di bassi livelli di igiene dell'aria e delle superfici.

Nei locali bagno i cattivi odori vengono generati dalla combinazione tra urea, germi e batteri, che producono ammoniaca e trimetilammia.

Effetti analoghi possono attivarsi nelle cucine, causati dalla reazione con microresidui organici. Inoltre, sempre nei bagni e a bordo piscina la concentrazione di sebo e residui cutanei, in combinazione con i germi, dà luogo alla formazione di macchie e depositi viscosi che, oltre al degrado nell'aspetto dei rivestimenti, possono ridurre le caratteristiche antiderapanti delle superfici e la sicurezza al calpestio.

In tutti questi casi, l'effetto antibatterico di **Bios Antibacterial® HYDROTECT**, aiuta a eliminare i cattivi odori e a mantenere valide le caratteristiche antiderapanti delle piastrelle anche in assenza totale di luce, offrendo garanzie nel più ampio spettro.

CAUSES AND EFFECTS OF BACTERIA IN THE ENVIRONMENT

Staphylococcus aureus, *Escherichia coli*, *Pseudomonas aeruginosa* and *Enterococcus faecalis* are largely responsible for hospital-acquired infections and have been taken as standard indicators, because they are the most aggressive class of bacteria, which sometimes can even be resistant to antibiotics.

When a product can be called antibacterial

After strict lab tests, **Bios Antibacterial® HYDROTECT** turned out to be extremely effective, as it can remove 99.9% of the main four bacterial strains living in confined areas: *Staphylococcus aureus*, *Enterococcus faecalis*, *Escherichia coli*, *Pseudomonas aeruginosa*.

As a matter of fact, a 100% anti-bacterial effect cannot be ensured, so the effectiveness threshold has been set by researchers all over the world at over 90%, because only at such levels can a really significant reduction in bacteria be measured.

That's why in terms of antibacterial effectiveness the scientific community will not take into account any rating under 90% and products that fail to achieve such level may not be called antibacterial.

In addition, research has shown that **Bios Antibacterial® HYDROTECT** needs no light to be activated, and in a humid environment, which is traditionally a fertile ground for the growth of bacterial flora, its beneficial effects are even greater.

Note, however, that, even if capable of removing 99.9% of the 4 main bacterial strains living in the environment and reducing viral growth, the **Bios Antibacterial® HYDROTECT** technology cannot ensure perfect immunity to infections. Therefore, depending on the way a place is to be used, the surfaces should be treated with appropriate cleaning and disinfection procedures.

DEODORISING PROPERTIES

Bad smells are some of the factors that most deteriorate the quality of an environment, as well as being a tangible sign of a low level of air and surface hygiene. In bathrooms, bad smells are generated by a combination of urea, germs and bacteria that produce ammonia and trimethylamine. Similar effects may be had in kitchens as a reaction with organic micro-residues. In addition, also in bathrooms or poolside, a concentration of sebum and shed skin cells, combined with germs, forms stains and slippery spots that, as well as deteriorating the appearance of a facing, may reduce the anti-slipping properties of the surfaces and their safety when walked over.

In all these cases, the antibacterial effect of **Bios Antibacterial® HYDROTECT** helps remove bad smells and retain the anti-slipping properties of the tiles even without any light, for perfect safety.

CAUSES ET EFFETS DES BACTÉRIES DANS LE MILIEU AMBIANT

Le *Staphylococcus aureus*, l'*Escherichia coli*, le *Pseudomonas aeruginosa* et l'*Enterococcus faecalis* sont les principaux responsables des infections enregistrées en milieu hospitalier. Ils ont été adoptés comme indicateurs standard car ce sont les souches les plus agressives, dans certains cas même résistantes aux antibiotiques.

QUAND UN PRODUIT PEUT ÊTRE DÉFINI COMME ANTIBACTÉRIEN ?

Après de rigoureux essais en laboratoire, **Bios Antibacterial® HYDROTECT** résulte extrêmement efficace, étant capable d'abattre 99,9% des quatre principales souches bactériennes présentes dans les espaces fermés : *Staphylococcus aureus*, *Enterococcus faecalis*, *Escherichia coli*, *Pseudomonas aeruginosa*.

Dans la pratique, étant difficile d'assurer des propriétés 100% antibactéricides, la communauté scientifique mondiale a fixé le seuil d'efficacité à plus de 90%, car c'est seulement à ce niveau que l'on peut enregistrer une réduction vraiment significative des bactéries. Pour cette raison, il faut souligner qu'en termes d'efficacité antibactérienne, la communauté scientifique ne prend même pas en considération les valeurs inférieures à 90%, et donc les produits qui n'atteignent pas cette limite ne peuvent en aucun cas être définis comme antibactériens. La recherche a également montré que **Bios Antibacterial® HYDROTECT** n'a pas besoin de lumière pour s'activer, et qu'en présence d'humidité, facteur propice au développement de la flore bactérienne, ses effets bénéfiques augmentent ultérieurement. Il faut souligner que même si la technologie **Bios Antibacterial® HYDROTECT** est capable d'abattre 99,9% des 4 principales souches bactériennes et de réduire leur croissance, elle ne peut toutefois garantir une immunité totale contre les infections. Il est donc conseillé, en fonction de chaque contexte d'utilisation spécifique, de soumettre les surfaces à des cycles de nettoyage et de désinfection adéquats.

LES PROPRIÉTÉS ANTI-ODEURS

Les mauvaises odeurs sont une des causes qui nuisent le plus à la qualité de l'air et sont aussi le signe tangible du bas niveau d'hygiène de l'air et des surfaces. Dans les salles de bains, les mauvaises odeurs sont générées par la combinaison entre l'urée, les germes et les bactéries, qui produisent de l'ammoniac et de la triméthylamine. Des effets analogues peuvent se produire en cuisine, dus à la réaction avec des micro résidus organiques. Par ailleurs, en salle de bains ou sur le bord des piscines, la concentration de sébum et de résidus cutanés, en combinaisons aux germes, donne lieu à la formation de taches et de dépôts visqueux, qui outre à dégrader l'aspect des revêtements, peuvent réduire les caractéristiques antiglisse des surfaces, et donc la sécurité des personnes. L'effet antibactérien de **Bios Antibacterial® HYDROTECT** aide toujours à éliminer les mauvaises odeurs et à préserver les caractéristiques antiglisse des carreaux, même en l'absence totale de lumière, en offrant des garanties à large spectre.

URSACHEN UND AUSWIRKUNGEN VON BAKTERIEN IN RÄUMEN

Die *Staphylococcus aureus*, *Escherichia coli*, *Pseudomonas aeruginosa* und *Enterococcus faecalis* sind die Hauptverantwortlichen der Infektionen, die sich in Krankenhausbereichen ereignen und wurden als Standard-Anzeiger übernommen, da sie die aggressivste Kategorie darstellen, die in einigen Fällen sogar gegen Antibiotika resistent ist.

WANN KANN EIN PRODUKT ALS ANTIBAKTERIELL BEZEICHNET WERDEN

Nach strengen Labortests hat sich **Bios Antibacterial® HYDROTECT** als höchst wirksam erwiesen, da das Produkt die vier in angrenzenden Bereichen vorhandenen wichtigsten Bakterienstämme zu 99,9% abbaut: *Staphylococcus aureus*, *Enterococcus faecalis*, *Escherichia coli*, *Pseudomonas aeruginosa*. In der Praxis kann eine zu 100% bakterientötende Wirkung nicht zugesichert werden, sodass die Wirksamkeitsschwelle von den Forschern aller Welt auf über 90% festgelegt wurde, denn nur in diesem Ausmaß kann eine wirklich bedeutende Reduzierung der Bakterien festgestellt werden. Aus diesem Grund berücksichtigt die wissenschaftliche Gemeinschaft in Hinsicht auf die antibakterielle Wirksamkeit keine Werte unter 90% und Produkte, die dieses Niveau nicht erreichen, können nicht als antibakteriell bezeichnet werden. Die Forschung hat außerdem festgestellt, **Bios Antibacterial® HYDROTECT** kein Licht benötigt, um aktiv zu werden und bei Feuchtigkeit, einem bekanntlich begünstigenden Zustand für die Entwicklung von Bakterienflora, die vorteilhaften Wirkungen sogar noch verstärkt. Es ist auf jeden Fall zu sagen, dass die Technologie **Bios Antibacterial® HYDROTECT** trotz ihrer Fähigkeit, die 4 wichtigsten in der Umgebung vorhandenen Bakterienstämme zu 99,9% abzubauen und die Virenwucherung zu reduzieren, die Immunität gegenüber Infektionen nicht absolut garantieren kann. Deshalb wird empfohlen, auf den Oberflächen in Funktion der spezifischen Einsatzbedingungen der Räume angemessenen Reinigungs- und Desinfektionszyklen vorzunehmen.

DIE GERUCHHEMMENDEN EIGENSCHAFTEN

Schlechte Gerüche gehören zu den Ursachen, die der Qualität der Räume am meisten schaden und sind außerdem ein offensichtliches Zeichen geringer Hygieneniveaus in der Luft und auf den Flächen. Im Badezimmer werden schlechte Gerüche von der Kombination zwischen Urin, Keimen und Bakterien verursacht, die Ammoniak und Trimethylamin erzeugen. Gleiche Folgen können sich in Küchen durch die Reaktion mit organischen Mikrorückständen ergeben. Außerdem bilden sich in Badezimmern und an Schwimmbadrandern durch die Konzentration von Hauttalg und Hautrückständen in Kombination mit Keimen Flecken und schlüpfrige Ablagerungen, die nicht nur die Auskleidungen unschön machen, sondern auch die rutschhemmenden Eigenschaften der Oberflächen und die Trittsicherheit reduzieren. In allen diesen Fällen hilft die antibakterielle Wirkung von **Bios Antibacterial® HYDROTECT**, die schlechten Gerüche zu beseitigen und die rutschhemmenden Eigenschaften der Fliesen zu bewahren, auch ganz ohne Licht und bietet deshalb eine Garantie in einem ganz breiten Spektrum.





marte bios botticino *levigata, bocciardato* cm 30x60 - 11³/₄"x25³/₈", 12"x24", 60x60 - 25³/₈"x25³/₈"



Staphylococcus aureus



Escherichia coli



Pseudomonas aeruginosa

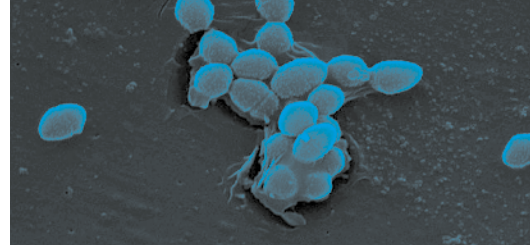

Enterococcus faecalis

STAPHYLOCOCCUS AUREUS

Lo Staphylococcus aureus è un batterio Gram positivo di forma sferica. Il suo sviluppo ha luogo fra 10°C e 45°C con un optimum di temperatura compreso tra i 30°C e i 37°C; per quanto riguarda il pH, fra 4 e 9 con un optimum fra 7 e 7,5. Pur non essendo sporigeni gli stafilococchi mostrano una notevole resistenza a condizioni ambientali sfavorevoli. È diffuso in generale nell'acqua, sulla pelle e nelle mucose. Introdotto nel nostro organismo, può generare infezioni di varia natura. Le infezioni da Staphylococcus aureus acquisite in ambiente ospedaliero in genere sono causate da stipti resistenti a vari chemioterapici e si manifestano sovente in forma epidemica. L'insorgere di queste epidemie in particolari reparti può rappresentare un evento di particolare gravità che pone seri problemi profilattici e terapeutici.

Staphylococcus is a spherical-shaped Gram-positive bacterium. It develops at a temperature of 10°C to 45°C, with optimum temperature being 30°C to 37°C; pH must be 4 to 9, with optimum pH being 7 to 7.5. Even if not sporogenic, staphylococci are extremely resistant to unfavourable environmental conditions. Usually widespread in water, skin and mucous membranes. If it enters our organism, it can induce a wide range of infections. Hospital-acquired infections with Staphylococcus aureus are usually caused by chemotherapeutic-resistant cells and often come in the form of veritable epidemics. In some wards, the outbreak of such epidemics may be an extremely challenging event that

may raise serious prophylactic and therapeutic problems.

Le Staphylococcus aureus est une bactérie de forme sphérique à Gram positif. Son développement a lieu entre 10 °C et 45 °C avec une température optimale comprise entre 30 °C et 37 °C ; en ce qui concerne le pH, il se multiplie à un pH entre 4 et 9, le pH optimal étant compris entre 7 et 7,5. Bien qu'il ne s'agisse pas d'un microorganisme sporogène, le staphylocoque présente une résistance remarquable aux conditions ambiantes défavorables. On le trouve surtout dans l'eau, sur la peau et les muqueuses. Une fois dans notre organisme, il peut causer différents types d'infection. En milieu hospitalier, les infections à Staphylococcus aureus sont généralement causées par des souches résistantes à différentes substances chimiothérapeutiques et elles se manifestent souvent sous forme épidémique. L'apparition de ce type d'épidémie dans certains services hospitaliers peut constituer un événement extrêmement grave qui pose de sérieux problèmes prophylactiques et thérapeutiques.

Staphylococcus aureus ist ein gram-positives kugelförmiges Bakterium. Es entwickelt sich zwischen 10°C und 45°C, die optimalen Temperaturverhältnisse liegen zwischen 30°C und 37°C. Der pH-Wert liegt zwischen 4 und 9, optimal zwischen 7 und 7,5. Obwohl sie nicht sporogen sind, sind Staphylokokken unter ungünstigen Umgebungsverhältnissen besonders resistent. Das Bakterium ist generell im Wasser, auf der Haut und in den Schleimhäuten zu finden.

Im menschlichen Organismus kann das Bakterium Infektionen verschiedener Art verursachen. In Krankenhausbereichen durch Staphylococcus aureus zugezogene Infektionen werden normalerweise von Stammzellen verursacht, die gegen verschiedene Chemotherapien resistent sind, und offenbaren sich häufig in epidemischer Form. Das Auftreten solcher Epidemien in bestimmten Abteilungen kann besonders schlimm sein und schwere prophylaktische und therapeutische Probleme hervorrufen.

ESCHERICHIA COLI

Escherichia coli è una specie che fa parte della famiglia delle Enterobacteriaceae, microrganismi Gram negativi ubiquitari che si trovano nel suolo, nell'acqua, nella vegetazione e fanno parte della flora intestinale della maggior parte degli animali compreso l'uomo. La sua coltura è molto facile con una grande tolleranza di variazione del pH, con un optimum di 7,5. La temperatura ottimale è 37°C. Resiste bene al calore: incubato a 45°C. L'Escherichia coli è un ospite normale dell'organismo umano in cui rappresenta la specie predominante della comunità batterica facoltativa residente nell'intestino crasso; per questo motivo la sua presenza in un dato materiale (ad es. acqua) può essere considerata un indizio sicuro di una contaminazione fecale.

Escherichia coli is a species of the family Enterobacteriaceae, ubiquitous Gram-negative micro-organisms that can be found in soil, water, vegetation and live in the gut flora of most animals, including humans.

Cultures of Escherichia coli are very easy to make, as they tolerate a wide range of pH, with optimum pH being 7.5. Optimum temperature is 37°C. They resist quite well to incubated heat at 45°C Escherichia coli is a normal host of human organism, in which it is the prevalent species of the facultative bacterial community living in the large intestine; that's why finding it in a given material (e.g. water) may be regarded as certain evidence of faecal contamination.

L'Escherichia coli, bacille appartenant à la famille des Enterobacteriaceae, est un microorganisme ubiquitaire à Gram négatif. On le trouve dans l'eau, le sol et la végétation, et il fait partie de la flore intestinale de la plupart des animaux, y compris de l'être humain. Sa culture est très facile avec une grande tolérance de variation de pH, le pH optimal étant 7,5. Sa température optimale est de 37 °C. Incubé à 45 °C, ce bacille résiste à la chaleur. L'Escherichia coli est une bactérie commensale prédominante de la flore aérobie facultative du gros intestin ; pour cette raison, sa présence dans un milieu donné (l'eau, par exemple) est un indice sûr de contamination fécale.

Escherichia coli ist eine Spezies, die zur Familie der Enterobacteriaceae gehört, ubiquitäre gram-negative Mikroorganismen, die sich im Erdreich, im Wasser und in der Vegetation befinden und zur Darmflora der meisten Tiere und auch der Menschen gehören. Die Fortpflanzung erfolgt sehr leicht, mit großer pH-Variationstoleranz, optimal mit einem pH-Wert von 7,5. Die optimale Temperatur liegt bei 37°C. Das Bakterium ist sehr

wärmebeständig: Inkubation bei 45°C. Das Escherichia coli ist ein üblicher Gast des menschlichen Organismus, wo es die dominierende Species der im Dickdarm residenten fakultativen Bakteriengemeinschaft darstellt; deshalb ist seine Anwesenheit in einem bestimmten Material (z.B. Wasser) ein sicherer Hinweis auf eine fäkale Kontamination.

PSEUDOMONAS AERUGINOSA

Pseudomonas aeruginosa è un batterio Gram negativo, capace di crescere a temperature comprese fra un minimo di 4°C e di un massimo di 42°C, ma non di svilupparsi al di sotto di pH 4.5. È un microorganismo molto presente nelle acque, nel suolo e come commensale sulla cute e nell'intestino. La sua scarsa o nulla sensibilità ai più comuni antibiotici fa sì che il suo sviluppo venga favorito da un qualsiasi trattamento con medicamenti antibatterici: l'azione dell'antibiotico, infatti, riducendo la concorrenza della restante popolazione microbica, permette al batterio di raggiungere consistenze numeriche altrimenti impossibili.

Pseudomonas aeruginosa is a Gram-negative bacterium, which can grow at a temperature of 4°C up to 42°C, but will not develop if pH is less than 4.5. It is a micro-organism that can be often found in water, soil and as a commensal on skin or guts. Because of its poor or no sensitivity to the most common antibiotics, its growth is boosted by any antibacterial drug: actually, by reducing the competition of the rest of the microbial population, the effect of the antibiotic

enables the bacterium to grow in numbers that would otherwise be impossible.

Pseudomonas aeruginosa est une bactérie à Gram négatif, capable de se développer à une température comprise entre un minimum de 4 °C et un maximum de 42 °C, mais incapable de se développer à un pH inférieur à 4.5. Surtout présent dans l'eau et le sol, ce microorganisme est une bactérie commensale de la peau et de l'intestin. Sa sensibilité, faible ou quasi nulle, aux antibiotiques les plus courants, fait que son développement est favorisé par de nombreux traitements à base de traitements antibactériens : en effet, l'action de l'antibiotique, en réduisant la concurrence de la population microbienne restante, permet à la bactérie d'atteindre une consistance numérique qui serait sinon impossible.

Pseudomonas aeruginosa ist ein gram-negatives Bakterium, das bei Temperaturen zwischen mindestens 4°C und maximal 42°C wachsen kann, sich bei pH-Werten unter 4.5 jedoch nicht entwickelt. Dieser Mikroorganismus ist stark vertreten in Gewässern, im Erdboden und als Kommensale auf der Haut und im Darm. Durch seine geringe oder fehlende Empfindlichkeit gegenüber den herkömmlichen Antibiotika wird seine Entwicklung bei irgendwelchen Behandlungen mit antibakteriellen Medikamenten gefördert: Die Wirkung des Antibiotikums erlaubt es dem Bakterium durch die Reduzierung der Konkurrenz der restlichen mikrobiellen Population tatsächlich, eine sonst nicht mögliche numerische Konsistenz zu erreichen.

ENTEROCOCCUS FAECALIS

Gli enterococchi sono batteri Gram positivi molto diffusi in natura. Fanno parte della normale flora microbica intestinale dell'uomo e degli animali, ma si ritrovano anche nelle piante e negli insetti.

Sono utilizzati come indicatori di contaminazione fecale nell'acqua e negli alimenti. Crescono a 10-45°C, in soluzione contenente fino al 6,5% di cloruro di sodio, a pH 9,6 e sopravvivono ad una temperatura di 60°C per 30 minuti.

Gli enterococchi sono batteri dotati di un basso potere patogeno ma possiedono geni che codificano la resistenza ad alcuni antibiotici, riescono perciò a sopravvivere negli ambienti in cui questi sono ampiamente utilizzati. Negli ultimi 15 anni, infatti, si sono rivelati spesso causa d'infezioni ospedaliere.

Enterococci are Gram-positive bacteria that are very widespread in nature. They belong to the normal microbial flora of humans and animals, but can also be found in plants and insects. They are used as indicators of faecal contamination of food and water. They grow at 10-45°C, in a solution containing up to 6.5% sodium chloride, with pH 9.6, and can survive at 60°C for 30 minutes.

Enterococci are poorly-pathogenic bacteria, but they have genes that encode some antibiotic-resistance, so they can survive in environments in which antibiotics are widely used. Actually, over the last 15 years, they have often caused hospital-acquired infections.

Les entérocoques, bactéries à Gram positif, sont très répandus dans la nature. Ils font partie de la flore microbienne intestinale de l'homme et des animaux, et on les trouve aussi dans les plantes et les insectes. Ils sont utilisés comme indicateurs de contamination fécale de l'eau et des aliments. Ils prolifèrent entre 10 °C et 45 °C, dans une solution contenant jusqu'à 6,5% de chlorure de sodium à pH 9.6, et survivent pendant 30 minutes à une température de 60 °C. Les entérocoques sont des bactéries à faible pouvoir pathogène, mais dont les gènes codifient la résistance à certains antibiotiques, ce qui leur permet de survivre dans les milieux où ceux-ci sont amplement utilisés. Au cours des 15 dernières années, les entérocoques ont en effet souvent été responsables d'infections en milieu hospitalier.

Enterokokken sind Gram-positive Bakterien, die in der Natur stark verbreitet sind. Sie gehören zur mikrobiellen Darmflora der Menschen und Tiere, sind aber auch in Pflanzen und Insekten zu finden. Sie werden als Anzeiger fäkaler Kontaminationen im Wasser und in Nahrungsmitteln verwendet. Sie wachsen bei 10-45°C, in Lösungen mit bis zu 6,5% Natriumchlorid, mit pH 9,6 und überleben 30 Minuten lang einer Temperatur von 60°C. Enterokokken sind Bakterien mit einem niedrigen pathogenen Vermögen, sie besitzen jedoch Gene, welche die Widerstandsfähigkeit gegenüber einiger Antibiotika codieren und deshalb in Bereichen überleben, in denen diese im breiteren Umfang verwendet werden. In den letzten 15 Jahren haben sie sich in der Tat in Krankenhausbereichen oft als Infektionsursache erwiesen.



unicolore bios bianco avorio cm 30x60 - 11³/₄"x23⁵/₈"



Premi e riconoscimenti
Awards and acknowledgements
Prix et Récompenses
Preise und Auszeichnungen

Bios Antibacterial® - Bios Self-Cleaning®

Hanno ricevuto i seguenti riconoscimenti internazionali
Have received the following International acknowledgements
Ont reçu les récompenses internationales suivantes:
Haben folgende internationale Auszeichnungen



2015

**A+Award Popular Choice Winner
Categories | Building Products:
Façades**

BIOS SELF-CLEANING®



2010

Selezionata per l'ADI Design Index

BIOS ANTIBACTERIAL CERAMICS®



2010

**AIT Innovation Award
"Architecture and Building", Essen
AIT e xia IntelligenteArchitektur**

BIOS ANTIBACTERIAL CERAMICS®



2010

**AIT Innovation Award
"Architecture and Flooring",
Hannover
AIT e xia IntelligenteArchitektur**

BIOS ANTIBACTERIAL CERAMICS®



2011

**Produkt des Jahres
Fliesen&Platten Leserwahl**

BIOS ANTIBACTERIAL CERAMICS®



2013

Iconic Awards

BIOS ANTIBACTERIAL CERAMICS®
BIOS SELF-CLEANING®

Certificazioni Certifications Zertifizierungen

Le prestazioni di **Bios Antibacterial®** sono state verificate e certificate dal Dipartimento di scienze biomediche, sezione di microbiologia, dell'Università di Modena e Reggio Emilia.

The properties of **Bios Antibacterial®** have been tested and certified by the Department of Biomedical Science, Microbiology Section, of the University of Modena and Reggio Emilia.

Les performances de **Bios Antibacterial®** ont été contrôlées et certifiées par la Division de microbiologie du Département de sciences biomédicales de l'Université de Modène et Reggio d'Émilie.

Die Leistungen von **Bios Antibacterial®** wurden vom Departement für biomedizinische Wissenschaften Abteilung Mikrobiologie der Universität Modena und Reggio Emilia geprüft und zertifiziert.

 Test method: ISO 27447:2009 Test method for anti-bacterial activity of semiconducting photocatalytic materials Test method: film adhesion			
Material product sample	Date of receipt: 03/05/2017 Ceramic materials Hydroxyapatite anti-bacterial tile Test information: Test requested by CatalpaTrade Palace S.p.A. Treated specimens: 50x50mm Non-treated glass: 50x50 mm All specimens disinfectant prior to testing by ethanol UV intensity (0.001mW/cm2) time exposure : 3h, Temperature 23°C Test bacteria <i>Staphylococcus aureus</i> ATCC 6538 and <i>Escherichia coli</i> ATCC 8739		
TEST	METHOD	UM	RESULT
Antibacterial Photocatalytic materials, <i>Escherichia coli</i> ATCC 8739	ISO 27447:2009 film adhesion		
N° bacteria inoculated		Cells/ml	2400.000
A average number of bacteria non-treated specimens after inoculation		Cells/ml	250.000
BL- Average number of bacteria non-treated specimens after UV irradiation (0.001mW)		Cells/ml	230.000
CL- average photocatalytic antibacterial activity after UV irradiation (0.001mW)		Cells/ml	8
RL- photocatalytic antibacterial activity after UV irradiation (0.001mW)		Log10	4.4
Reduction of bacteria from non treated specimens after UV irradiation (0.001mW)		%	99.9
Antibacterial Photocatalytic materials, <i>E. coli</i> ATCC 8739	ISO 27447:2009 film adhesion		
N° bacteria inoculated		Cells/ml	240.000
A average number of bacteria non-treated specimens after inoculation		Cells/ml	230.000
BL- Average number of bacteria non-treated specimens after UV irradiation (0.001mW)		Cells/ml	200.000
CL- average photocatalytic antibacterial activity after UV irradiation (0.001mW)		Cells/ml	10
RL- photocatalytic antibacterial activity after UV irradiation (0.001mW)		Log10	4.3
Reduction of bacteria from non treated specimens after UV irradiation (0.001mW)		%	99.9

Scientific advisor
Dott.ssa Carla Sabia
Carla Sabia

 Test method: ISO 27447:2009 Test method for anti-bacterial activity of semiconducting photocatalytic materials Test method: film adhesion			
Material product sample	Date of receipt: 16/05/2017 Ceramic materials Hydroxyapatite anti-bacterial tile Test information: Test requested by CatalpaTrade Palace S.p.A. Treated specimens: 50x50mm Non-treated glass: 50x50 mm All specimens disinfectant prior to testing by ethanol UV intensity (0.001mW/cm2) time exposure : 3h, Temperature 23°C Test bacteria <i>Paralomonas aeruginosa</i> ATCC 27851 and <i>Enterococcus faecalis</i> ATCC strc 29212		
TEST	METHOD	UM	RESULT
Antibacterial Photocatalytic materials, <i>Paralomonas aeruginosa</i> ATCC 27851	ISO 27447:2009 film adhesion		
N° bacteria inoculated		Cells/ml	2500.000
A average number of bacteria non-treated specimens after inoculation		Cells/ml	250.000
BL- Average number of bacteria non-treated specimens after UV irradiation (0.001mW)		Cells/ml	230.000
CL- average photocatalytic antibacterial activity after UV irradiation (0.001mW)		Cells/ml	30
RL- photocatalytic antibacterial activity after UV irradiation (0.001mW)		Log10	4.3
Reduction of bacteria from non treated specimens after UV irradiation (0.001mW)		%	99.9
Antibacterial Photocatalytic materials, <i>Enterococcus faecalis</i> ATCC strc 29212	ISO 27447:2009 film adhesion		
N° bacteria inoculated		Cells/ml	2500.000
A average number of bacteria non-treated specimens after inoculation		Cells/ml	250.000
BL- Average number of bacteria non-treated specimens after UV irradiation (0.001mW)		Cells/ml	230.000
CL- average photocatalytic antibacterial activity after UV irradiation (0.001mW)		Cells/ml	10
RL- photocatalytic antibacterial activity after UV irradiation (0.001mW)		Log10	4.3
Reduction of bacteria from non treated specimens after UV irradiation (0.001mW)		%	99.9

Scientific advisor
Dott.ssa Carla Sabia
Carla Sabia

bios. ceramics®



Università degli Studi di Modena e Reggio Emilia
 Dipartimento di Scienze Biomediche
 Sezione di Microbiologia

1 In data 28/03/2007 si è ricevuto da Casalgrande Padana spa il campione siglato:

Campione 4 – Bianco A Tab 30x60
 Tono AA - Calibro 5
 Produzione 26/03/2007

2 Materiale fornito per la costruzione del

**"CENTRO DI MEDICINA RIGENERATIVA"
di Modena**

3 È stata saggiata l'attività antibatterica, espressa in percentuale di abbattimento della carica microbica, del campione nei confronti di:

<i>Staphylococcus aureus</i>	ATCC	6538
<i>Enterococcus faecalis</i>	ATCC	29212
<i>Escherichia coli</i>	ATCC	25922
<i>Pseudomonas aeruginosa</i>	ATCC	27859

4 L'attività antibatterica del campione è risultata essere del **99.9%** nei confronti dei germi testati.

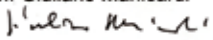
RESPONSABILE SCIENTIFICO
 Prof. Giuliano Manicardi

Via G. Campi 287, 41100 Modena, Italy-
 Tel.: ++39 59-2055469, 2055795- Fax. 059-2055483-Email: segrdsd@unimo.it

1. On March 28, 2007 Casalgrande Padana spa sent us the following sample:

2. This is one of the materials used for the building of the

3. We have analysed the antibacterial activity of the sample. It is expressed in terms of percent of abatement of the microbial load of the sample. We analysed the following:

4. The sample's antibacterial activity turned out to be 99.9% based on the germs we tested.

1. Le 28 mars 2007 la société Casalgrande Padana spa nous a fait parvenir l'échantillon suivant :

2. Il s'agit d'un des matériaux utilisés pour la réalisation du

3. Nous avons analysé l'activité antibactérienne de l'échantillon, exprimée en pourcentage de réduction de la charge microbienne de l'échantillon. Nous avons analysé les éléments suivants :

4. L'activité antibactérienne de l'échantillon, considérant les germes ayant fait l'objet de notre essai, est de 99,9%.

1. Am 28. März 2007 haben wir eine Stichprobe von Casalgrande Padana spa erhalten die folgendermaßen gekennzeichnet war:

2. Das Material dient dem Bau des

3. Es wurde die antibakterielle Wirksamkeit getestet, unter der prozentualen Angabe der antibakteriellen Reduktion des Musters, in Bezug auf:

4. Die antibakterielle Wirksamkeit des Musters in Bezug auf die getesteten Bakterien betrug 99,9%.

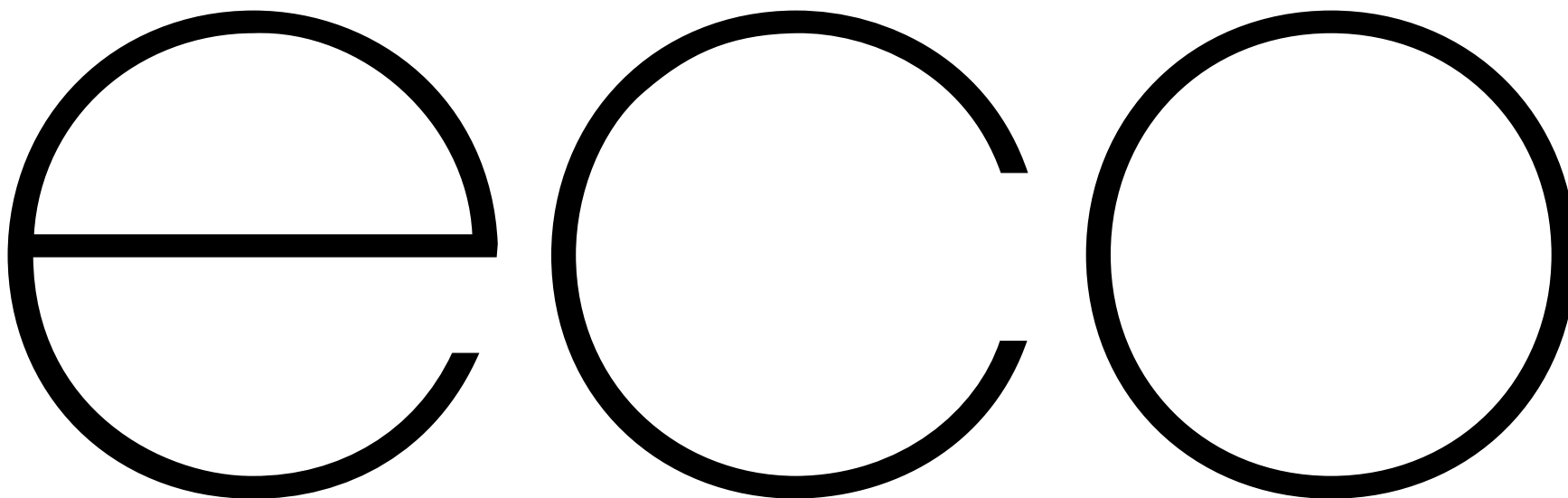

ECOSOSTENIBILITÀ

come filosofia di riferimento per realizzare prodotti ceramici evoluti, in grado di rispondere alla domanda più qualificata proveniente dal settore dell'architettura. Elementi in grès porcellanato prodotti da Casalgrande Padana attraverso un processo virtuoso e attento alla tutela dell'ambiente, capaci di coniugare libertà e flessibilità creativa con i più elevati contenuti tecnologici e prestazionali.

ECO-SUSTAINABILITY

as a reference philosophy for creating evolved ceramic products able to satisfy the most qualified demands from the sphere of architecture. Porcelain stoneware tiles produced by Casalgrande Padana through a virtuous process with safeguarding the environment as a prime concern, products that combine versatility and boundless scope for creativeness with the highest technological and performance specifications.

ÉCO-DURABILITÉ

comme philosophie de référence pour réaliser des produits céramiques évolués, en mesure de satisfaire la demande la plus qualifiée, provenant du secteur de l'architecture. Éléments en grès cérame produits par Casalgrande Padana à travers un procédé respectueux et soucieux de l'environnement, capables d'allier liberté et flexibilité créative aux plus hauts contenus technologiques et de performances.

ÖKO-NACHHALTIGKEIT

als Bezugsphilosophie, um ausgereifte Keramikprodukte zu realisieren, die in der Lage sind, der qualifiziertesten Nachfrage gerecht zu werden, die aus dem Sektor der Architektur kommt. Elemente aus Feinsteinzeug, von Casalgrande Padana durch einen virtuoson und auf den Umweltschutz achtenden Prozess hergestellt, die in der Lage sind, kreative Freiheit und Flexibilität mit den höchsten technologischen und leistungsmäßigen Eigenschaften zu verbinden.



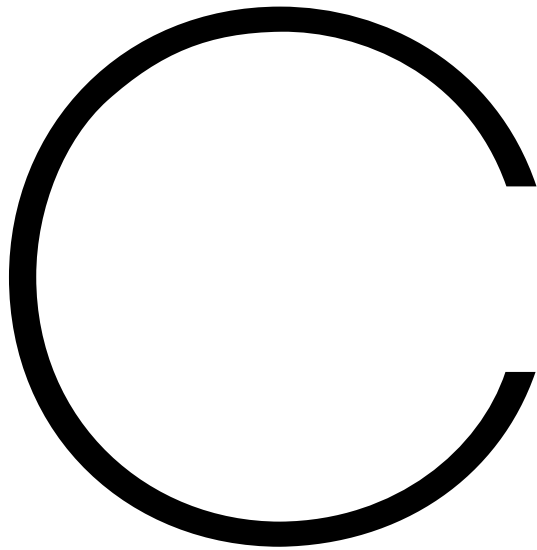
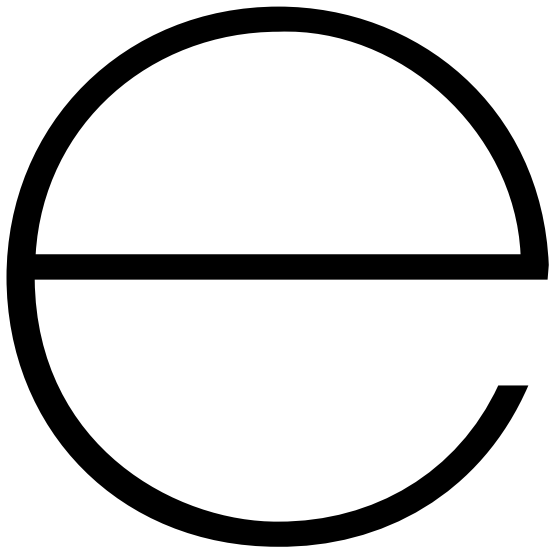

eco**stone** éco**pierre** öko**stein**

pietra

ecopietra

- 42 **pietre di paragone**
- 50 **amazzoneia**
- 56 **chalon**
- 62 **limestone**
- 68 **meteor**
- 76 **mineral chrom**
- 82 **pietra baugé**
- 88 **pietre di sardegna**
- 96 **stonewash**
- 102 **terre toscane**
- 110 **pietre etrusche**
- 118 **basaltina**
- 128 **pietra blue**
- 132 **pietra piacentina**
- 136 **kerblock**
- 140 **natural slate**
- 144 **pietre runiche**
- 148 **titano**
- 154 **ardesia**
- 158 **lavagna**
- 162 **patio**
- 166 **agorà**
- 170 **rocks**
- 174 **palatino**

**PIETRA**

Roccia da costruzione o decorazione. La composizione mineralogica molto varia di questo gruppo di materiali viene classificata in due grandi categorie: Rocce tenere o poco compatte, tra le quali le sedimentarie [calcareni, arenarie a cemento calcareo ecc.] e le piroclastiche come i tufi e i peperini; Rocce dure o compatte, tra le quali le pietre a spacco naturale [quarziti, micascisti, gneiss, lastroidi, ardesie ecc.] e alcune vulcaniti, come i basalti, le trachiti e i leuciti.

STONE

Rock used for building or decorating purposes. The extremely varied mineralogical composition of this group of materials is divided into two large categories: Soft rocks or not very compact, including sedimentary rock [calcarenes, limy cement type sandstones, etc.] and pyroclastic materials like tuffs and peperino rocks; Hard rocks or compact ones, such as naturally split stones [quarzites, mica schists, gneiss, slab-structured rocks, slates, etc.] and certain volcanites, such as basalts, trachytes and leukocytes.

pietre di paragone grigio aitos

pietre di paragone

PIETRE NATIVE



grigio aitos cm 90x180 - 35³/₈"x70⁷/₈"

COLORI COLOURS COULEURS FARBEN

onsernone

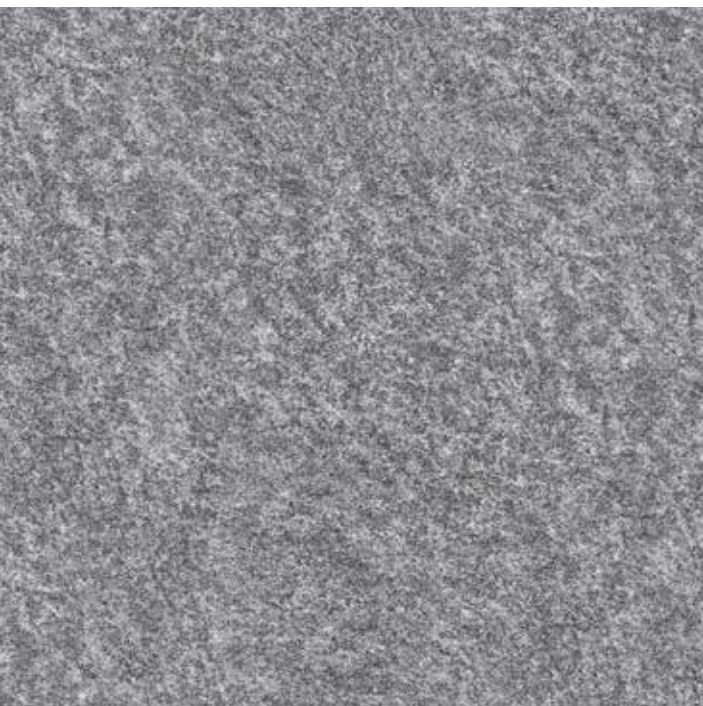

gré



gré bianco

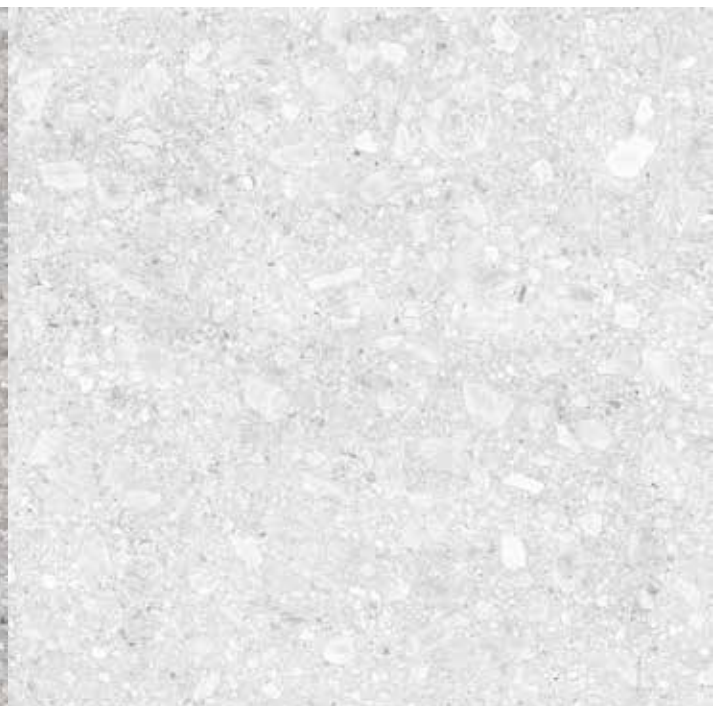

pietra del cardoso



black pearl



grigio tao

pietre di paragone

PIETRE NATIVE

gré nero

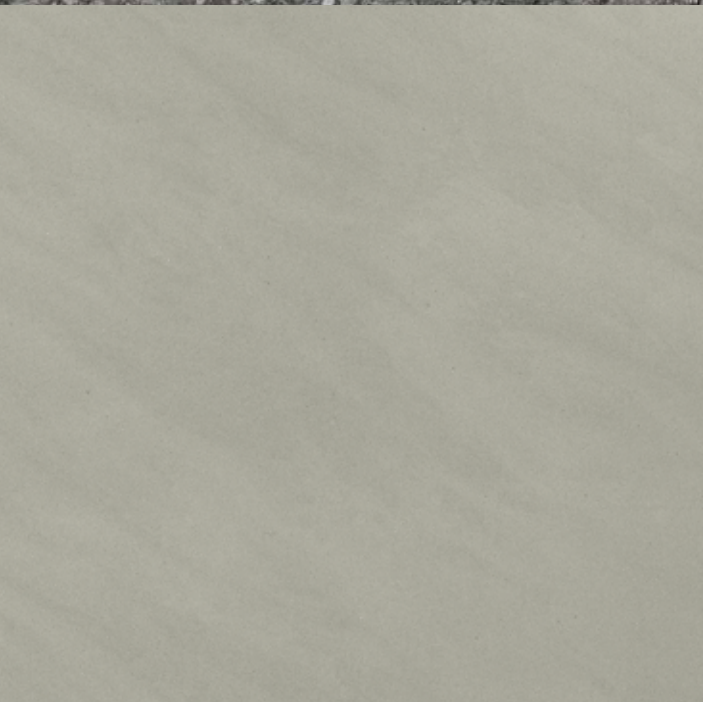

grigio aitos



onsernone *grip*
cm 60x120 - 23⁵/₈"x47¹/₄"

COLORI COLOURS COULEURS FARBEN

pietra piacentina new

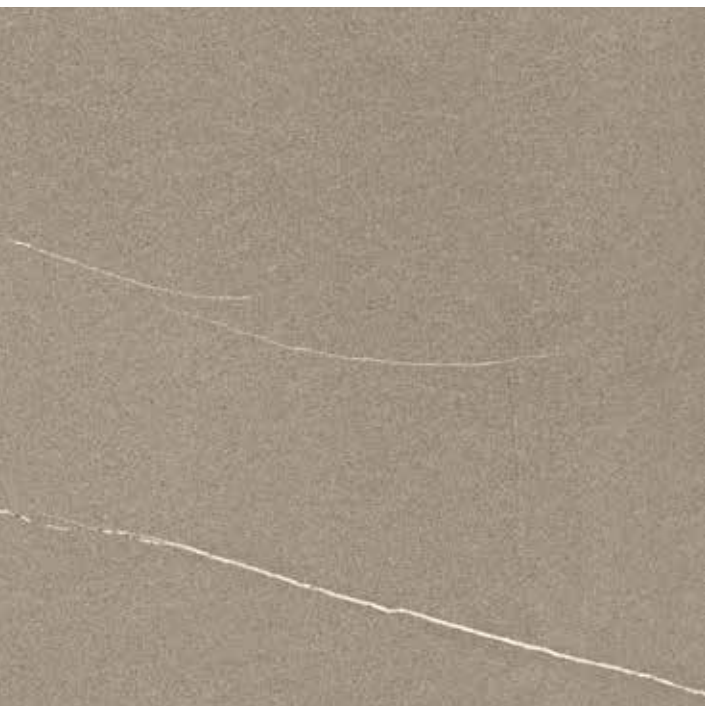

vals



jura grigia



jura beige



pietra di vicenza



luni

SUPERFICI SURFACES SURFACES OBERFLÄCHEN

pietre di paragone

PIETRE NATIVE

lappata

naturale matt naturelle matt R10

grip R12

FORMATI SIZES FORMATS FORMATE

Formati Sizes Formats Formate	cm 30x60 11 ³ / ₄ "x23 ⁵ / ₈ "	cm 60x60 23 ⁵ / ₈ "x23 ⁵ / ₈ "	cm 60x120 23 ⁵ / ₈ "x47 ¹ / ₄ "	cm 45x90 17 ³ / ₄ "x35 ³ / ₈ "	cm 90x90 35 ³ / ₈ "x35 ³ / ₈ "	cm 90x180 35 ³ / ₈ "x70 ⁷ / ₈ "
Black Pearl	●	●	●	●	●	●
Pietra Plasentina New	● ●	● ●	● ● *	● ● *	● ● *	● ● *
Pietra del Cardoso	● ●	● ●	● ● *	● ● *	● ● *	● ● *
Onsernone	● ●	● ●	● ● *	● ● *	● ● *	● ● *
Vals	● ●	● ●	● ● *	● ● *	● ● *	● ● *
Grigio Aitos	● ●	● ●	● ● *	● ● *	● ● *	● ● *
Grigio Tao	● ●	● ●	● ● *	● ● *	● ● *	● ● *
Jura Grigia	● ● ●	● ● ●	● ● *	● ● *	● ● *	● ● *
Jura Beige	● ● ●	● ● ●	● ● *	● ● *	● ● *	● ● *
Gré	● ●	● ●	● ● *	● ● *	● ● *	● ● *
Gré Nero	● ●	● ●	● ● *	● ● *	● ● *	● ● *
Gré Bianco	● ●	● ●	● ● *	● ● *	● ● *	● ● *
Pietra di Vicenza	● ●	● ●	● ● *	● ● *	● ● *	● ● *
Luni	● ●	● ●	● ● *	● ● *	● ● *	● ● *
Spessori* Thicknesses* Epaisseurs* Stärken*	mm 10 mm 9	mm 10	mm 10	mm 10	mm 10	mm 10

● Naturale Matt Naturelle Matt **R10** (Ad eccezione di Except for À l'exception de Mit Ausnahme von: **Black Pearl**)

● Grip **R12**

● Lappata

* Grip su richiesta Grip on request Grip sur demande Grip Auf Anfrage können



Accentuata
Accentuated
Forte
Akzentuiert

Caratteristiche tecniche e imballi a pagina

Technical features and packing on page

Caractéristiques techniques et emballages à la page

Technische Eigenschaften und Verpackungen auf Seite

448

PEZZI SPECIALI TRIMS ACCESSOIRES FORMSTÜCKE

Battiscopa Bullnose
Plinthe à bord arrondi Stehsockel

cm 9x60 - 3¹/₂"x23⁵/₈"

cm 9x90 - 3¹/₂"x35³/₈"

●



Gradone (assemblato)

cm 120x33 - 47¹/₄"x13"

● ● **

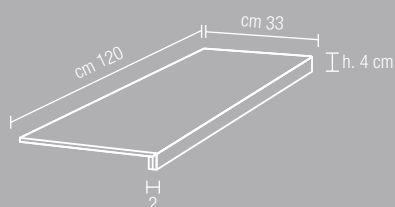

** Ad eccezione di Except for À l'exception de Mit Ausnahme von: **Black Pearl**

Gradino Step tread
Nez de marche Stufenplatte

cm 30x60 - 11³/₄"x23⁵/₈"

● ● **



Angolare (assemblato)

cm 120x33 - 47¹/₄"x13"

● ● **

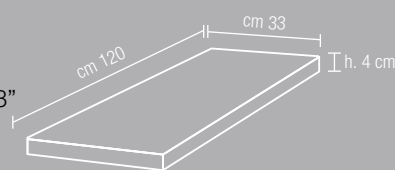

DECORI DECORS DÉCORS DEKORE

pietre di paragone

PIETRE NATIVE

mosaico 6x6*

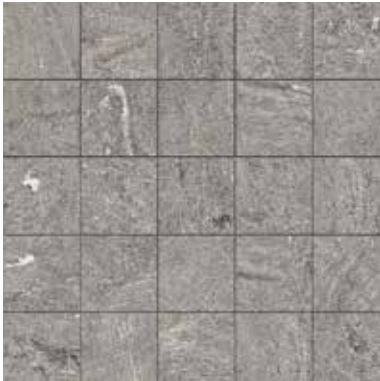

cm 30x30 - 11³/₄"x11³/₄"
 tessera cm 6x6 - 2³/₈"x2³/₈"
su rete on net sur trame auf Netz

mosaico 10x10*



cm 30x30 - 11³/₄"x11³/₄"
 tessera cm 10x10 - 4"x4"
su rete on net sur trame auf Netz

* Disponibile in tutti i colori della serie, superficie naturale e grip.
 Available in all the colours of the series, matt and grip surface.
 Disponible dans toutes les couleurs de la série, surface naturelle et grip.
 Verfügbar in allen Farben, matte und grip Oberfläche.

**vals** cm 60x60 - 23⁵/₈"x23⁵/₈"

amazonia dragon black

amazzonia
PIETRE NATIVE



dragon black cm 45x90 - 17³/₄"x35³/₈"

COLORI COLOURS COULEURS FARBEN

dragon black



dragon green



dragon grey

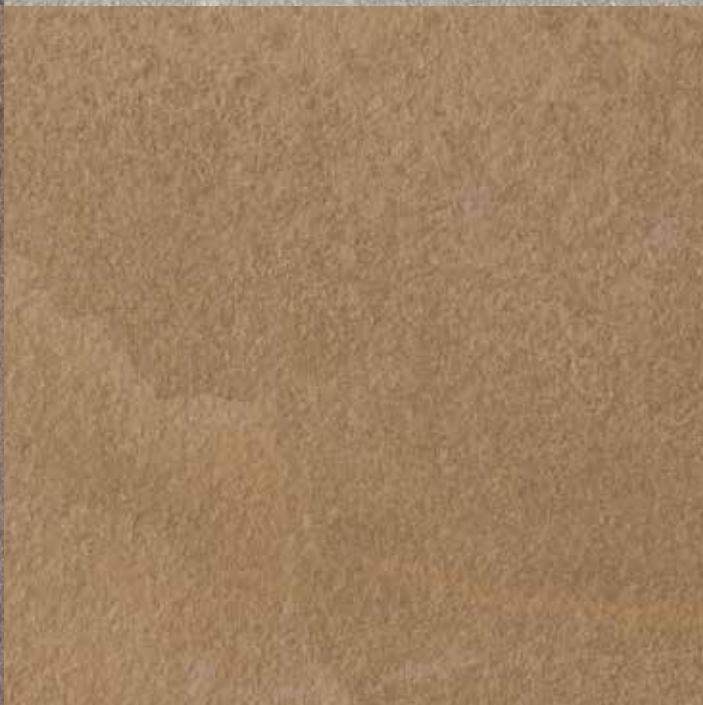

dragon chocolate

dragon brown

eldorado

SUPERFICI SURFACES
SURFACES OBERFLÄCHEN

amazzonia
PIETRE NATIVE

dragon white









naturale matt naturelle matt R10A



dragon beige

grip R12 A+B+C

FORMATI SIZES FORMATS FORMATE

Formati Sizes Formats Formate	 cm 30x30 11 ³ / ₄ "x11 ³ / ₄ "	 cm 45x45 17 ³ / ₄ "x17 ³ / ₄ "	 cm 30x60 11 ³ / ₄ "x23 ⁵ / ₈ "	 cm 60x60 23 ⁵ / ₈ "x23 ⁵ / ₈ "	 cm 45x90 17 ³ / ₄ "x35 ³ / ₈ "
Superfici Surfaces Surfaces Oberflächen	● ●	● ●	● ●	● ●	● ●
Spessori Thicknesses Épaisseurs Stärken	mm 9,4	mm 10,5	mm 10,5 mm 9,4 mm 9,4*	mm 10,5	mm 10,5 mm 20**
<ul style="list-style-type: none"> ● Naturale Matt Naturelle Matt R10 A ● Grip R12 A+B+C <p>Rettificate in un unico calibro. Single caliber, rectified version. Rectifiés en un unique calibre. Einem einzigen Werkmass maßgeschliffen geliefert.</p> <p>Nel caso di combinazioni di formati di spessori diversi, specificarlo espressamente nell'ordine. Please specify in your order if you wish to purchase formats including more than one thickness. Prière de spécifier dans votre commande si vous souhaitez acheter des formats avec différentes épaisseurs. Bitte weisen Sie im Bestellungsformular ausdrücklich darauf hin, wenn Sie Formatkombinationen mit verschiedenen Stärken wünschen.</p>	 <p>Accentuata Accentuated Forte Akzentuiert 448</p> <p>Caratteristiche tecniche e imballi a pagina Technical features and packing on page Caractéristiques techniques et emballages à la page Technische Eigenschaften und Verpackungen auf Seite</p>				
	<p>* Non rettificato. Unrectified. Non rectifié. Nicht kalibriert. ** Dragon Black, Dragon Grey, Dragon Beige, Dragon White, Dragon Brown Superficie grip. Grip surface. Surface grip. Grip Oberfläche.</p>				

PEZZI SPECIALI TRIMS ACCESSOIRES FORMSTÜCKE

Battiscopa Bullnose Plinthe à bord arrondi Stehsockel

cm 9x45 - 3¹/₂"x17³/₄"
cm 9x60 - 3¹/₂"x23⁵/₈"



Gradino Step tread Nez de marche Stufenplatte

cm 45x45 - 17³/₄"x17³/₄"
cm 30x60 - 11³/₄"x23⁵/₈"

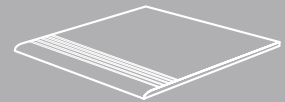

Gradone (assemblato)

cm 60x33 - 23⁵/₈"x13"

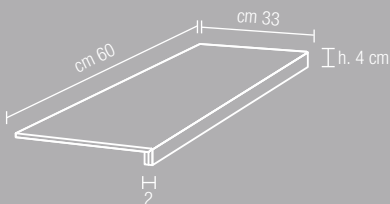

Angolare (assemblato)

cm 60x33 - 23⁵/₈"x13"

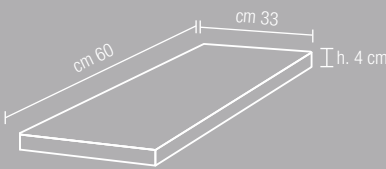

Terminale Pezzo unico pressato

Pièce unique pressée
Pressed single piece
Gepresstes Einzelstück
cm 15x30x4,5 - 5⁷/₈"x11³/₄"x1³/₄"

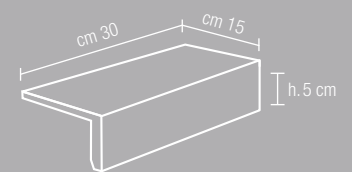

Art. 9610 Bordo

cm 33x90 - 11³/₄"x35³/₈"



Art. 9617 Bordo angolare esterno

cm 33x45 - 11³/₄"x17³/₄"

2pcs  45°



Art. 9618 Bordo angolare interno

cm 33x45 - 11³/₄"x17³/₄"

2pcs  45°



Art. 9630 Bordo

cm 22,5x90 - 8⁷/₈"x35³/₈"

Art. 9637 Bordo angolare esterno

cm 22,5x45 - 8⁷/₈"x17³/₄"

Art. 9638 Bordo angolare interno

cm 22,5x45 - 8⁷/₈"x17³/₄"

Art. 9883 Griglia

cm 30x40 - 11³/₄"x15³/₄"

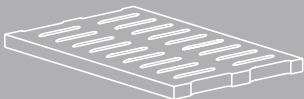

Art. 9885 Griglia

cm 13x40 - 5¹/₈"x15³/₄"



Art. 9884 Griglia angolare

cm 30x40 - 11³/₄"x15³/₄"

2pcs  45°



Art. 9886 Griglia angolare

cm 13x40 - 5¹/₈"x15³/₄"

2pcs  45°



DECORI DECORS DÉCORS DEKORE

amazzonia
 PIETRE NATIVE

mosaico 3x3*

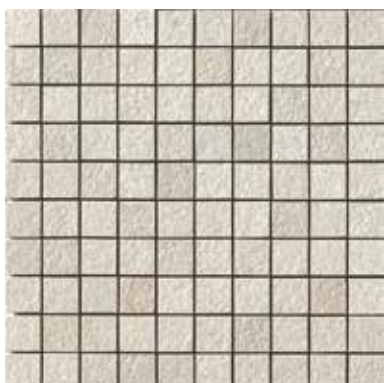

cm 30x30 - 11³/₄"x11³/₄"
 tessera cm 3x3 - 1¹/₈"x1¹/₈"
 su rete on net sur trame auf Netz

mosaico 6x6*



cm 30x30 - 11³/₄"x11³/₄"
 tessera cm 6x6 - 2³/₈"x2³/₈"
 su rete on net sur trame auf Netz

composizione A*

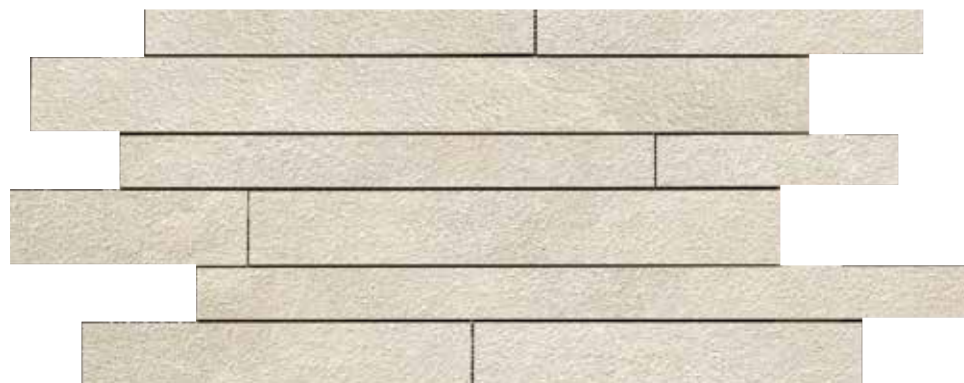

cm 30x60 - 11³/₄"x23⁵/₈"
 su rete on net sur trame auf Netz

* Disponibile in tutti i colori della serie su superficie naturale. A richiesta su superficie grip.
 Available in all the matt colours. On request also on grip surface.
 Disponible dans toutes les couleurs pour la surface naturelle. Sur demande la finition grip.
 Verfügbar in allen Farben der Serie, matte Oberfläche. Auf Anfrage grip Oberfläche.



composizione A eldorado cm 30x60 - 11³/₄"x23⁵/₈", **dragon beige grip** cm 30x60 - 11³/₄"x23⁵/₈"

chalon cream

chalon

PIETRE NATIVE



chalon cream cm 60x60 - 23⁵/₈"x23⁵/₈"

COLORI COLOURS COULEURS FARBEN

kaki



beige



grey



cream

SUPERFICI SURFACES SURFACES OBERFLÄCHEN











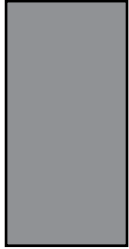

chalon
PIETRE NATIVE

lappata

naturale matt naturelle matt R10

grip R12

FORMATI SIZES FORMATS FORMATE

Formati Sizes Formats Formate			
	cm 30x60 11 ³ / ₄ "x23 ⁵ / ₈ "	cm 60x60 23 ⁵ / ₈ "x23 ⁵ / ₈ "	cm 60x120 23 ⁵ / ₈ "x47 ¹ / ₄ "
Superfici Surfaces Surfaces Oberflächen	  	  	  
Spessori Thicknesses Epaisseurs Stärken	mm 10 mm 9	mm 10	mm 10

- Naturale Matt Naturelle Matt **R10**
- Lappata
- Grip **R12**

Caratteristiche tecniche e imballi a pagina
 Technical features and packing on page
 Caractéristiques techniques et emballages à la page
 Technische Eigenschaften und Verpackungen auf Seite
448

PEZZI SPECIALI TRIMS ACCESSOIRES FORMSTÜCKE

Battiscopa Bullnose
Plinthe à bord arrondi Stehsockel
 cm 9x60 - 3¹/₂"x23⁵/₈"



Gradino Step tread
Nez de marche Stufenplatte
 cm 30x60 - 11³/₄"x23⁵/₈"

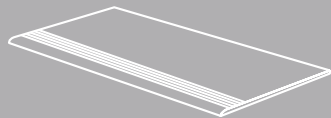

Gradone (assemblato)
 cm 120x33 - 47¹/₄"x13"

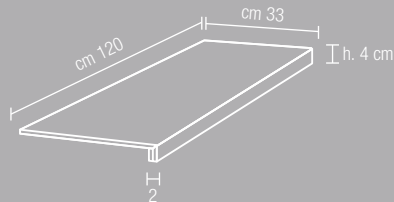

Angolare (assemblato)
 cm 60x33 - 23⁵/₈"x13"

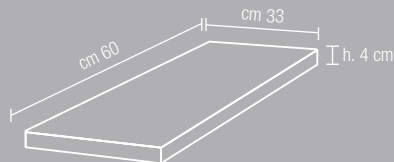

chalon beige cm 60x60 - 23⁵/₈"x23⁵/₈"

DECORI DECORS DÉCORS DEKORE

chalon
PIETRE NATIVE

mosaico 6x6*



cm 30x30 - 11³/₄"x11³/₄"
tessera cm 6x6 - 2³/₈"x2³/₈"
su rete on net sur trame auf Netz

mosaico 10x10*



cm 30x30 - 11³/₄"x11³/₄"
tessera cm 10x10 - 4"x4"
su rete on net sur trame auf Netz

* Disponibile in tutti i colori della serie su superficie naturale.
A richiesta su superficie grip e lappata.
Available in all the matt colours.
On request also on grip and lappata surface.
Disponibile dans toutes les couleurs pour la surface naturelle.
Sur demande la finition grip et lappata.
Verfügbar in allen Farben der Serie, matte Oberfläche.
Auf Anfrage grip und lappata Oberfläche.



chalon beige grip cm 30x60 - 11³/₄"x23⁵/₈"

limestone beige

limestone

PIETRE NATIVE



limestone beige cm 60x60 - 23⁵/₈"x23⁵/₈"

COLORI COLOURS COULEURS FARBEN

nero



grigio



beige





limestone

PIETRE NATIVE

limestone nero cm 60x60 - 23⁵/₈"x23⁵/₈"

FORMATI SIZES FORMATS FORMATE

Formati Sizes Formats Formate	 cm 30x60 11 ³ / ₄ "x23 ⁵ / ₈ "	 cm 60x60 23 ⁵ / ₈ "x23 ⁵ / ₈ "
Superfici Surfaces Surfaces Oberflächen	●	●
Spessori Thicknesses Epaisseurs Stärken	mm 10 mm 9	mm 10

- Naturale Matt Naturelle Matt **R10**



Accentuata
Accentuated
Forte
Akzentuiert

Caratteristiche tecniche e imballi a pagina
Technical features and packing on page
Caractéristiques techniques et emballages à la page
Technische Eigenschaften und Verpackungen auf Seite

448

PEZZI SPECIALI TRIMS ACCESSOIRES FORMSTÜCKE

Battiscopa Bullnose
Plinthe à bord arrondi Stehsockel
cm 9x60 - 3¹/₂"x23⁵/₈"



Gradino Step tread
Nez de marche Stufenplatte
cm 30x60 - 11³/₄"x23⁵/₈"

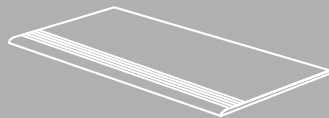

Gradone (assemblato)
cm 60x33 - 23⁵/₈"x13"

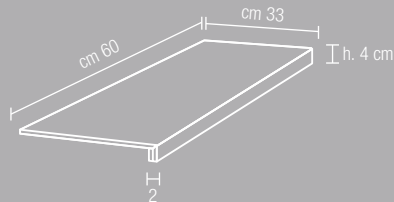

Angolare (assemblato)
cm 60x33 - 23⁵/₈"x13"

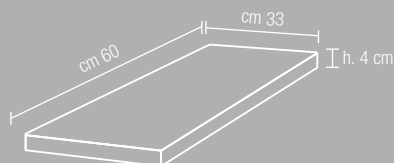

DECORI DECORS DÉCORS DEKORE

mosaico 6x6*



cm 30x30 - 11³/₄"x11³/₄"
tessera cm 6x6 - 2³/₈"x2³/₈"
su rete on net sur trame auf Netz

mosaico 10x10*



cm 30x30 - 11³/₄"x11³/₄"
tessera cm 10x10 - 4"x4"
su rete on net sur trame auf Netz

* Disponibile in tutti i colori della serie.
Available in all the colours of the series.
Disponibile dans tous les couleurs de la série.
Verfügbar in allen Farben.

limestone

PIETRE NATIVE



beige cm 60x60 - 23⁵/₈"x23⁵/₈"
mosaico 6x6 beige cm 30x30 - 11³/₄"x11³/₄"

meteor grigio

meteor
PIETRE NATIVE



grigio cm 30x30 - 11³/₄"x11³/₄"

COLORI COLOURS COULEURS FARBEN

grafite



nero

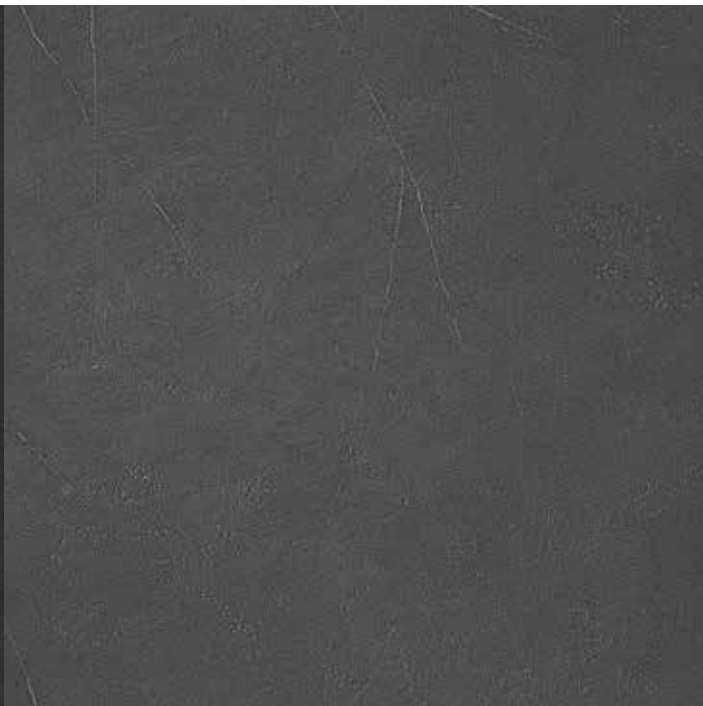

grigio



rosso



brown



noce

meteor
PIETRE NATIVE

perla

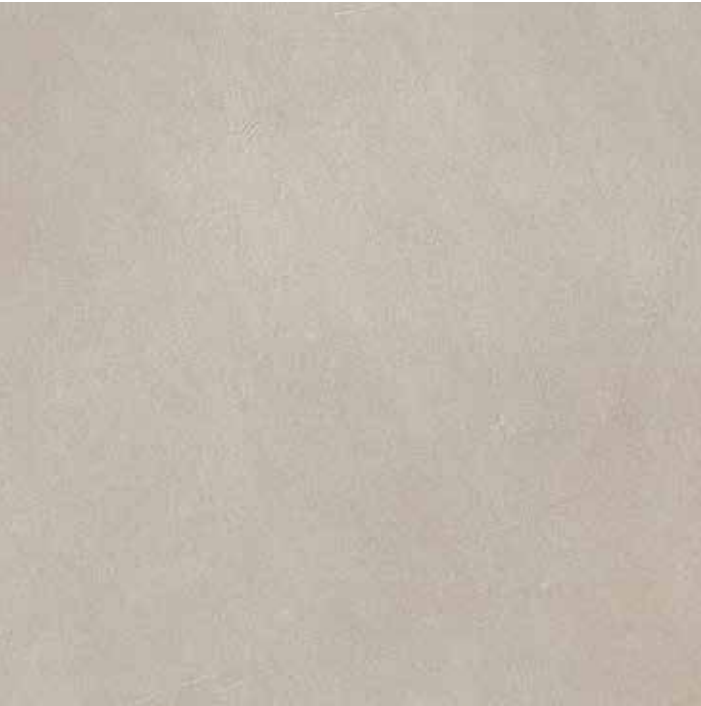

bianco



beige









almond

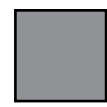

nero, grigio, perla
cm 60x60 - 23⁵/₈"x23⁵/₈"

FORMATI SIZES FORMATS FORMATE

Formati Sizes Formats Formate	 cm 15x15 5 ⁷ / ₈ "x5 ⁷ / ₈ "	 cm 30x30 11 ³ / ₄ "x11 ³ / ₄ "	 cm 40x40 15 ³ / ₄ "x15 ³ / ₄ "	 45x45 18"x18"	 cm 15x60 5 ⁷ / ₈ "x23 ⁵ / ₈ "	 cm 30x60 11 ³ / ₄ "x23 ⁵ / ₈ "	 cm 60x60 23 ⁵ / ₈ "x23 ⁵ / ₈ "
Superfici Surfaces Surfaces Oberflächen	●	●●	●●	●●	●	●●	●●
Spessori Thicknesses Épaisseurs Stärken	mm 9,4	mm 9,4 mm 8,2*	mm 9	mm 9*	mm 9,4	mm 10,5 mm 9,4 mm 9,4*	mm 10,5

- Naturale Matt Naturelle Matt **R10**
- Lappata



Media
Medium
Moyenne
Mittel

Caratteristiche tecniche e imballi a pagina
Technical features and packing on page
Caractéristiques techniques et emballages à la page
Technische Eigenschaften und Verpackungen auf Seite
448

Rettificata in un unico calibro. Single caliber, rectified version.
Rectifiés en un unique calibre. Einem einzigen Werkmass maßgeschliffen geliefert.

Nel caso di combinazioni di formati di spessori diversi, specificarlo espressamente nell'ordine.
Please specify in your order if you wish to purchase formats including more than one thickness.
Prière de spécifier dans votre commande si vous souhaitez acheter des formats avec différentes épaisseurs.
Bitte weisen Sie im Bestellungsformular ausdrücklich darauf hin, wenn Sie Formatkombinationen mit verschiedenen Stärken wünschen.

* Solo naturale, versione non rettificata e solo nei colori:
Only matt, not rectified version and only in the colours:
Seulement naturel, version non rectifiée et seulement dans les couleurs :
Nur matt, in der nicht rektifizierte Version und in die Farben:
Nero, Grigio, Noce, Beige, Almond, Bianco

PEZZI SPECIALI TRIMS ACCESSOIRES FORMSTÜCKE

Battiscopa Bullnose
Plinthe à bord arrondi Stehsockel
cm 9x30 - 3¹/₂"x11³/₄"
cm 9x45 - 3¹/₂"x17³/₄" **
cm 9x60 - 3¹/₂"x23⁵/₈"



Gradino Step tread
Nez de marche Stufenplatte
cm 30x30 - 11³/₄"x11³/₄"
cm 40x40 - 15³/₄"x15³/₄"
cm 30x60 - 11³/₄"x23⁵/₈"

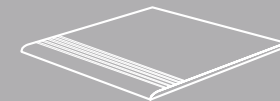

Tozzetto Insert
Cabochon Einleger
cm 9x9 - 3¹/₂"x 3¹/₂"



Listello Listel
Listel Zeilerleiste
cm 9x30 - 3¹/₂"x11³/₄"



Terminale Pezzo incollato
Glued piece
Pièce collee
Geklebter Stück
cm 15x30x5 - 5⁷/₈"x11³/₄"x2"

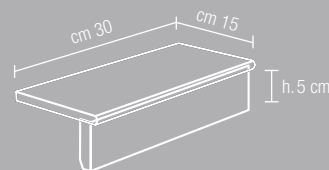

Scalino e scalino angolare
cm 30x33 - 11³/₄"x 13"

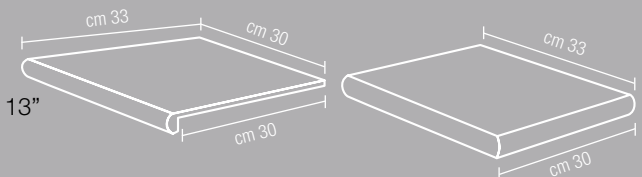

Gradone (assemblato)
cm 30x33 - 11³/₄"x 13"
cm 60x33 - 23⁵/₈"x13"

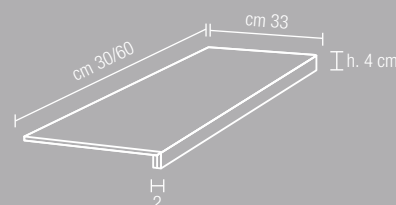

Angolare (assemblato)
cm 30x33 - 11³/₄"x 13"
cm 60x33 - 23⁵/₈"x13"

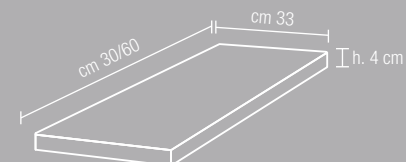

SUPERFICI SURFACES SURFACES OBERFLÄCHEN

meteor
PIETRE NATIVE

lappata

naturale matt naturelle matt R10



matita meteor brown cm 1,2x30 - 1/2"x11³/₄"
deco meteor brown A e B,
meteor brown cm 30x60 - 11³/₄"x23⁵/₈"

DECORI DECORS DÉCORS DEKORE

meteor
PIETRE NATIVE

decoro A*

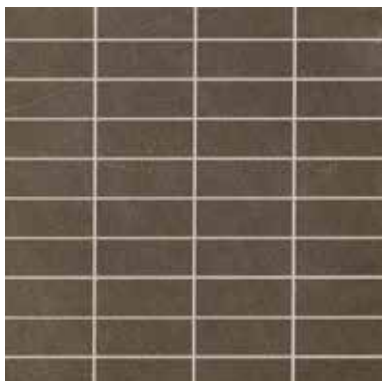

cm 30x30 - 11³/₄"x11³/₄"
tessera cm 2,5x7,5 - 1"x3"

decoro B*



cm 30x30 - 11³/₄"x11³/₄"
tessera cm 7,5x15 - 3"x5⁷/₈"

mosaico 3x3*

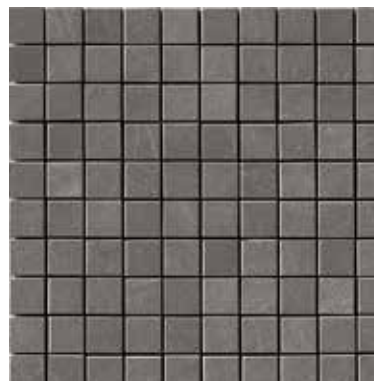

cm 30x30 - 11³/₄"x11³/₄"
tessera cm 3x3 - 1¹/₈"x1¹/₈"
su rete on net sur trame auf Netz

mosaico 6x6*



cm 30x30 - 11³/₄"x11³/₄"
tessera cm 6x6 - 2³/₈"x2³/₈"
su rete on net sur trame auf Netz

decoro C*



cm 30x60 - 11³/₄"x23⁵/₈"
listello cm 1,5x60 - 1/2"x23⁵/₈"

decoro D*



cm 30x60 - 11³/₄"x23⁵/₈"
listello cm 7,5x60 - 3"x23⁵/₈"

* Disponibile in tutti i colori della serie, superficie naturale e lappata.
Available in all the colours of the series, matt and "lappata" surface.
Disponibile dans toutes les couleurs de la série, surface naturelle et "lappata".
Verfügbar in allen Farben, matte und "lappata" Oberfläche.

Complementi in acciaio e alluminio a pagina
Technical features on page
Caractéristiques techniques à la page
Technische eigenschaften auf Seite
457

mineral chrom grey

mineral chrom

PIETRE NATIVE



mineral grey cm 30x60 - 11³/₄"x23⁵/₈", cm 30x30 - 11³/₄"x11³/₄"

COLORI COLOURS COULEURS FARBEN

mineral black



mineral grey



mineral white



mineral brown



mineral gold



mineral beige





mineral chrom

PIETRE NATIVE



mineral beige cm 30x60 - 11³/₄"x23⁵/₈"

FORMATI SIZES FORMATS FORMATE

Formati Sizes Formats Formate	 cm 15x15* 5 ⁷ / ₈ "x5 ⁷ / ₈ "	 cm 15x30* 5 ⁷ / ₈ " x11 ³ / ₄ "	 cm 30x30 11 ³ / ₄ "x11 ³ / ₄ "	 cm 30x60 11 ³ / ₄ "x23 ⁵ / ₈ "
Superfici Surfaces Surfaces Oberflächen	●	●	● ●	● ●
Spessori Thicknesses Epaisseurs Stärken	mm 8,3	mm 8,3	mm 9,4	mm 9,4

- Naturale Matt Naturelle Matt **R11**
- Soft **R10**

* Non rettificato unico calibro.
Unrectified, monocalibre.
Non rectifié dans un calibre unique.
Nicht kalibriert Einziges Kaliber.



Accentuata
Accentuated
Forte
Akzentuiert

Caratteristiche tecniche e imballi a pagina
Technical features and packing on page
Caractéristiques techniques et emballages à la page
Technische Eigenschaften und Verpackungen auf Seite
448

Rettificate in un unico calibro. Single caliber, rectified version.
Rectifiés en un unique calibre. Einem einzigen Werkmass maßgeschliffen geliefert.

Nel caso di combinazioni di formati di spessori diversi, specificarlo espressamente nell'ordine.
Please specify in your order if you wish to purchase formats including more than one thickness.
Prière de spécifier dans votre commande si vous souhaitez acheter des formats avec différentes épaisseurs.
Bitte weisen Sie im Bestellungsformular ausdrücklich darauf hin, wenn Sie Formatkombinationen mit verschiedenen Stärken wünschen.

PEZZI SPECIALI TRIMS ACCESSOIRES FORMSTÜCKE

Battiscopa Bullnose
Plinthe à bord arrondi Stehsockel
cm 9x30 - 3¹/₂"x11³/₄"



Gradino Step tread
Nez de marche Stufenplatte
cm 30x30 - 11³/₄"x11³/₄"
cm 30x60 - 11³/₄"x23⁵/₈"

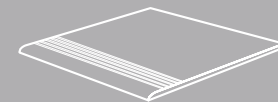

Tozzetto Insert
Cabochon Einleger
cm 9x9 - 3¹/₂"x 3¹/₂"



Listello Listel
Listel Zeilerleiste
cm 9x30 - 3¹/₂"x11³/₄"



Terminale Pezzo unico pressato
Pièce unique pressée
Pressed single piece
Gepresstes Einzelstück
cm 15x30x5 - 5⁷/₈"x11³/₄"x2"

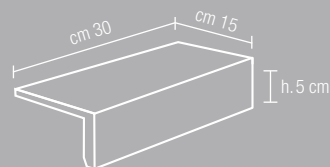

Gradone (assemblato)
cm 30x33 - 11³/₄"x 13"

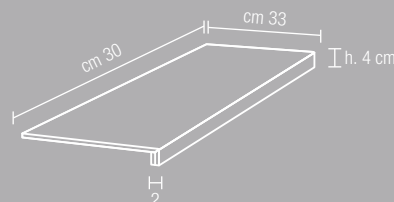

Angolare (assemblato)
cm 30x33 - 11³/₄"x 13"

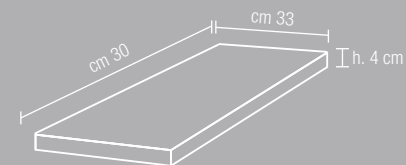

DECORI DECORS DÉCORS DEKORE

mineral chrom

PIETRE NATIVE

mosaico 3x3*



cm 30x30 - 11³/₄"x11³/₄"
 tessera cm 3x3 - 1¹/₈"x1¹/₈"
 su rete on net sur trame auf Netz

mosaico 6x6*



cm 30x30 - 11³/₄"x11³/₄"
 tessera cm 6x6 - 2³/₈"x2³/₈"
 su rete on net sur trame auf Netz

composizione A**



cm 30x60 - 11³/₄"x23⁵/₈"
 su rete on net sur trame auf Netz

decoro**



cm 30x60 - 11³/₄"x23⁵/₈"



mosaico mineral brown cm 30x30 - 11³/₄"x11³/₄"
mineral brown cm 30x60 - 11³/₄"x23⁵/₈"

* Disponibile in tutti i colori della serie, superficie naturale e "soft".
 Available in all the colours of the series, matt and "soft" surface.
 Disponible dans toutes les couleurs de la série, surface naturelle et "soft".
 Verfügbar in allen Farben, matte und "soft" Oberfläche.

** Disponibile in tutti i colori della serie su superficie "soft".
 Available in all the "soft" colours.
 Disponible dans toutes les couleurs pour la surface "soft".
 Verfügbar in allen Farben der Serie, "soft" Oberfläche.

Complementi in acciaio e alluminio a pagina
 Technical features on page
 Caractéristiques techniques à la page
 Technische eigenschaften auf Seite
457

pietra baugé grigia

pietra baugé

PIETRE NATIVE



baugé grigia cm 60x60 - 23⁵/₈"x23⁵/₈"

COLORI COLOURS COULEURS FARBEN

baugé antracite



baugé grigia

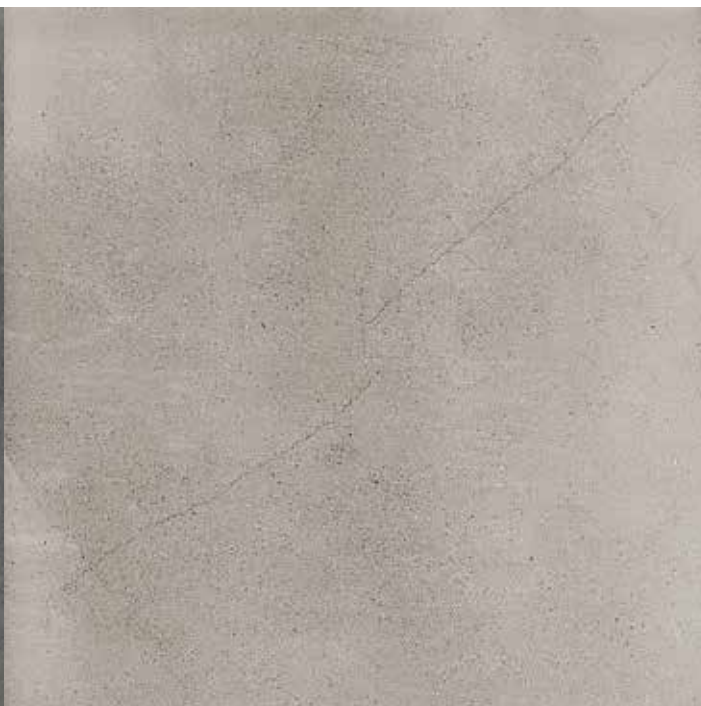

baugé beige

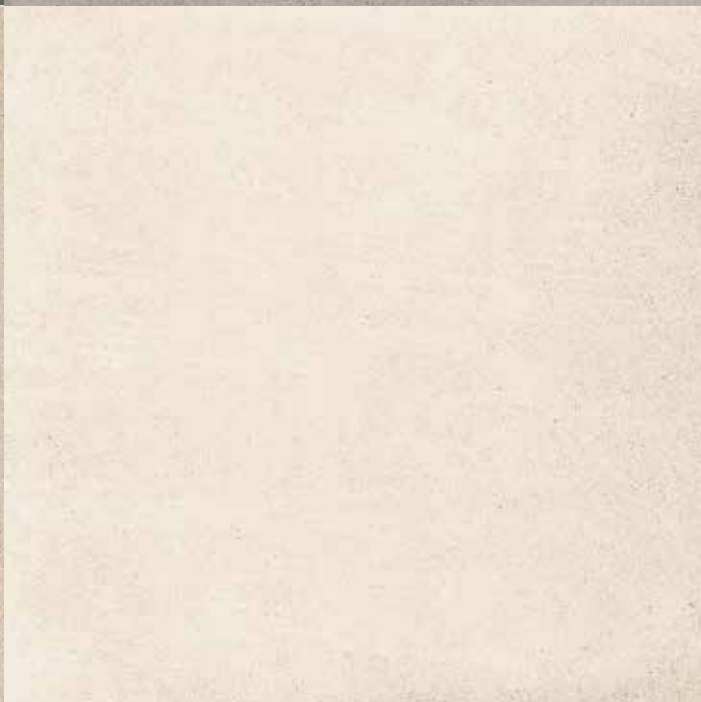

baugé bianca

FORMATI SIZES FORMATS FORMATE

pietra baugé
PIETRE NATIVE

Formati Sizes Formats Formate		
	cm 30x60 11 ³ / ₄ "x23 ⁵ / ₈ "	cm 60x60 23 ⁵ / ₈ "x23 ⁵ / ₈ "
Superfici Surfaces Surfaces Oberflächen	●	●
Spessori Thicknesses Epaisseurs Stärken	mm 10 mm 9,4 mm 9,4**	mm 20* mm 10
● Naturale Matt Naturelle Matt R10 A+B * R11 A+B+C	 Accentuata Accentuated Forte Akzentuiert	Caratteristiche tecniche e imballi a pagina Technical features and packing on page Caractéristiques techniques et emballages à la page Technische Eigenschaften und Verpackungen auf Seite 448
** Non rettificato. Unrectified. Non rectifié. Nicht kalibriert.		

PEZZI SPECIALI TRIMS ACCESSOIRES FORMSTÜCKE

Battiscopa Bullnose
Plinthe à bord arrondi Stehsockel
cm 9x60 - 3¹/₂"x23⁵/₈"



Gradino Step tread
Nez de marche Stufenplatte
cm 30x60 - 11³/₄"x23⁵/₈"



Gradone (assemblato)
cm 60x33 - 23⁵/₈"x13"

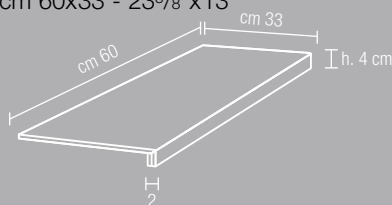

Angolare (assemblato)
cm 60x33 - 23⁵/₈"x13"

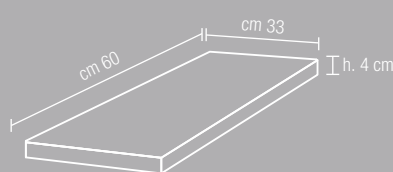

Terminale Pezzo incollato
Glued piece
Pièce collee
Geklebter Stück
cm 15x30x5 - 5⁷/₈"x11³/₄"x2"

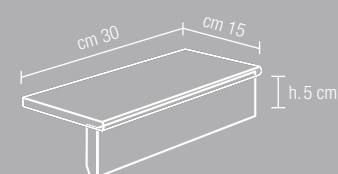

Art. 9640 Bordo
cm 30x60 - 11³/₄"x23⁵/₈"



Art. 9642 Bordo angolare esterno
cm 30x60 - 11³/₄"x23⁵/₈"

2pcs  45°



Art. 9641 Bordo angolare interno
cm 30x60 - 11³/₄"x23⁵/₈"

2pcs  45°



DECORI DECORS DÉCORS DEKORE

mosaico 6x6*



cm 30x30 - 11³/₄"x11³/₄"
 tessera cm 6x6 - 2³/₈"x2³/₈"
su rete on net sur trame auf Netz

mosaico 10x10*



cm 30x30 - 11³/₄"x11³/₄"
 tessera cm 10x10 - 4"x4"
su rete on net sur trame auf Netz

esagono*



cm 30x51,9 - 11³/₄"x20³/₈"

* Disponibile in tutti i colori della serie.
 Available in all the colours of the series.
 Disponible dans tous les couleurs de la série.
 Verfügbar in allen Farben.



baugé bianca cm 60x60 - 23⁵/₈"x23⁵/₈", **mosaico baugé bianco 10x10** cm 30x30 - 11³/₄"x11³/₄"

pietra baugé

PIETRE NATIVE



mosaico baugé antracite 10x10 cm 30x30 - 11³/₄"x11³/₄"
 esagono baugé antracite cm 30x51,9 - 11³/₄"x20³/₈"

pietre di sardegna cala luna

pietre di sardegna

PIETRE NATIVE



cala luna cm 45x90 - 17³/₄"x35³/₈"

COLORI COLOURS COULEURS FARBEN

tavolara



caprera



punta molara



pevero



cala luna



stintino

pietre di sardegna

PIETRE NATIVE

porto rotondo



porto cervo



cala luna
cm 90x90 - 35³/₈"x35³/₈"

FORMATI SIZES FORMATS FORMATE

Formati Sizes Formats Formate	cm 15x15 57/8"x57/8"	cm 30x30 113/4"x113/4"	cm 45x45 173/4"x173/4"	cm 15x60 57/8"x235/8"	cm 30x60 113/4"x235/8"	cm 60x60 235/8"x235/8"	cm 45x90 173/4"x353/8"	cm 90x90 353/8"x353/8"	cm 60x120 235/8"x471/4"
Superfici Surfaces Surfaces Oberflächen	● ●	● ●	● ●	● ●	● ●	● ●	● ●	● ●	● ●
Spessori Thicknesses Epaisseurs Stärken	mm 9,4	mm 9,4	mm 9 mm 4,9	mm 9,4	mm 10,5 mm 9,4	mm 10,5 mm 4,9	mm 10,5 mm 4,9	mm 10,5	mm 10,5 mm 4,9

- Naturale Matt Naturelle Matt **R10A**
- Lappata

Rettificate in un unico calibro. Single caliber, rectified version.
Rectifiés en un unique calibre. Einem einzigen Werkmass maßgeschliffen geliefert.

Nel caso di combinazioni di formati di spessori diversi, specificarlo espressamente nell'ordine.
Please specify in your order if you wish to purchase formats including more than one thickness.
Prière de spécifier dans votre commande si vous souhaitez acheter des formats avec différentes épaisseurs.
Bitte weisen Sie im Bestellungsformular ausdrücklich darauf hin, wenn Sie Formatkombinationen mit verschiedenen Stärken wünschen.



Caratteristiche tecniche e imballi a pagina
Technical features and packing on page
Caractéristiques techniques et emballages à la page
Technische Eigenschaften und Verpackungen auf Seite
448

PEZZI SPECIALI TRIMS ACCESSOIRES FORMSTÜCKE

Battiscopa Bullnose
Plinthe à bord arrondi Stehsockel
cm 9x30 - 3 1/2"x11 3/4"
cm 9x45 - 3 1/2"x17 3/4"
cm 9x60 - 3 1/2"x23 5/8"
cm 9x90 - 3 1/2"x35 3/8"



Gradino Step tread
Nez de marche Stufenplatte
cm 30x30 - 11 3/4"x11 3/4"
cm 45x45 - 17 3/4"x17 3/4"
cm 30x60 - 11 3/4"x23 5/8"

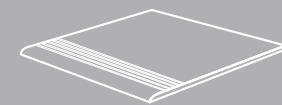

Tozzetto Insert
Cabochoon Einleger
cm 9x9 - 3 1/2"x 3 1/2"



Listello Listel
Listel Zeilerleiste
cm 9x30 - 3 1/2"x11 3/4"
cm 9x45 - 3 1/2"x17 3/4"



Terminale Pezzo incollato
Glued piece
Pièce collee
Geklebter Stück
cm 15x30x5 - 5 7/8"x11 3/4"x2"

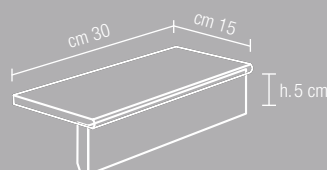

Scalino
e scalino angolare
cm 30x33 - 11 3/4"x 13"

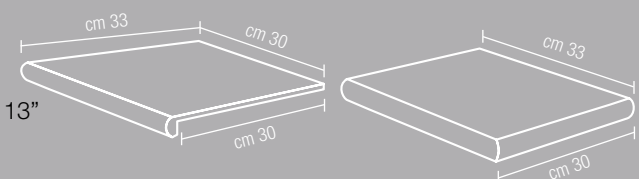

SUPERFICI SURFACES SURFACES OBERFLÄCHEN

pietre di sardegna
PIETRE NATIVE

lappata

naturale matt naturelle matt R10A

DECORI DECORS DÉCORS DEKORE

mosaico 3x3*



cm 30x30 - 11³/₄"x11³/₄"
 tessera cm 3x3 - 1¹/₈"x1¹/₈"
su rete on net sur trame auf Netz

mosaico 6x6*



cm 30x30 - 11³/₄"x11³/₄"
 tessera cm 6x6 - 2³/₈"x2³/₈"
su rete on net sur trame auf Netz

decoro E*



cm 30x30 - 11³/₄"x11³/₄"
 listello cm 1,5x15 - 1/2"x5⁷/₈"

composizione A*



cm 30x60 - 11³/₄"x23⁵/₈"
su rete on net sur trame auf Netz

composizione C*

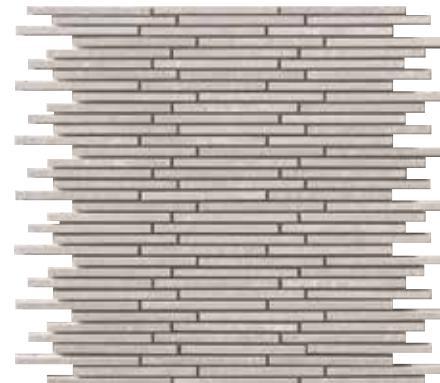

cm 30x30 - 11³/₄"x11³/₄"
su rete on net sur trame auf Netz

fascia sardegna A



cm 5x30 - 2"x11³/₄"
 punta molara, tavolara,
 lavagna bianca

fascia sardegna B



cm 5x30 - 2"x11³/₄"
 cala luna, porto cervo,
 porto rotondo

* Disponibile in tutti i colori della serie,
 superficie naturale e lappata.
 Available in all the colours of the series,
 matt and "lappata" surface.
 Disponible dans toutes les couleurs
 de la série, surface naturelle et "lappata".
 Verfügbar in allen Farben,
 matte und "lappata" Oberfläche.

Complementi in acciaio e alluminio a pagina
 Technical features on page
 Caractéristiques techniques à la page
 Technische eigenschaften auf Seite
457

pietre di sardegna

PIETRE NATIVE

tavolara, porto rotondo cm 30x60 - 11³/₄"x23⁵/₈"
composizione A porto rotondo cm 30x60 - 11³/₄"x23⁵/₈"
deco E porto rotondo cm 30x30 - 11³/₄"x11³/₄"

stonewash wash brown

stonewash

GRANITOKER



wash brown cm 30X180 - 11³/₄"X70⁷/₈"

COLORI COLOURS COULEURS FARBEN

wash brown



wash grey



wash cream







stonewash

GRANITOKER

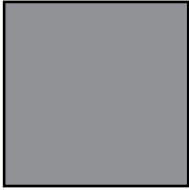

wash grey cm 22,5X180 - 87/8"x707/8", listone wash grey cm 22,5X180 - 87/8"x707/8"

FORMATI SIZES FORMATS FORMATE

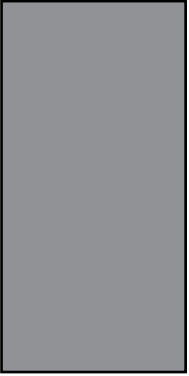
							
Formati Sizes Formats Formate	cm 60x60 23 ⁵ / ₈ "x23 ⁵ / ₈ "	cm 90x90 35 ³ / ₈ "x35 ³ / ₈ "	cm 60x120 23 ⁵ / ₈ "x47 ¹ / ₄ "	cm 22,5x180 8 ⁷ / ₈ "x70 ⁷ / ₈ "	cm 30x180 11 ³ / ₄ "x70 ⁷ / ₈ "	cm 45x180 17 ³ / ₄ "x70 ⁷ / ₈ "	cm 90x180 35 ³ / ₈ "x70 ⁷ / ₈ "
Superfici Surfaces Surfaces Oberflächen	●	●	●	●	●	●	●
Spessori Thicknesses Epaisseurs Stärken	mm 10	mm 10	mm 10	mm 10	mm 10	mm 10	mm 10

● Naturale Matt Naturelle Matt **R9**



Media
Medium
Moyenne
Mittel

Caratteristiche tecniche e imballi a pagina
Technical features and packing on page
Caractéristiques techniques et emballages à la page
Technische Eigenschaften und Verpackungen auf Seite
450

PEZZI SPECIALI TRIMS ACCESSOIRES FORMSTÜCKE

Battiscopa Bullnose
Plinthe à bord arrondi Stehsockel
cm 9x90 - 3¹/₂"x35³/₈"
cm 9x60 - 3¹/₂"x23⁵/₈"



Gradino Step tread
Nez de marche Stufenplatte
cm 30x90 - 11³/₄"x35³/₈"
cm 30x60 - 11³/₄"x23⁵/₈"



Gradone (assemblato)
cm 90x33 - 35³/₈"x13"
cm 120x33 - 47¹/₄"x13"

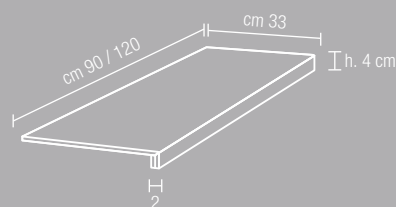

Angolare (assemblato)
cm 90x33 - 35³/₈"x13"
cm 120x33 - 35³/₈"x47¹/₄"

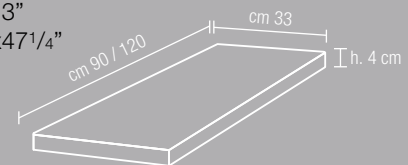

DECORI DECORS DÉCORS DEKORE

stonewash
GRANITOKER

mosaico 6x6*



cm 30x30 - 11³/₄"x11³/₄"
 tessera cm 6x6 - 2³/₈"x2³/₈"
su rete on net sur trame auf Netz

composizione D*



cm 28,5x57,6 - 11¹/₄"x22⁵/₈"
 mattoncino cm 7x28 - 2³/₄"x11¹/₄"
su rete on net sur trame auf Netz

* Disponibile in tutti
 i colori della serie.
 Available in all
 the colours of the series.
 Disponible dans tous
 les couleurs de la série.
 Verfügbar in allen farben.

listone wash*



cm 22,5x180 - 8⁷/₈"x70⁷/₈"

terre toscane san casciano

terre toscane

PIETRE NATIVE



san casciano cm 30x60 - 11³/₄"x23⁵/₈"

COLORI COLOURS COULEURS FARBEN

montepulciano



gaiole



greve



volpaia



san gimignano



verrazzano

terre toscane

PIETRE NATIVE

san casciano







monteriggioni



verrazzano
cm 30x60 - 11³/₄"x23⁵/₈"

FORMATI SIZES FORMATS FORMATE

Formati Sizes Formats Formate	 cm 30x30 11 ³ / ₄ "x11 ³ / ₄ "	 cm 30x60 11 ³ / ₄ "x23 ⁵ / ₈ "	 cm 60x60 23 ⁵ / ₈ "x23 ⁵ / ₈ "	 cm 45x90 17 ³ / ₄ "x35 ³ / ₈ "
Superfici Surfaces Surfaces Oberflächen	● ●	● ●	● ●	● ●
Spessori Thicknesses Epaisseurs Stärken	mm 9,4	mm 10,5 mm 9,4	mm 10,5	mm 10,5

- Naturale Matt Naturelle Matt **R9**
- Lappata



Caratteristiche tecniche e imballi a pagina
 Technical features and packing on page
 Caractéristiques techniques et emballages à la page
 Technische Eigenschaften und Verpackungen auf Seite
448

Rettificata in un unico calibro. Single caliber, rectified version.
 Rectifiés en un unique calibre. Einem einzigen Werkmass maßgeschliffen geliefert.

Nel caso di combinazioni di formati di spessori diversi, specificarlo espressamente nell'ordine.
 Please specify in your order if you wish to purchase formats including more than one thickness.
 Prière de spécifier dans votre commande si vous souhaitez acheter des formats avec différentes épaisseurs.
 Bitte weisen Sie im Bestellungsformular ausdrücklich darauf hin, wenn Sie Formatkombinationen mit verschiedenen Stärken wünschen.

PEZZI SPECIALI TRIMS ACCESSOIRES FORMSTÜCKE

Battiscopa Bullnose
Plinthe à bord arrondi Stehsockel
 cm 9x30 - 3¹/₂"x11³/₄"
 cm 9x60 - 3¹/₂"x23⁵/₈"
 cm 9x90 - 3¹/₂"x35³/₈"



Gradino Step tread
Nez de marche Stufenplatte
 cm 30x30 - 11³/₄"x11³/₄"
 cm 30x60 - 11³/₄"x23⁵/₈"

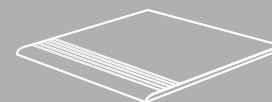

Tozzetto Insert
Cabochoon Einleger
 cm 9x9 - 3¹/₂"x 3¹/₂"



Listello Listel
Listel Zeierleiste
 cm 9x30 - 3¹/₂"x11³/₄"



Terminale Pezzo incollato
 Glued piece
 Pièce collee
 Geklebter Stück
 cm 15x30x5 - 5⁷/₈"x11³/₄"x2"

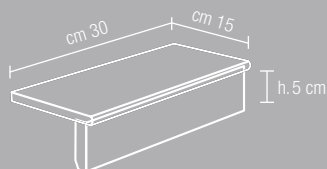

Scalino e scalino angolare
 cm 30x33 - 11³/₄"x 13"

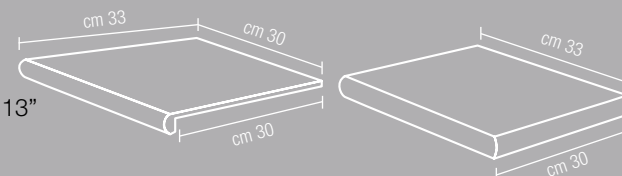

SUPERFICI SURFACES SURFACES OBERFLÄCHEN

terre toscane

PIETRE NATIVE

lappata

naturale matt naturelle matt R9

DECORI DECORS DÉCORS DEKORE

mosaico
terre toscane A

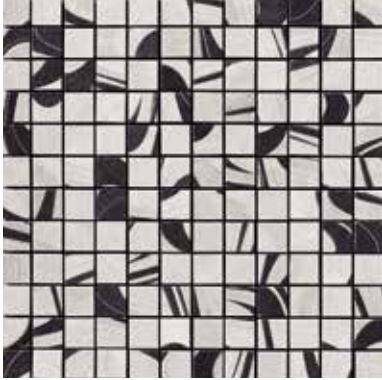

cm 30x30 - 11³/₄"x11³/₄"
tessera cm 2,2x2,2 - 7/₈"x7/₈"
su rete on net sur trame auf Netz
san casciano
naturale matt naturelle Matt

mosaico
terre toscane B

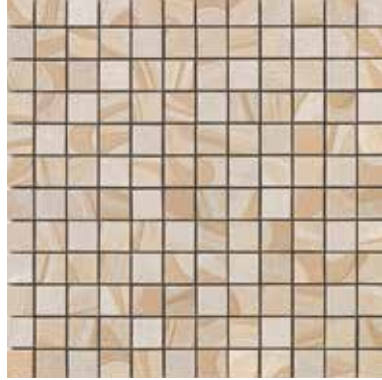

cm 30x30 - 11³/₄"x11³/₄"
tessera cm 2,2x2,2 - 7/₈"x7/₈"
su rete on net sur trame auf Netz
verrazzano
naturale matt naturelle Matt

composizione A*

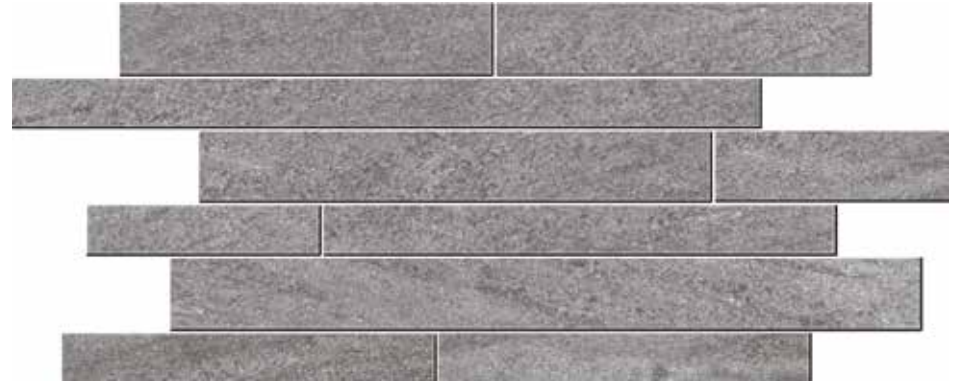

cm 30x60 - 11³/₄"x23⁵/₈"
su rete on net sur trame auf Netz

mosaico 3x3*



cm 30x30 - 11³/₄"x11³/₄"
tessera cm 3x3 - 11/₈"x11/₈"
su rete on net sur trame auf Netz

mosaico 6x6*



cm 30x30 - 11³/₄"x11³/₄"
tessera cm 6x6 - 2³/₈"x2³/₈"
su rete on net sur trame auf Netz

chiusura A*



cm 4x60 - 1⁵/₉"x23⁵/₈"

decoro*



cm 30x60 - 11³/₄"x23⁵/₈"

chiusura B*



cm 6x60 - 2³/₈"x23⁵/₈"

* Disponibile in tutti i colori della serie, superficie naturale e lappata.
Available in all the colours of the series, matt and "lappata" surface.
Disponibile dans toutes les couleurs de la série, surface naturelle et "lappata".
Verfügbar in allen Farben, matte und "lappata" Oberfläche.

terre toscane

PIETRE NATIVE

mosaico terre toscane A
san casciano cm 30x30 - 11³/₄"x11³/₄"
san casciano, montepulciano
 cm 30x60 - 11³/₄"x23⁵/₈"

pietre etrusche tuscania

pietre etrusche

PIETRE NATIVE



tuscania cm 60x120 - 23⁵/₈"x47¹/₄"

COLORI COLOURS COULEURS FARBEN

manciano



vulci



capalbio



sovana

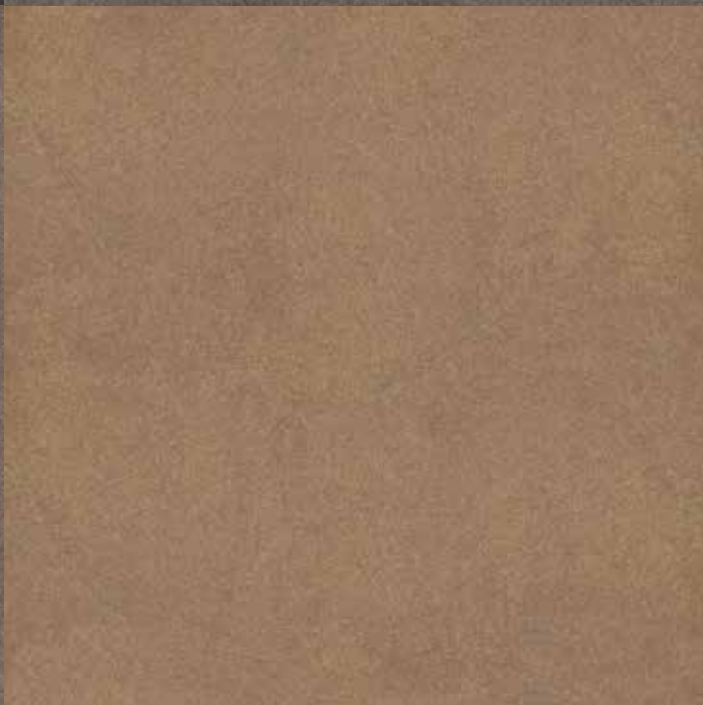

santa fiora



pitigliano

pietre etrusche

PIETRE NATIVE

paestum



tarquinia



tuscania



saturnia



manciano

cm 60x60 - 23⁵/₈"x23⁵/₈"
cm 30x60 - 11³/₄"x23⁵/₈"

FORMATI SIZES FORMATS FORMATE

Formati Sizes Formats Formate	cm 15x15 5 ⁷ / ₈ "x5 ⁷ / ₈ "	cm 30x30 11 ³ / ₄ "x11 ³ / ₄ "	cm 45x45 17 ³ / ₄ "x17 ³ / ₄ "	cm 15x60 5 ⁷ / ₈ "x23 ⁵ / ₈ "	cm 30x60 11 ³ / ₄ "x23 ⁵ / ₈ "	cm 60x60 23 ⁵ / ₈ "x23 ⁵ / ₈ "	cm 45x90 17 ³ / ₄ "x35 ³ / ₈ "	cm 60x120 23 ⁵ / ₈ "x47 ¹ / ₄ "
Superfici Surfaces Surfaces Oberflächen	● ●	● ●	● ●	● ●	● ●	● ●	● ●	● ●
Spessori Thicknesses Epaisseurs Stärken	mm 9,4	mm 9,4 mm 8,2*	mm 9 mm 9* mm 4,9	mm 9,4	mm 10,5 mm 9,4* mm 9,4*	mm 10,5 mm 10,5* mm 4,9	mm 10,5 mm 4,9	mm 10,5 mm 4,9

- Naturale Matt Naturelle Matt **R9**
- Lappata



Leggera
Subtle
Légère
Leicht

Caratteristiche tecniche e imballi a pagina
Technical features and packing on page
Caractéristiques techniques et emballages à la page
Technische Eigenschaften und Verpackungen auf Seite
448

Nel caso di combinazioni di formati di spessori diversi, specificarlo espressamente nell'ordine.
Please specify in your order if you wish to purchase formats including more than one thickness.
Prière de spécifier dans votre commande si vous souhaitez acheter des formats avec différentes épaisseurs.
Bitte weisen Sie im Bestellungsformular ausdrücklich darauf hin, wenn Sie Formatkombinationen mit verschiedenen Stärken wünschen.

* Solo naturale, versione non rettificata e solo nei colori:
Only matt, not rectified version and only in the colours:
Seulement naturel, version non rectifiée et seulement dans les couleurs :
Nur matt, in der nicht rektifizierte Version und in die Farben:
Manciano, Sovana, Capalbio, Tuscania, Paestum, Saturnia

PEZZI SPECIALI TRIMS ACCESSOIRES FORMSTÜCKE

Battiscopa Bullnose
Plinthe à bord arrondi Stehsockel
cm 9x30 - 3¹/₂"x11³/₄"
cm 9x45 - 3¹/₂"x17³/₄"
cm 9x60 - 3¹/₂"x23⁵/₈"



Gradino Step tread
Nez de marche Stufenplatte
cm 30x30 - 11³/₄"x11³/₄"
cm 45x45 - 17³/₄"x17³/₄"
cm 30x60 - 11³/₄"x23⁵/₈"

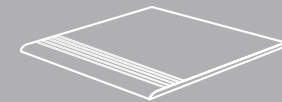

Tozzetto Insert
Cabochoon Einleger
cm 9x9 - 3¹/₂"x 3¹/₂"



Listello Listel
Listel Zeilerleiste
cm 9x30 - 3¹/₂"x11³/₄"
cm 9x45 - 3¹/₂"x17³/₄"



Terminale Pezzo incollato
Glued piece
Pièce collée
Geklebter Stück
cm 15x30x5 - 5⁷/₈"x11³/₄"x2"

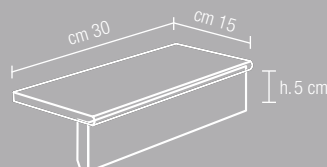

Scalino e scalino angolare
cm 30x33 - 11³/₄"x 13"

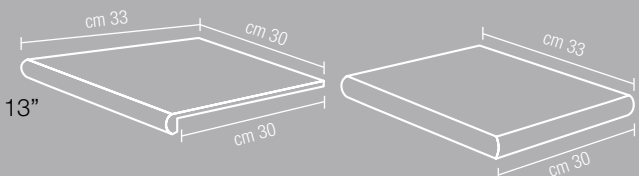

SUPERFICI SURFACES SURFACES OBERFLÄCHEN

pietre etrusche
PIETRE NATIVE

lappata

naturale matt naturelle matt R9

DECORI DECORS DÉCORS DEKORE

decoro A*

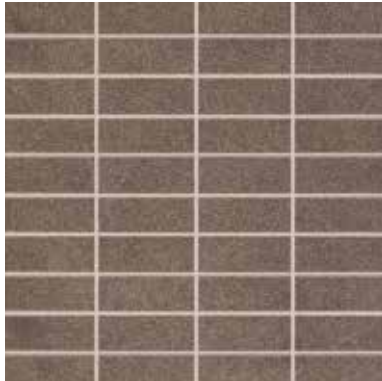

cm 30x30 - 11³/₄"x11³/₄"
tessera cm 2,5x7,5 - 1"x3"

decoro B*



cm 30x30 - 11³/₄"x11³/₄"
tessera cm 7,5x15 - 3"x5⁷/₈"

decoro C*



cm 30x60 - 11³/₄"x23⁵/₈"
listello cm 1,5x60 - 1/2"x23⁵/₈"

fascia etrusca A**



cm 5x45 - 2"x17³/₄"

angolo etrusca A**



cm 5x5 - 2"x2"

decoro D*



cm 30x60 - 11³/₄"x23⁵/₈"
listello cm 7,5x60 - 3"x23⁵/₈"



capalbio cm 45x45 - 17³/₄"x17³/₄"
fascia etrusca B cm 5x45 - 2"x17³/₄"

* Disponibile in tutti i colori della serie, superficie naturale e lappata.
Available in all the colours of the series, matt and "lappata" surface.
Disponibile dans toutes les couleurs de la série, surface naturelle et "lappata".
Verfügbar in allen Farben, matte und "lappata" Oberfläche.

** Disponibile nei colori:
Avalable in the colours:
Disponibile dans les couleurs :
Verfügbar in den folgenden Farben:
A (Pitigliano/Saturnia),
B (Manciano/Capalbio),
C (Tuscania/Santafiora),
D (Paestum/Vulci)

Complementi in acciaio e alluminio a pagina
Technical features on page
Caractéristiques techniques à la page
Technische eigenschaften auf Seite
457

pietre etrusche

PIETRE NATIVE

saturnia cm 60x120 - 23⁵/₈"x47¹/₄"

basaltina linosa

basaltina

PIETRE NATIVE



linosa cm 30x60 - 11³/₄"x23⁵/₈"

COLORI COLOURS COULEURS FARBEN

vulcano



linosa



lipari



stromboli

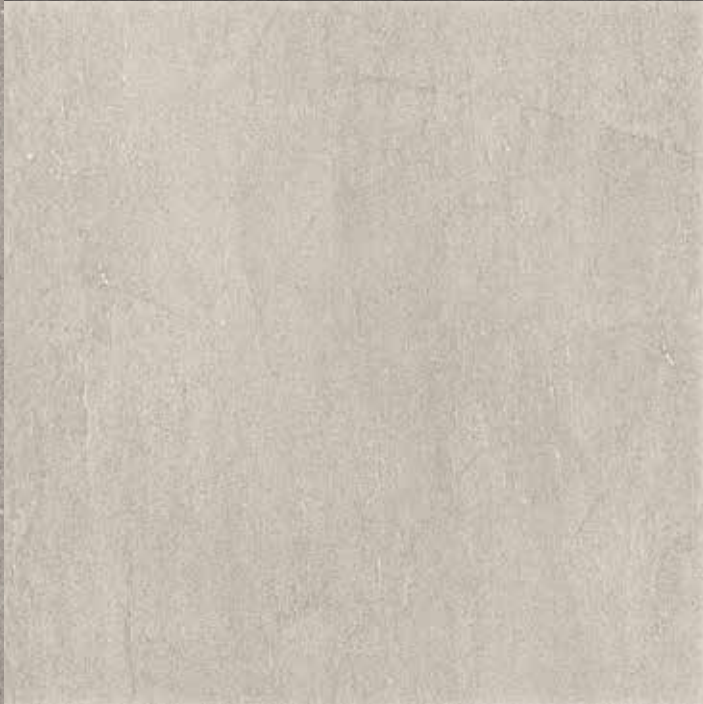

pantelleria



ischia





basaltina

PIETRE NATIVE



iischia cm 45x90 - 17³/₄"x35³/₈"

FORMATI SIZES FORMATS FORMATE

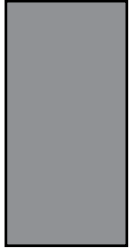
						
Formati Sizes Formats Formate	cm 30x30 11 ³ / ₄ "x11 ³ / ₄ "	cm 45x45 17 ³ / ₄ "x17 ³ / ₄ "	cm 30x60 11 ³ / ₄ "x23 ⁵ / ₈ "	cm 60x60 23 ⁵ / ₈ "x23 ⁵ / ₈ "	cm 45x90 17 ³ / ₄ "x35 ³ / ₈ "	cm 60x120 23 ⁵ / ₈ "x47 ¹ / ₄ "
Superfici Surfaces Surfaces Oberflächen	● ●	● ●	● ●	● ●	● ●	● ●
Spessori Thicknesses Epaisseurs Stärken	mm 9,4	mm 9	mm 10,5 mm 9,4	mm 10,5	mm 10,5	mm 10,5

- Naturale Matt Naturelle Matt **R10 A+B**
- Lappata



Media
Medium
Moyenne
Mittel

Caratteristiche tecniche e imballi a pagina
Technical features and packing on page
Caractéristiques techniques et emballages à la page
Technische Eigenschaften und Verpackungen auf Seite
448

Le piastrelle della serie Basaltina sono fornite rettificate in un unico calibro.
Su richiesta possono essere forniti tutti i formati ottenuti per taglio.
The tiles in the Basaltina series come in a single caliber, rectified version.
All sizes obtained by cutting can be supplied on request.
Les carreaux de la série Basaltina sont fournis rectifiés en un unique calibre.
Sur demande peuvent être fournis tous les formats, obtenus par découpe.
Die Fliesen der Serie Basaltina werden in einem einzigen Werkmass maßgeschliffen geliefert.
Auf Anfrage können alle Formate geschnitten und geliefert werden.

Nel caso di combinazioni di formati di spessori diversi,
specificarlo espressamente nell'ordine.
Please specify in your order if you wish to purchase
formats including more than one thickness.
Prière de spécifier dans votre commande si vous souhaitez
acheter des formats avec différentes épaisseurs.
Bitte weisen Sie im Bestellungsformular ausdrücklich darauf hin, wenn
Sie Formatkombinationen mit verschiedenen Stärken wünschen.

PEZZI SPECIALI TRIMS ACCESSOIRES FORMSTÜCKE

Battiscopa Bullnose
Plinthe à bord arrondi Stehsockel
cm 9x30 - 3¹/₂"x11³/₄"
cm 9x45 - 3¹/₂"x17³/₄"
cm 9x60 - 3¹/₂"x23⁵/₈"



Gradino Step tread
Nez de marche Stufenplatte
cm 30x30 - 11³/₄"x11³/₄"
cm 45x45 - 17³/₄"x17³/₄"
cm 30x60 - 11³/₄"x23⁵/₈"

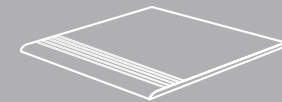

Tozzetto Insert
Cabochoon Einleger
cm 9x9 - 3¹/₂"x 3¹/₂"



Listello Listel
Listel Zeierleiste
cm 9x30 - 3¹/₂"x11³/₄"
cm 9x45 - 3¹/₂"x18"



Terminale Pezzo incollato
Glued piece
Pièce collee
Geklebter Stück
cm 15x30x5 - 5⁷/₈"x11³/₄"x2"

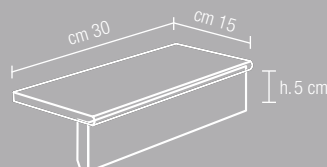

SUPERFICI SURFACES SURFACES OBERFLÄCHEN

basaltina
PIETRE NATIVE

lappata

naturale matt naturelle matt R10 A+B

DECORI DECORS DÉCORS DEKORE

mosaico 3x3*



cm 30x30 - 11³/₄"x11³/₄"
tessera cm 3x3 - 1¹/₈"x1¹/₈"
su rete on net sur trame auf Netz

mosaico 6x6*



cm 30x30 - 11³/₄"x11³/₄"
tessera cm 6x6 - 2³/₈"x2³/₈"
su rete on net sur trame auf Netz

composizione B*



cm 30x60 - 11³/₄"x23⁵/₈"
su rete on net sur trame auf Netz

inserto A*

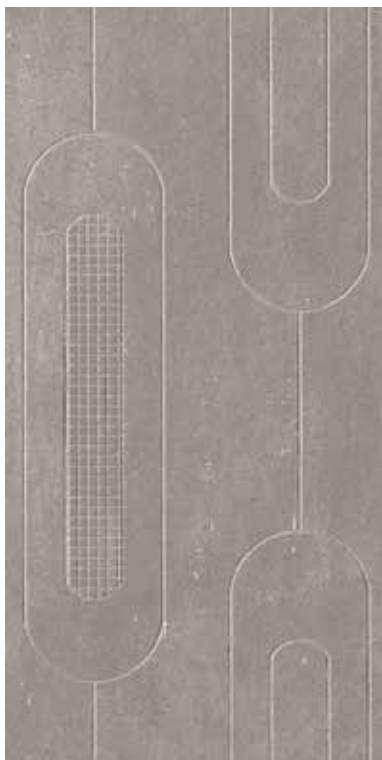

cm 30x60 - 11³/₄"x23⁵/₈"

inserto B*



cm 30x60 - 11³/₄"x23⁵/₈"



inserto A + B pantelleria cm 30x60 - 11³/₄"x23⁵/₈"

* Disponibile in tutti i colori della serie, superficie naturale e lappata.
Available in all the colours of the series, matt and "lappata" surface.
Disponibile dans toutes les couleurs de la série, surface naturelle et "lappata".
Verfügbar in allen Farben, matte und "lappata" Oberfläche.

basaltina
PIETRE NATIVE

vulcano composizione B cm 30x60 - 11³/₄"x23⁵/₈"
mosaico 6x6 vulcano cm 30x30 - 11³/₄"x11³/₄"

DECORI DECORS DÉCORS DEKORE

decoro A*



cm 30x30 - 11³/₄"x11³/₄"
tessera cm 2,5x7,5 - 1"x3"

decoro B*

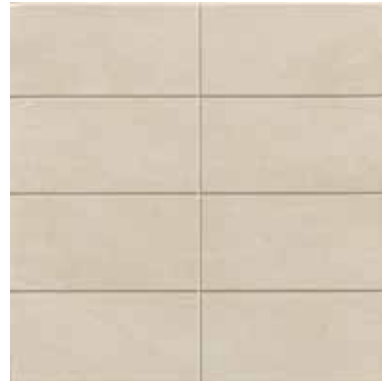

cm 30x30 - 11³/₄"x11³/₄"
tessera cm 7,5x15 - 3"x5⁷/₈"

decoro C*



cm 30x60 - 11³/₄"x23⁵/₈"
listello cm 1,5x60 - 5/8"x23⁵/₈"

decoro D*



cm 30x60 - 11³/₄"x23⁵/₈"
listello cm 7,5x60 - 3"x23⁵/₈"

* Disponibile in tutti i colori della serie, superficie naturale e lappata.
Available in all the colours of the series, matt and "lappata" surface.
Disponibile dans toutes les couleurs de la série, surface naturelle et "lappata".
Verfügbar in allen Farben, matte und "lappata" Oberfläche.

Per mettere in risalto la trama del decoro si consiglia l'utilizzo di fughe colorate in contrasto col colore della piastrella.
We recommend use of coloured grouting that contrasts with the colour of the tiles to emphasize the patterning.
Pour mettre en valeur la trame du décor, nous conseillons d'utiliser des joints colorés en contraste avec la couleur du carreau.
Zur Hervorhebung des Verzierungsmusters empfiehlt es sich, von der Fliesenfarbe abweichende farbige Fugen zu verwenden.



decoro C lipari, decoro D lipari, ischia
lipari naturale matt, lappato
cm 30x60 - 11³/₄"x23⁵/₈"

basaltina

PIETRE NATIVE

decoro A, decoro B stromboli cm 30x30 - 11³/₄"x11³/₄"
stromboli cm 30x60 - 11³/₄"x23⁵/₈"

pietra blue new blue moon

pietra blue

PIETRE NATIVE



new blue moon cm 30x60 - 11³/₄"x23⁵/₈"

COLORI COLOURS COULEURS FARBEN

new blue moon



new blue brut

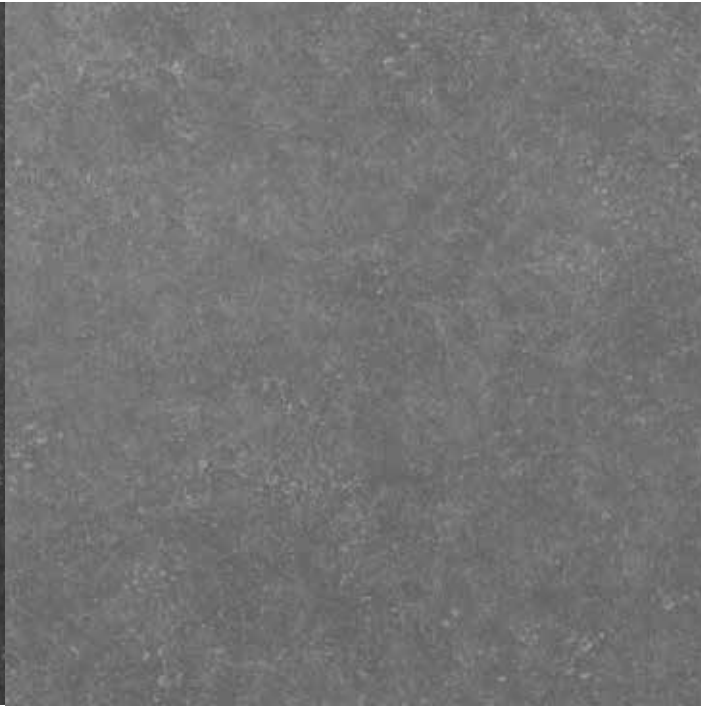

new blue moon cm 30x60 - 11³/₄"x23⁵/₈"

FORMATI SIZES FORMATS FORMATE

pietra blue
PIETRE NATIVE

Formati Sizes
Formats Formate



cm 30x60
11³/₄"x23⁵/₈"



cm 60x60
23⁵/₈"x23⁵/₈"

Superfici Surfaces
Surfaces Oberflächen



Spessori Thicknesses
Epaisseurs Stärken

mm 10

mm 10

- Naturale Matt Naturelle Matt **R10 A+B**

Rettificate in un unico calibro. Single caliber, rectified version.
Rectifiés en un unique calibre. Einem einzigen Werkmass maßgeschliffen geliefert.

Caratteristiche tecniche e imballi a pagina
Technical features and packing on page
Caractéristiques techniques et emballages à la page
Technische Eigenschaften und Verpackungen auf Seite
448

Complementi in acciaio e alluminio a pagina
Technical features on page
Caractéristiques techniques à la page
Technische eigenschaften auf Seite
457

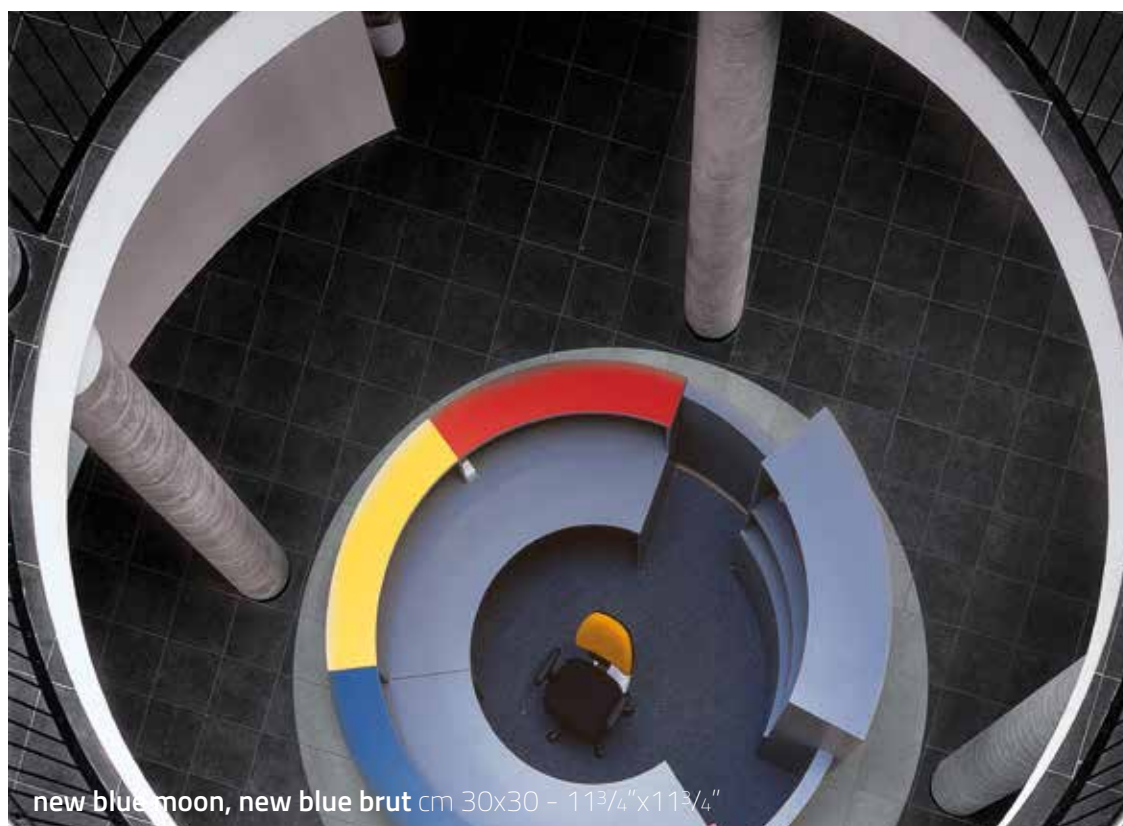

new blue moon, new blue brut cm 30x30 - 11³/₄"x11³/₄"

PEZZI SPECIALI TRIMS ACCESSOIRES FORMSTÜCKE

Battiscopa Bullnose
Plinthe à bord arrondi Stehsockel
cm 9x60 - 3¹/₂"x23⁵/₈"



Gradino Step tread
Nez de marche Stufenplatte
cm 30x60 - 11³/₄"x23⁵/₈"



piacentina

pietra piacentina

PIETRE NATIVE

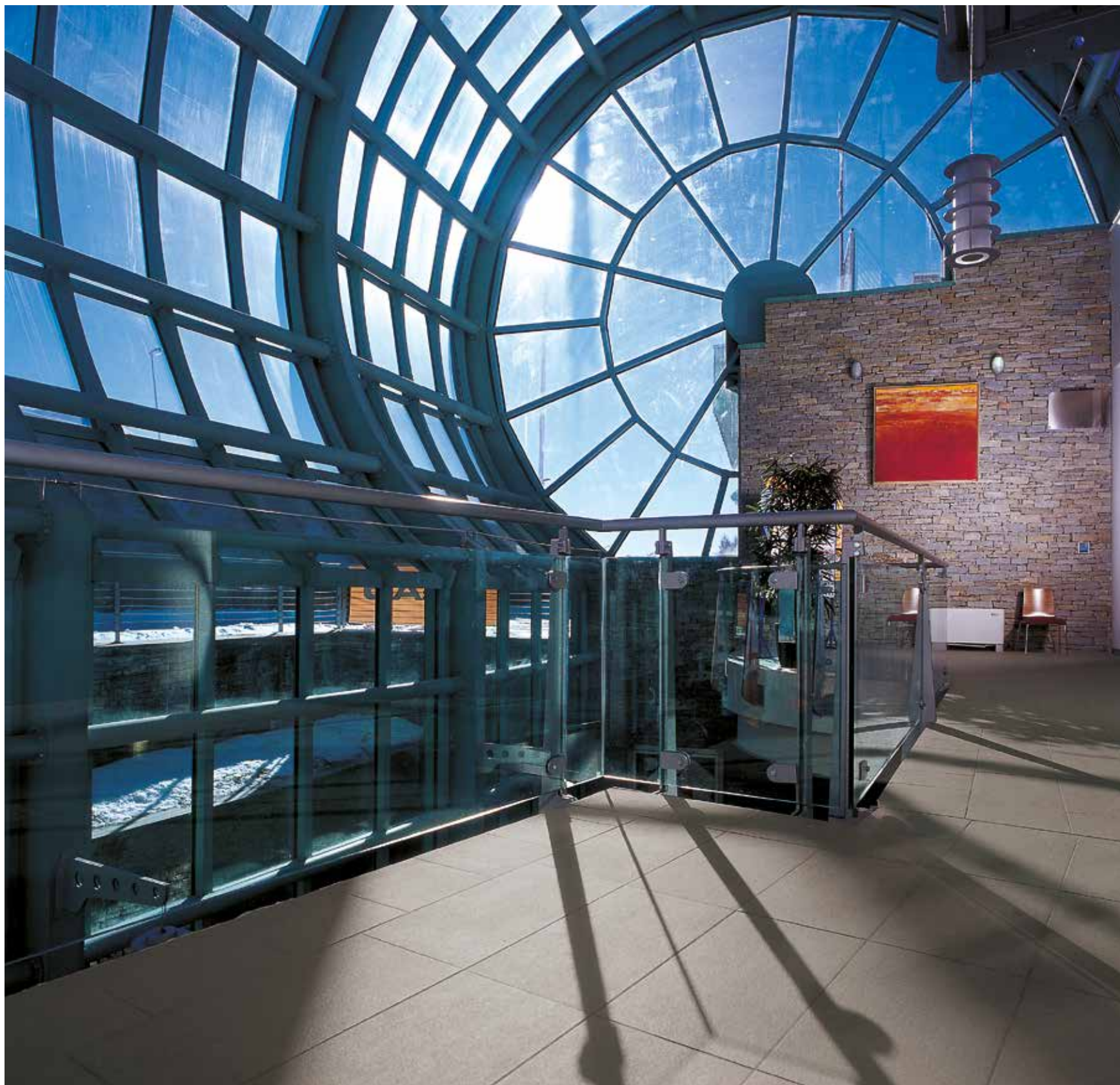

piacentina cm 30x60 - 11³/₄"x23⁵/₈"

FORMATI SIZES FORMATS FORMATE

Formati Sizes
Formats Formate



cm 30x60
11³/₄"x23⁵/₈"

Superfici Surfaces
Surfaces Oberflächen



Spessori Thicknesses
Epaisseurs Stärken

mm 9,4

- NaturaleMatt Naturelle Matt **R10 A+B**



Media
Medium
Moyenne
Mittel

Caratteristiche tecniche e imballi a pagina
Technical features and packing on page
Caractéristiques techniques et emballages à la page
Technische Eigenschaften und Verpackungen auf Seite
448

Rettificate in un unico calibro. Single caliber, rectified version.
Rectifiés en un unique calibre. Einem einzigen Werkmass maßgeschliffen geliefert.

Nel caso di combinazioni di formati di spessori diversi, specificarlo espressamente nell'ordine.
Please specify in your order if you wish to purchase formats including more than one thickness.
Prière de spécifier dans votre commande si vous souhaitez acheter des formats avec différentes épaisseurs.
Bitte weisen Sie im Bestellungsformular ausdrücklich darauf hin, wenn Sie Formatkombinationen mit verschiedenen Stärken wünschen.

PEZZI SPECIALI TRIMS ACCESSOIRES FORMSTÜCKE

Battiscopa Bullnose
Plinthe à bord arrondi Stehsockel
cm 9x30 - 3¹/₂"x11³/₄"



Tozzetto Insert
Cabochon Einleger
cm 9x9 - 3¹/₂"x 3¹/₂"



Gradone Piasentina
Pezzo unico Single piece
Une seule pièce Einzelstück
cm 30x33 - 11³/₄"x13"

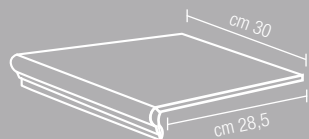

Angolare Piasentina
Pezzo unico Single piece
Une seule pièce Einzelstück
cm 30x33 - 11³/₄"x13"

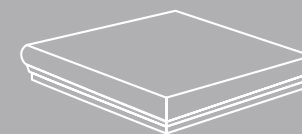

Terminale Pezzo unico pressato
Pièce unique pressée
Pressed single piece
Gepresstes Einzelstück
cm 15x30x3,5 - 5⁷/₈"x11³/₄"x1³/₈"

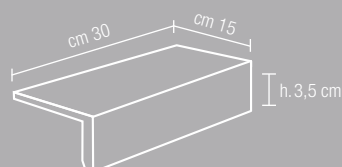

pietra piacentina

PIETRE NATIVE



piacentina cm 30x60 - 11³/₄"x23⁵/₈"

kerblock beige

kerblock

PIETRE NATIVE

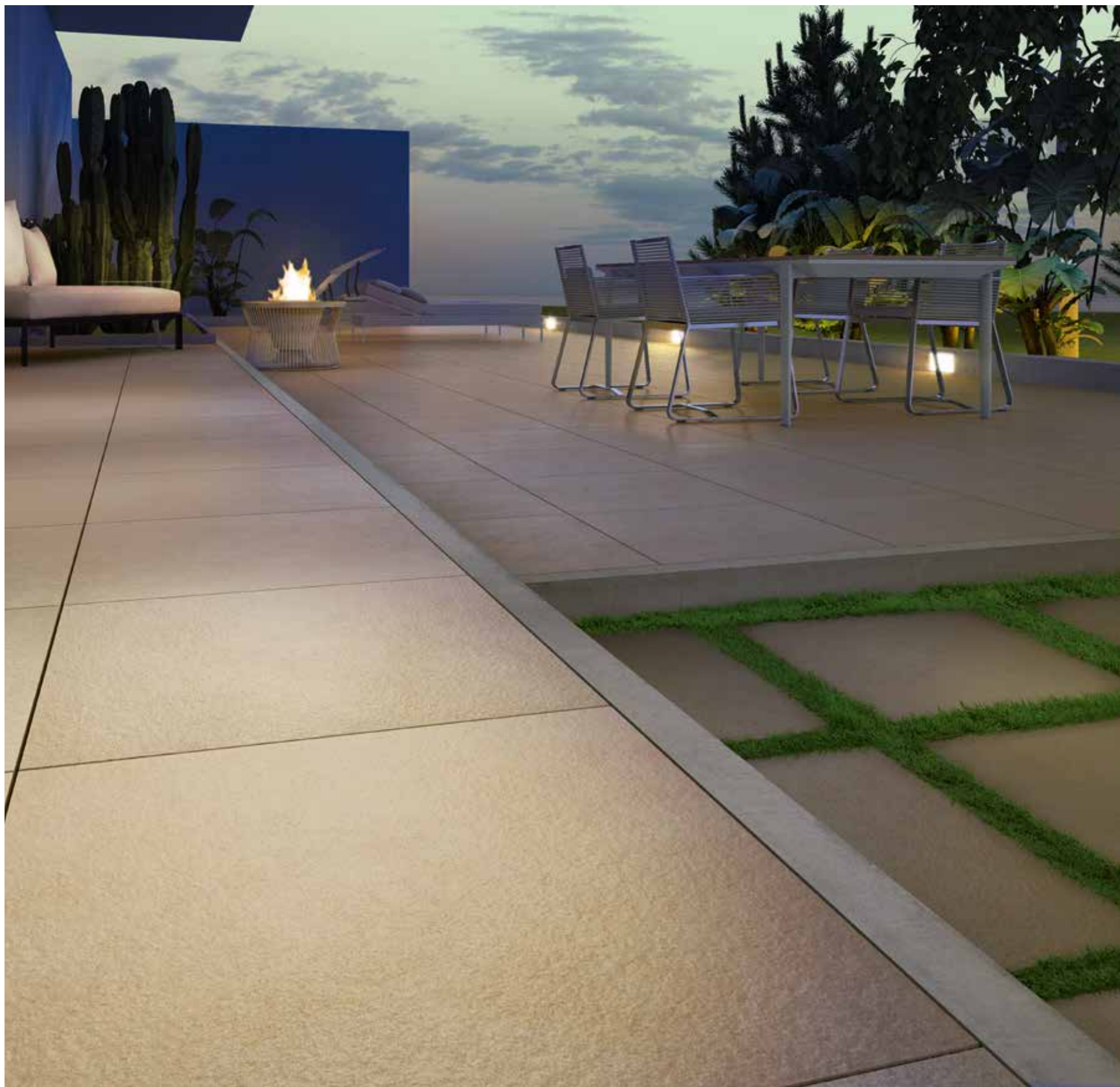

beige cm 60x60 - 23⁵/₈"x23⁵/₈"

COLORI COLOURS COULEURS FARBEN

nero



piombo

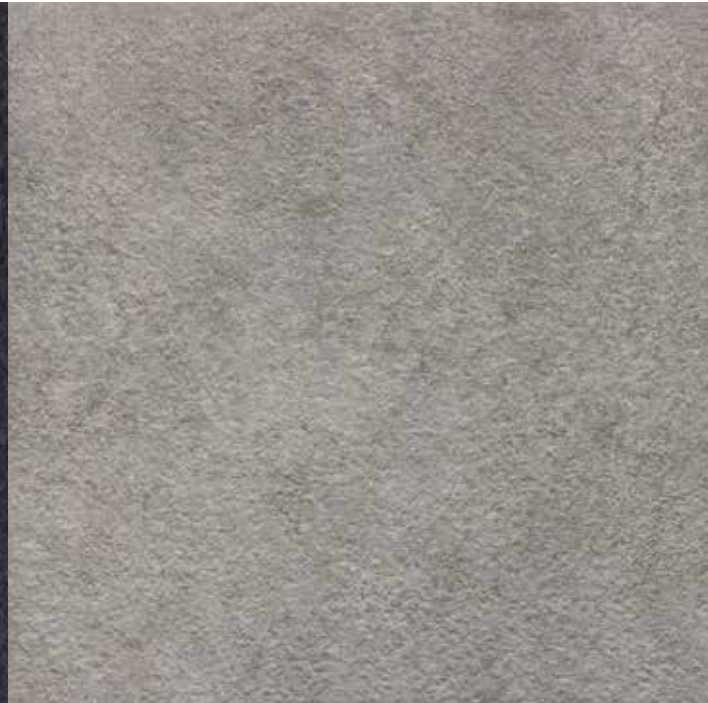

beige



avorio

FORMATI SIZES FORMATS FORMATE

kerblock
PIETRE NATIVE

Formati Sizes
Formats Formate

Superfici Surfaces
Surfaces Oberflächen

Spessori Thicknesses
Epaisseurs Stärken

- NaturaleMatt Naturelle Matt **R11 A+B+C**



cm 60x60
23⁵/₈"x23⁵/₈"



mm 20



Leggera
Subtle
Légère
Leicht

Caratteristiche tecniche e imballi a pagina
Technical features and packing on page
Caractéristiques techniques et emballages à la page
Technische Eigenschaften und Verpackungen auf Seite
448

PEZZI SPECIALI TRIMS ACCESSOIRES FORMSTÜCKE

Art. 9640 Bordo
cm 30x60 - 11³/₄"x23⁵/₈"



Art. 9642 Bordo angolare esterno
cm 30x60 - 11³/₄"x23⁵/₈"

2pcs  45°



Art. 9641 Bordo angolare interno
cm 30x60 - 11³/₄"x23⁵/₈"

2pcs  45°



piombo cm 60x60 - 23⁵/₈"x23⁵/₈"

natural slate black

natural slate

GRANITOGRES

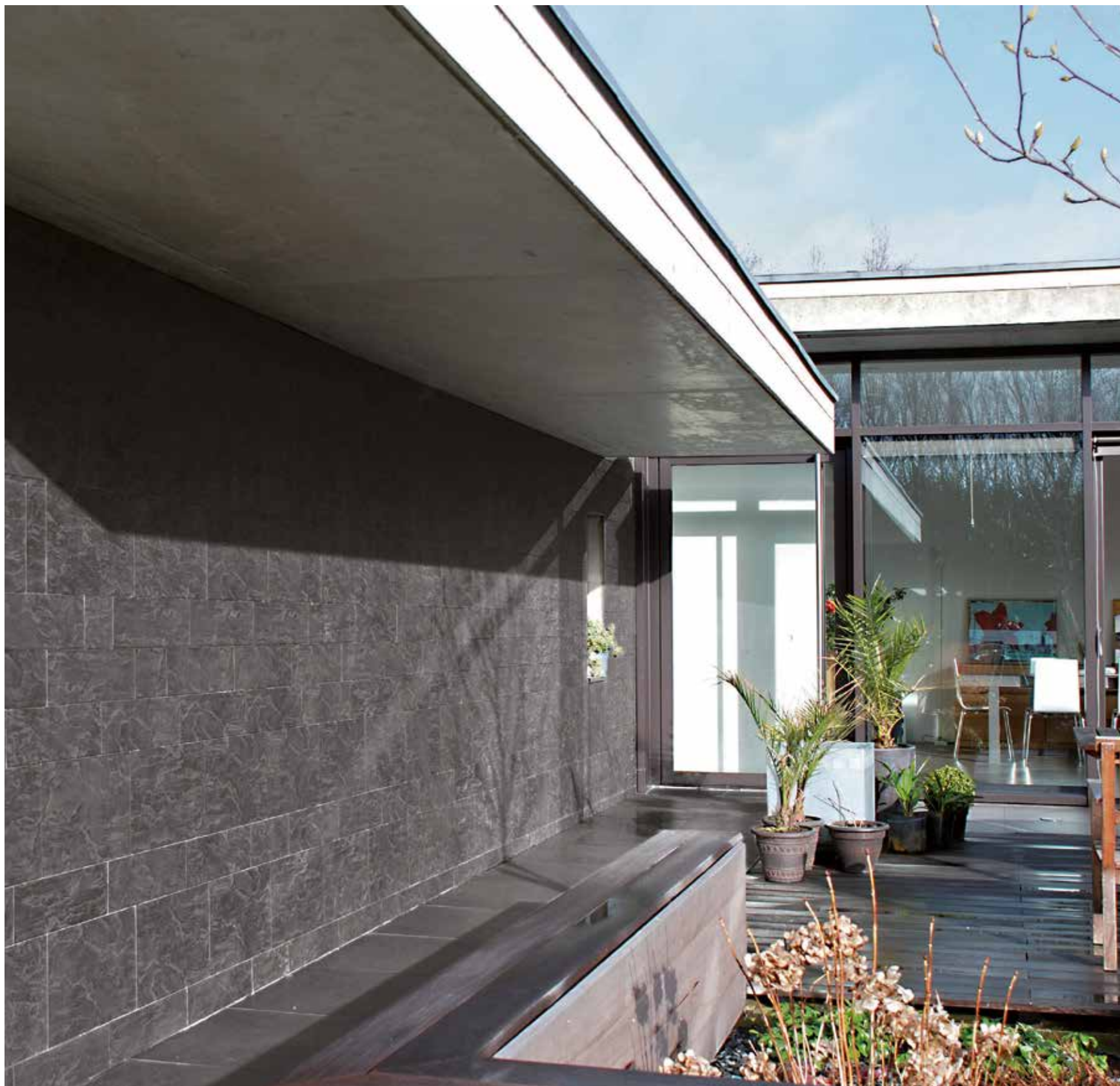

slate black cm 15x30 - 5⁷/₈"x11³/₄", 15x45 - 5⁷/₈"x17³/₄", 30x45 - 11³/₄"x17³/₄"

COLORI COLOURS COULEURS FARBEN

slate black



slate green



slate grey



slate red





slate gold



slate beige

FORMATI SIZES FORMATS FORMATE

natural slate
GRANITOGRES

Formati Sizes Formats Formate	 cm 15x15 5 ⁷ / ₈ "x5 ⁷ / ₈ "	 cm 15x30 5 ⁷ / ₈ "x11 ³ / ₄ "	 cm 30x30 11 ³ / ₄ "x11 ³ / ₄ "
Superfici Surfaces Surfaces Oberflächen	●	●	●
Spessori Thicknesses Epaisseurs Stärken	mm 9	mm 9	mm 9 mm 9*

- Naturale Matt Naturelle Matt **R10 A+B**

* Non rettificato. Unrectified. Non rectifié. Nicht kalibriert.

Le piastrelle della serie Natural Slate, sono fornite in spessore 9 mm, rettificate e modulari (fuga 4 mm).
The tiles in the Natural Slate series are 9 mm thick, ground and modular (4 mm joint).
Les carreaux de la série Natural Slate, sont fournis en épaisseur 9 mm, rectifiés et modulaires (joint 4 mm).
Die Fliesen der Serie Natural Slate werden in der Stärke 9 mm kalibriert und modulär (4 mm Fuge) geliefert.



Media
Medium
Moyenne
Mittel

Caratteristiche tecniche e imballi a pagina
Technical features and packing on page
Caractéristiques techniques et emballages à la page
Technische Eigenschaften und Verpackungen auf Seite
444

DECORI DECORS DÉCORS DEKORE

decoro natural slate*



cm 11x11 - 4³/₈"x4³/₈"

* I decori sono disponibili in scatole assortite.
The boxes contain mixed decorations.
Les décors sont disponibles par boîtes.
Die Dekore sind gemischt in Karton verpackt.

PEZZI SPECIALI TRIMS ACCESSOIRES FORMSTÜCKE

Battiscopa Bullnose
Plinthe à bord arrondi Stehsockel
cm 9x30 - 3¹/₂"x11³/₄"



Gradino Step tread
Nez de marche Stufenplatte
cm 30x30 - 11³/₄"x11³/₄"



Terminale
Pezzo unico Single piece
Une seule pièce Einzelstück
cm 15x30x3,5 - 5⁷/₈"x11³/₄"x1³/₈"

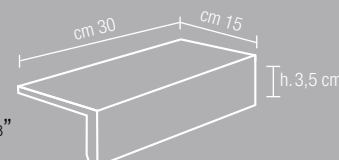

pietre runiche odino

pietre runiche

GRANITOGRES

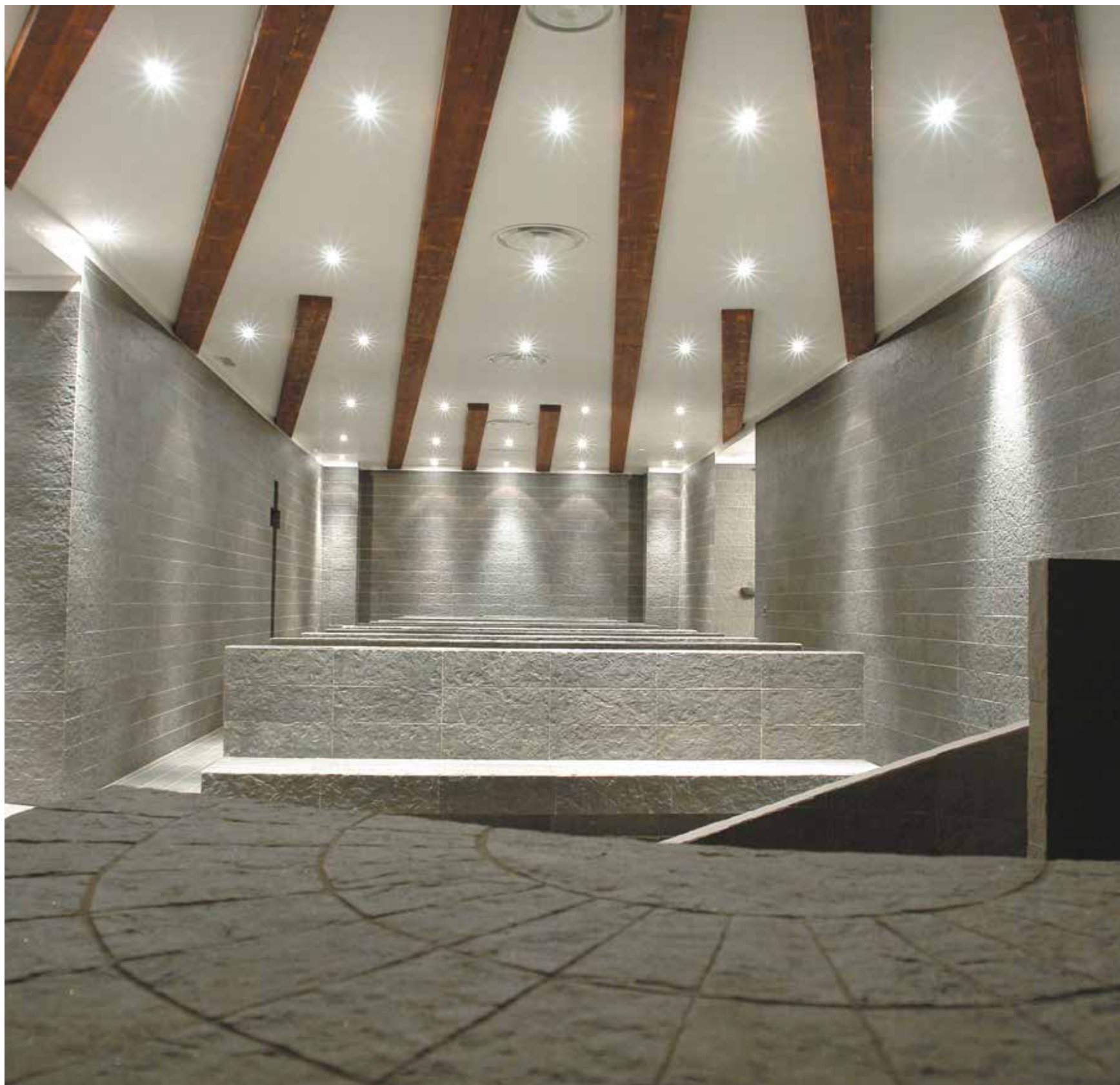

thor, odino cm 15x45 - 5⁷/₈"x17³/₄"

odino



thor



balder



freyr





mondo

FORMATI SIZES FORMATS FORMATE

pietre runiche

GRANITOGRES

Formati Sizes Formats Formate	 cm 15x15 57/8"x57/8"	 cm 15x30 57/8"x113/4"	 cm 30x30 113/4"x113/4"
Superfici Surfaces Surfaces Oberflächen	●	●	●
Spessori Thicknesses Epaisseurs Stärken	mm 9	mm 9	mm 9 mm 9*

- Naturale Matt Naturelle Matt **R11 A+B+C**

* Non rettificato. Unrectified. Non rectifié. Nicht kalibriert.

Le piastrelle della serie Pietre Runiche, sono fornite in spessore 9 mm, rettificate e modulari (fuga 4 mm).

The tiles in the Pietre Runiche series are 9 mm thick, ground and modular (4 mm joint).

Les carreaux de la série Pietre Runiche, sont fournis en épaisseur 9 mm, rectifiés et modulaires (joint 4 mm).

Die Fliesen der Serie Pietre Runiche werden in der Stärke 9 mm kalibriert und modular (4 mm Fuge) geliefert.



Media
Medium
Moyenne
Mittel

Caratteristiche tecniche e imballi a pagina

Technical features and packing on page

Caractéristiques techniques et emballages à la page

Technische Eigenschaften und Verpackungen auf Seite

444



PEZZI SPECIALI TRIMS ACCESSOIRES FORMSTÜCKE

Battiscopa Bullnose
Plinthe à bord arrondi Stehsockel
cm 9x30 - 31/2"x113/4"



Gradino Step tread
Nez de marche Stufenplatte
cm 30x30 - 113/4"x113/4"



Terminale
Pezzo unico Single piece
Une seule pièce Einzelstück
cm 15x30x3,5 - 57/8"x113/4"x13/8"

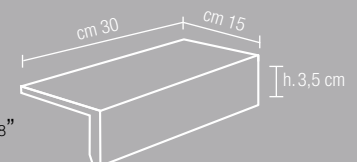

titano chambrod

titano
GRANITOGRES



chambrod *bocciardata* cm 30x60 - 11³/₄"x23⁵/₈", 60x60 - 23⁵/₈"x23⁵/₈"

COLORI COLOURS COULEURS FARBEN

matraia



cardoso



chambrod



grigio ash



buxy



caen

SUPERFICI SURFACES
SURFACES OBERFLÄCHEN

titano
GRANITOGRES

levigata polished polie poliert





naturale matt naturelle matt R9

bocciardata bocciardata bouchardée gehämmert R11 A+B



champagne

FORMATI SIZES FORMATS FORMATE

Formati Sizes Formats Formate		
	cm 30x60 11 ³ / ₄ "x23 ⁵ / ₈ "	cm 60x60 23 ⁵ / ₈ "x23 ⁵ / ₈ "
Superfici Surfaces Surfaces Oberflächen		
Spessori* Thicknesses* Épaisseurs* Stärken*	mm 10,5	mm 10,5
<ul style="list-style-type: none"> ● Naturale Matt Naturelle Matt R9 ● Levigata Polished Polie Poliert ● Bocciardata R11 A+B <p>* Spessore su superficie naturale. Thickness on matt surface. Épaisseur sur surface mat. Stärke der Fliesen mit Mattoberfläche.</p>	 <p>Media Medium Moyenne Mittel</p>	<p>Caratteristiche tecniche e imballi a pagina Technical features and packing on page Caractéristiques techniques et emballages à la page Technische Eigenschaften und Verpackungen auf Seite 444</p>

PEZZI SPECIALI TRIMS ACCESSOIRES FORMSTÜCKE

Battiscopa Bullnose
Plinthe à bord arrondi Stehsockel
cm 9x60 - 3¹/₂"x23⁵/₈"



Gradino Step tread
Nez de marche Stufenplatte
cm 30x60 - 11³/₄"x23⁵/₈"



Gradone (assemblato)
cm 30x33 - 11³/₄"x 13"

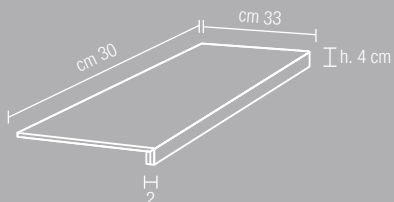

Angolare (assemblato)
cm 30x33 - 11³/₄"x 13"

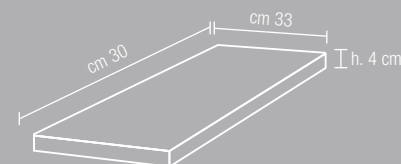

Terminale Pezzo incollato
Glued piece
Pièce collee
Geklebter Stück
cm 15x30x5 - 5⁷/₈"x11³/₄"x2"

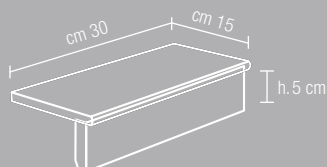

DECORI DECORS DÉCORS DEKORE

fascia C*

cm 30x60 - 11³/₄"x23⁵/₈"

* Naturale, bocciardata. Disponibile in tutti i colori della serie.
 Matt, bocciardata. Available in all the colours of the series.
 Naturel, bouchardée. Disponible dans toutes les couleurs de la série.
 Matt, gehämmert. Verfügbar in allen Farben.

fascia matraia C, matraia levigata cm 30x60 - 11³/₄"x23⁵/₈"

titano
GRANITOGRES

matraia bocciardata cm 60x60 - 23⁵/₈"x23⁵/₈"

ardesia nero

ardesia
GRANITOGRES

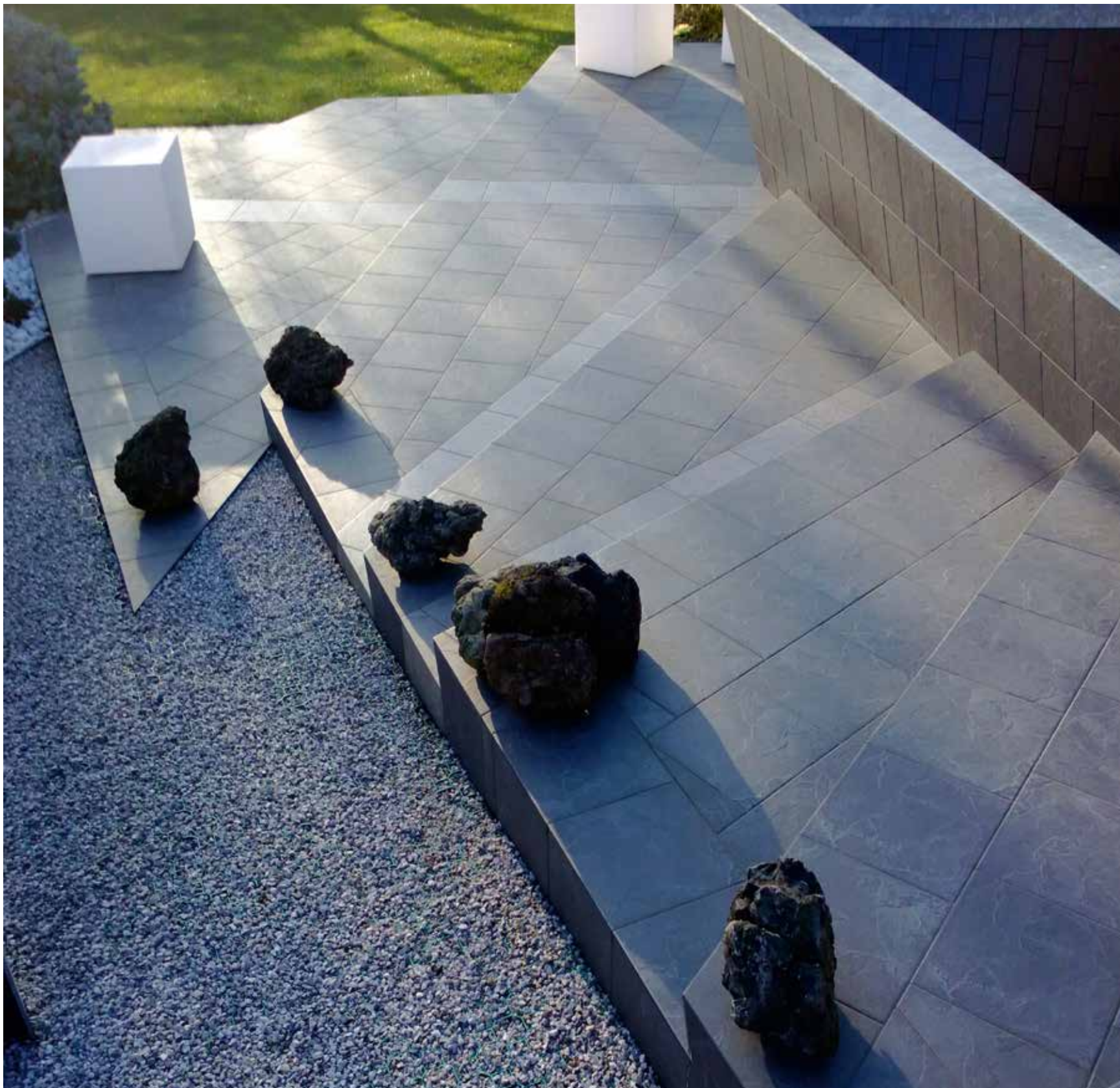

nero, grigio, bianco cm 30x30 - 11³/₄"x11³/₄"

COLORI COLOURS COULEURS FARBEN

nero



grigio



bianco



rosso





rosa



beige

FORMATI SIZES FORMATS FORMATE

ardesia
GRANITOGRES

Formati Sizes Formats Formate	 cm 15x15 5 ⁷ / ₈ "x5 ⁷ / ₈ "	 cm 15x30 5 ⁷ / ₈ "x11 ³ / ₄ "	 cm 30x30 11 ³ / ₄ "x11 ³ / ₄ "
Superfici Surfaces Surfaces Oberflächen	●	●	●
Spessori Thicknesses Epaisseurs Stärken Epaisseurs Stärken	mm 8	mm 8	mm 8,2

- Naturale Matt Naturelle Matt **R10 A+B**

Caratteristiche tecniche e imballi a pagina
Technical features and packing on page
Caractéristiques techniques et emballages à la page
Technische Eigenschaften und Verpackungen auf Seite
444



PEZZI SPECIALI TRIMS ACCESSOIRES FORMSTÜCKE

Battiscopa Bullnose
Plinthe à bord arrondi Stehsockel
cm 9x30 - 3¹/₂"x11³/₄"



Gradino Step tread
Nez de marche Stufenplatte
cm 30x30 - 11³/₄"x11³/₄"



Terminale Pezzo unico pressato
Pièce unique pressée
Pressed single piece
Gepresstes Einzelstück
cm 15x30x3,5 - 5⁷/₈"x11³/₄"x1³/₈"

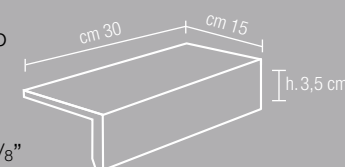

Gradone
e gradone angolare rusticato
cm 30x30 - 11³/₄"x11³/₄"

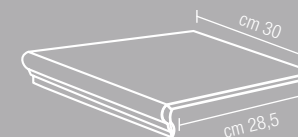

lavagna nera

lavagna
PIETRE NATIVE

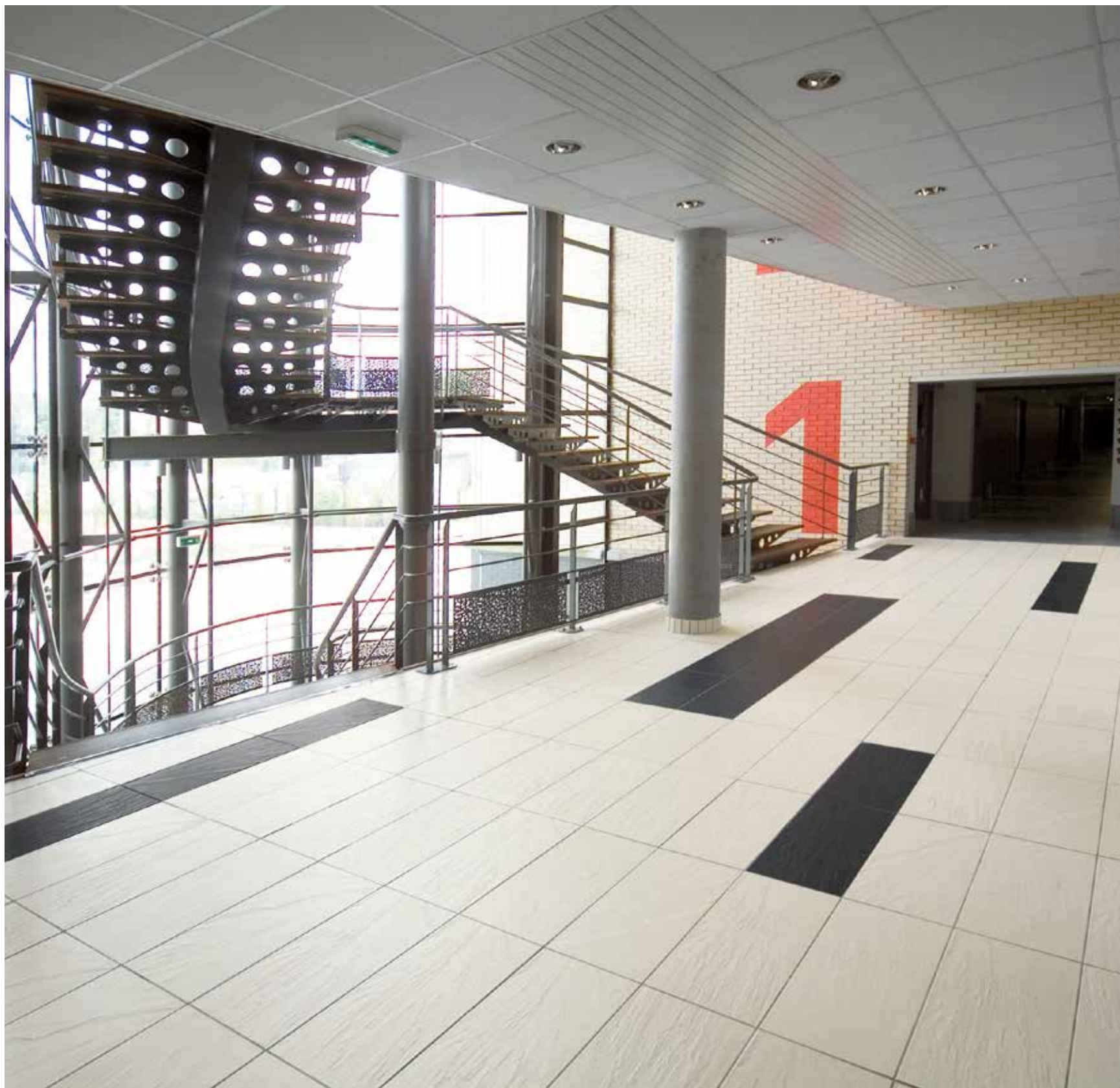

nera, bianca cm 30x60 - 11³/₄"x23⁵/₈"

COLORI COLOURS COULEURS FARBEN

nera







grigia



bianca

FORMATI SIZES FORMATS FORMATE

lavagna
PIETRE NATIVE

Formati Sizes Formats Formate	 cm 15x15 5 ⁷ / ₈ "x5 ⁷ / ₈ "	 cm 30x30 11 ³ / ₄ "x11 ³ / ₄ "	 cm 30x60 11 ³ / ₄ "x23 ⁵ / ₈ "	 cm 60x60* 23 ⁵ / ₈ "x23 ⁵ / ₈ "
Superfici Surfaces Surfaces Oberflächen	●	●	●	●
Spessori Thicknesses Épaisseurs Stärken	mm 9,4	mm 9,4	mm 10,5 mm 9,4	mm 10,5
● Naturale Matt Naturelle Matt R10A			 Leggera Subtile Légère Leicht	Caratteristiche tecniche e imballi a pagina Technical features and packing on page Caractéristiques techniques et emballages à la page Technische Eigenschaften und Verpackungen auf Seite 448
* Solo Lavagna nera Only Lavagna nera Seulement Lavagna nera Nur Lavagna nera				

Rettificate in un unico calibro. Single caliber, rectified version.
Rectifiés en un unique calibre. Einem einzigen Werkmass maßgeschliffen geliefert.

Nel caso di combinazioni di formati di spessori diversi, specificarlo espressamente nell'ordine.
Please specify in your order if you wish to purchase formats including more than one thickness.
Prière de spécifier dans votre commande si vous souhaitez acheter des formats avec différentes épaisseurs.
Bitte weisen Sie im Bestellungsformular ausdrücklich darauf hin, wenn Sie Formatkombinationen mit verschiedenen Stärken wünschen.

PEZZI SPECIALI TRIMS ACCESSOIRES FORMSTÜCKE

Battiscopa Bullnose
Plinthe à bord arrondi Stehsockel
cm 9x30 - 3¹/₂"x11³/₄"
cm 9x60 - 3¹/₂"x23⁵/₈"



Gradino Step tread
Nez de marche Stufenplatte
cm 30x30 - 11³/₄"x11³/₄"
cm 30x60 - 11³/₄"x23⁵/₈"

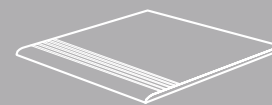

Tozzetto Insert
Caboçon Einleger
cm 9x9 - 3¹/₂"x 3¹/₂"



Listello Listel
Listel Zeierleiste
cm 9x30 - 3¹/₂"x11³/₄"



Terminale Pezzo incollato
Glued piece
Pièce collee
Geklebter Stück
cm 15x30x5 - 5⁷/₈"x11³/₄"x2"

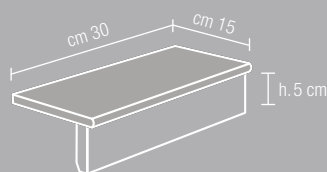

Scalino
e scalino angolare
cm 30x33 - 11³/₄"x13"

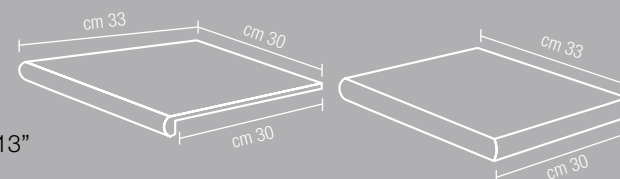

patio grey

patio
GRESPLUS

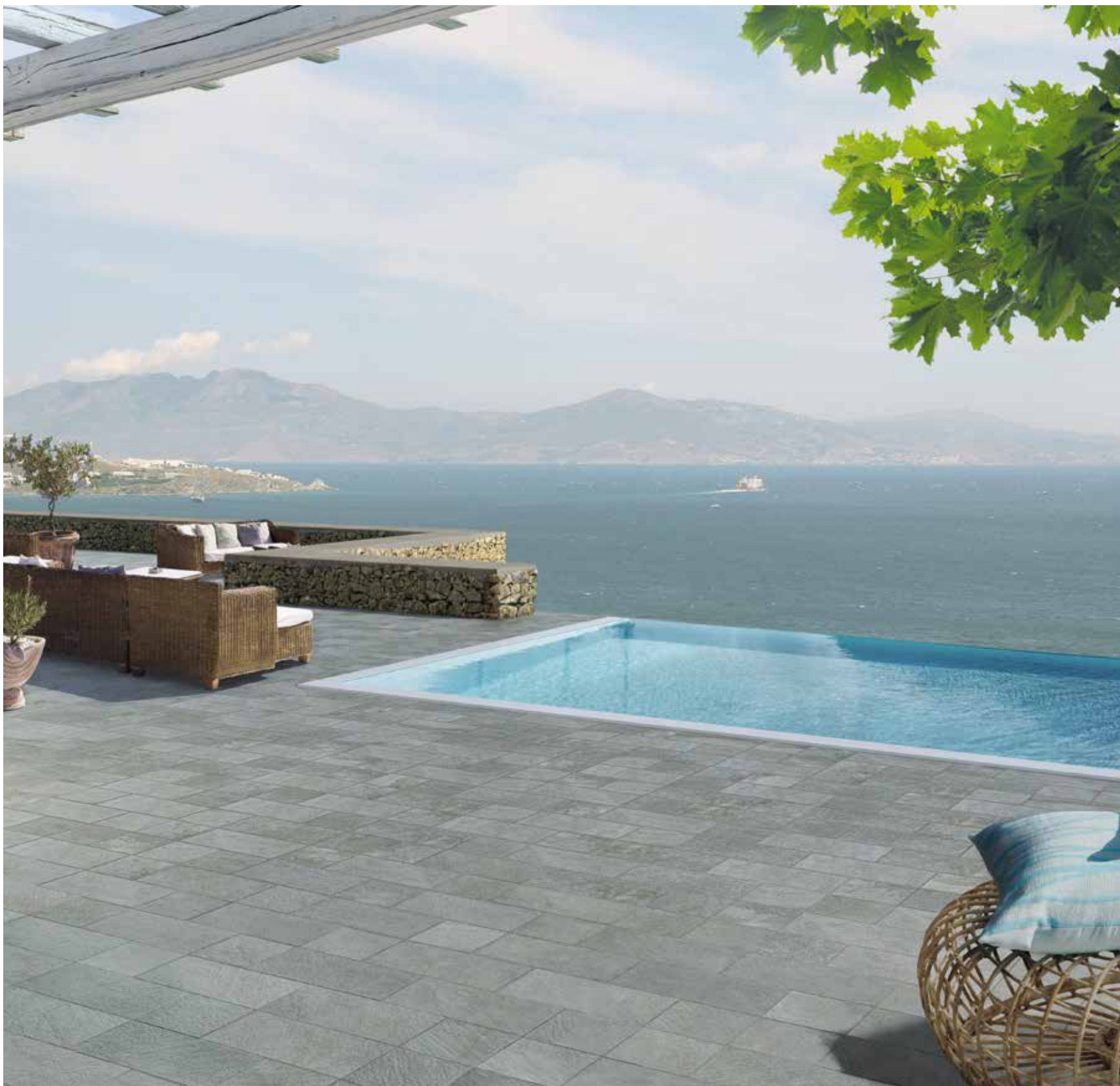

grey cm 20x20 - 7⁷/₈"x7⁷/₈", 20x40 - 7⁷/₈"x15³/₄"

COLORI COLOURS COULEURS FARBEN

black

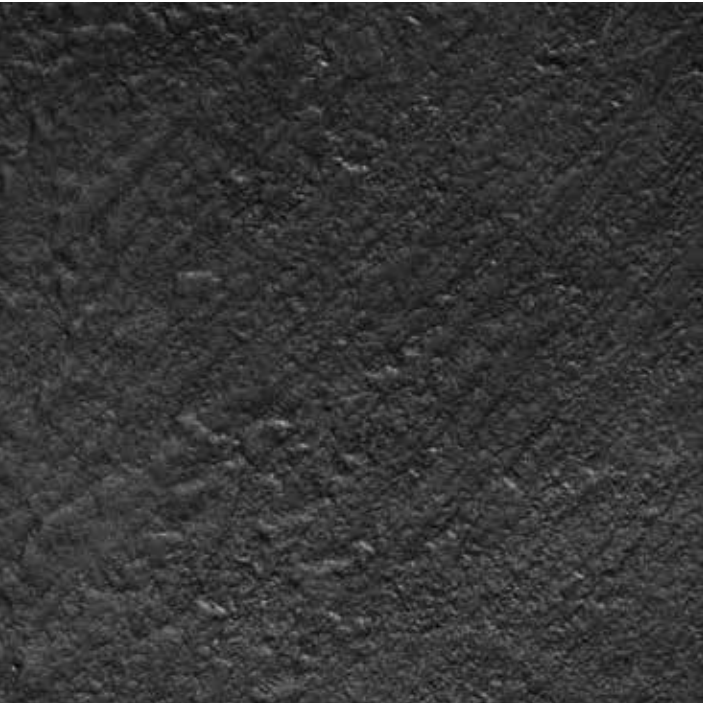

grey



white



brown



gold



beige

FORMATI SIZES FORMATS FORMATE

patio
GRESPLUS

Formati Sizes
Formats Formate



cm 20x20
7⁷/₈"x7⁷/₈"



cm 20x40
7⁷/₈"x15³/₄"

Superfici Surfaces
Surfaces Oberflächen



Spessori Thicknesses
Epaisseurs Stärken

mm 8,3

mm 8,3

- Naturale Matt Naturelle Matt **R11 A+B**



Accentuata
Accentuated
Forte
Akzentuiert

Caratteristiche tecniche e imballi a pagina
Technical features and packing on page
Caractéristiques techniques et emballages à la page
Technische Eigenschaften und Verpackungen auf Seite
452



gold cm 20x40 - 7⁷/₈"x15³/₄"

PEZZI SPECIALI TRIMS ACCESSOIRES FORMSTÜCKE

Battiscopa Bullnose
Plinthe à bord arrondi Stehsockel
cm 8x40 - 3¹/₈"x15³/₄"



Terminale Pezzo unico pressato
Pièce unique pressée
Pressed single piece
Gepresstes Einzelstück
cm 15x30x3,5 - 5⁷/₈"x11³/₄"x1³/₈"

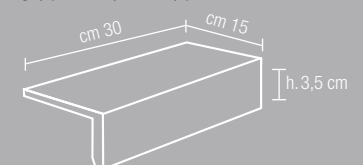

agorà megalopoli

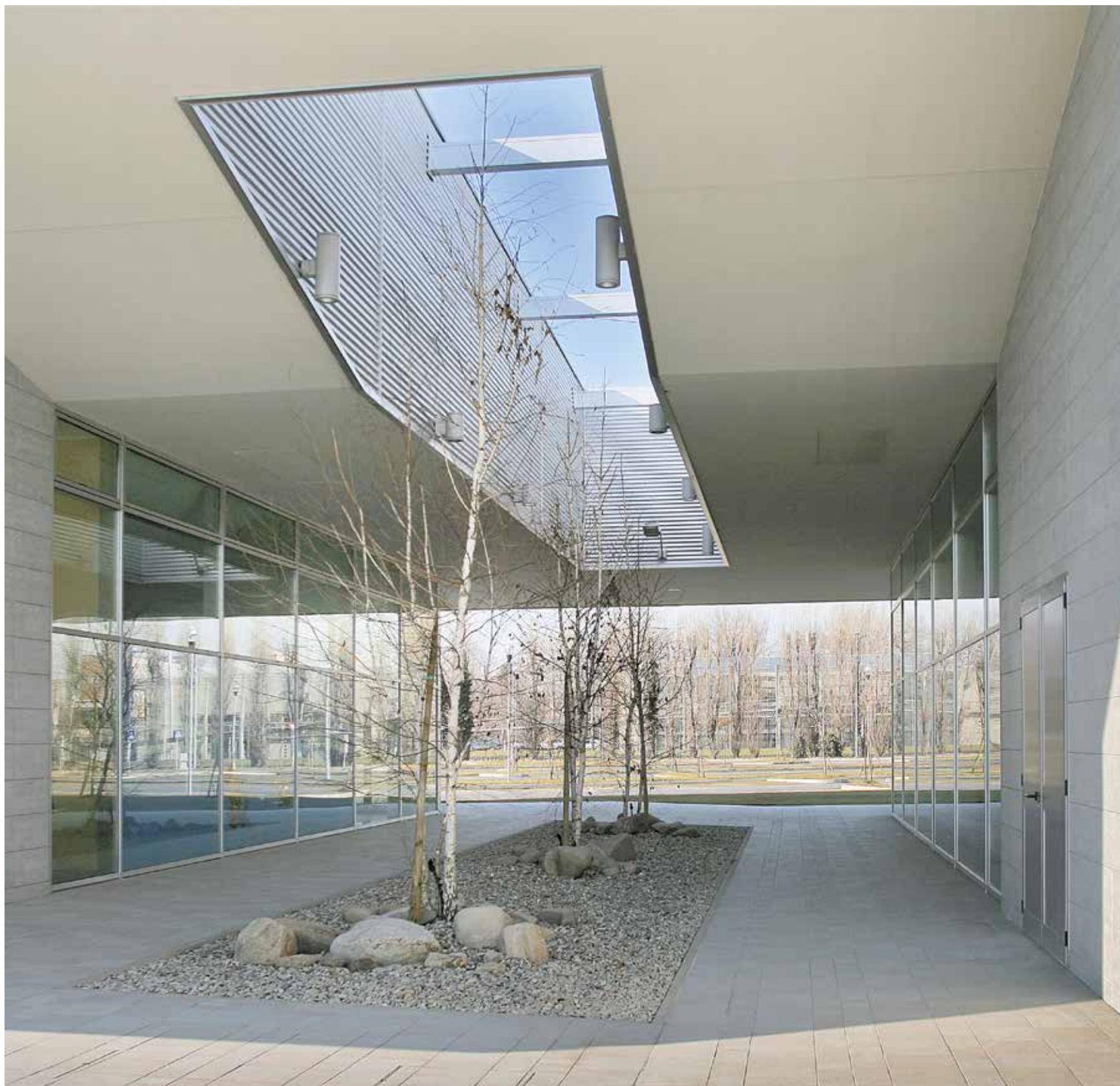

sparta, corinto cm 15x15 - 5⁷/₈"x5⁷/₈", 15x30 - 5⁷/₈"x11³/₄", 30x30 - 11³/₄"x11³/₄"

COLORI COLOURS COULEURS FARBEN

elatea

megalopoli

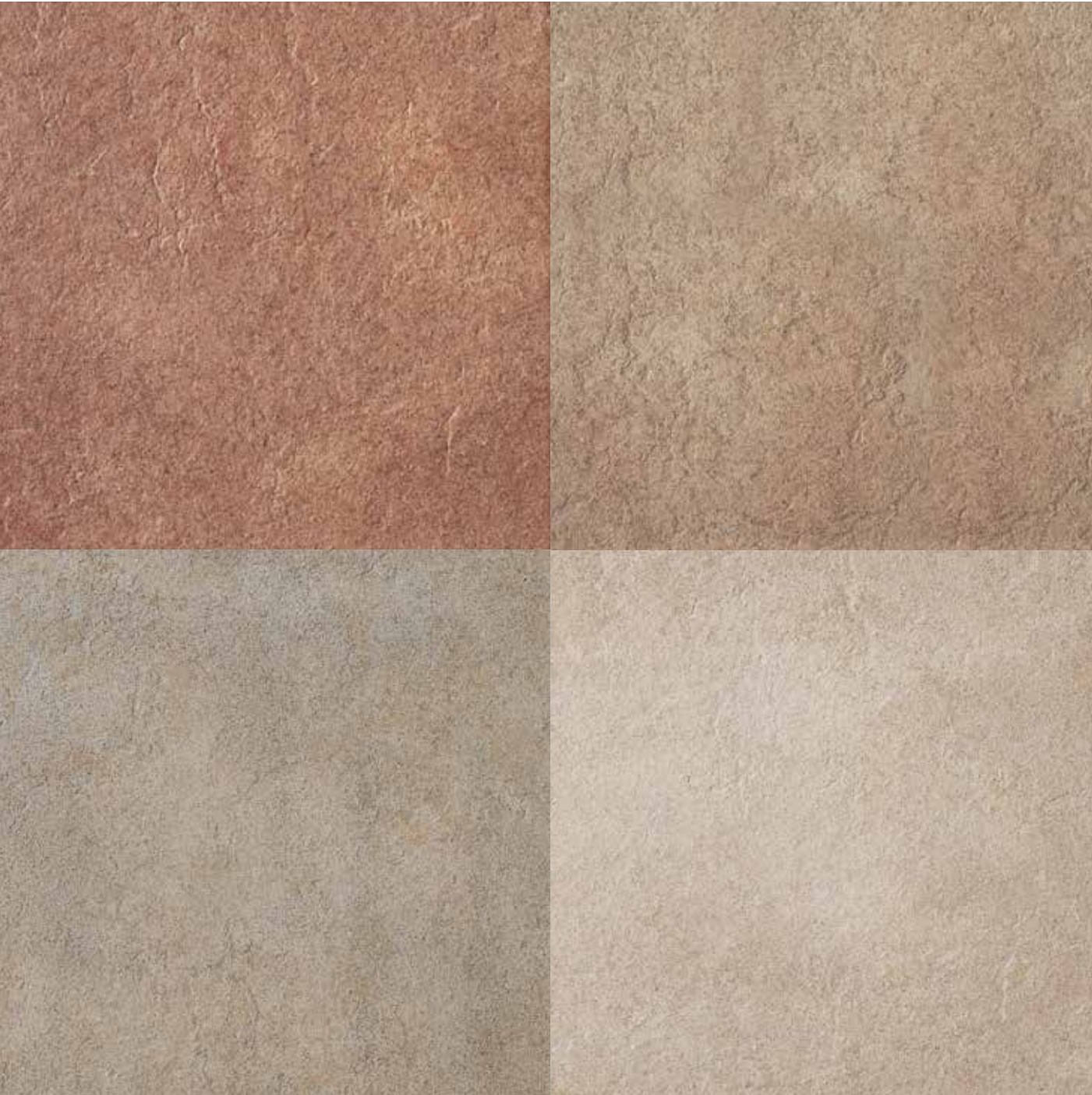



corinto

sparta

FORMATI SIZES FORMATS FORMATE

agorà
GRANITOGRES

Formati Sizes Formats Formate	 cm 15x15 5 ⁷ / ₈ "x5 ⁷ / ₈ "	 cm 15x30 5 ⁷ / ₈ "x11 ³ / ₄ "	 cm 30x30 11 ³ / ₄ "x11 ³ / ₄ "
Superfici Surfaces Surfaces Oberflächen	●	●	●
Spessori Thicknesses Epaisseurs Stärken	mm 8	mm 8	mm 8,2

- Naturale Matt Naturelle Matt **R11 A+B**

Caratteristiche tecniche e imballi a pagina
Technical features and packing on page
Caractéristiques techniques et emballages à la page
Technische Eigenschaften und Verpackungen auf Seite
444



sparta, corinto cm 15x15 - 5⁷/₈"x5⁷/₈", 15x30
5⁷/₈"x11³/₄", 30x30 - 11³/₄"x11³/₄"

PEZZI SPECIALI TRIMS ACCESSOIRES FORMSTÜCKE

Battiscopa Bullnose
Plinthe à bord arrondi Stehsockel
cm 9x30 - 3¹/₂"x11³/₄"



Terminale Pezzo unico pressato
Pièce unique pressée
Pressed single piece
Gepresstes Einzelstück
cm 15x30x3,5 - 5⁷/₈"x11³/₄"x1³/₈"

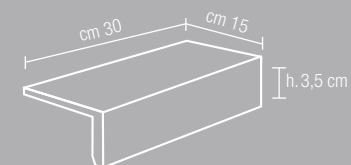

Gradino Step tread
Nez de marche Stufenplatte
cm 30x30 - 11³/₄"x11³/₄"



rocks alpi

rocks
GRESPLUS



alpi cm 30x30 - 11³/₄"x11³/₄"

COLORI COLOURS COULEURS FARBEN

alpi



atlante





ande



himalaya

FORMATI SIZES FORMATS FORMATE

rocks
GRESPLUS

Formati Sizes Formats Formate	 cm 15x30 5 ⁷ / ₈ "x11 ³ / ₄ "	 cm 30x30 11 ³ / ₄ "x11 ³ / ₄ "
Alpi G4*	●	●
Ande G4*	●	●
Atlante G4*	●	●
Himalaya G4*	●	●
Spessori Thicknesses Epaisseurs Stärken	mm 8	mm 8,2
● Naturale Matt Naturelle Matt R10 A+B	 Caratteristiche tecniche e imballi a pagina Technical features and packing on page Caractéristiques techniques et emballages à la page Technische Eigenschaften und Verpackungen auf Seite 452	
* Vedi pagina See page Voir page Siehe Seite 453		



PEZZI SPECIALI TRIMS ACCESSOIRES FORMSTÜCKE

Battiscopa Bullnose
Plinthe à bord arrondi **Stehsokkel**
cm 8x30 - 3¹/₂"x11³/₄"



Terminale Pezzo unico pressato
Pièce unique pressée
Pressed single piece
Gepresstes Einzelstück
cm 15x30x3,5 - 5⁷/₈"x11³/₄"x1³/₈"

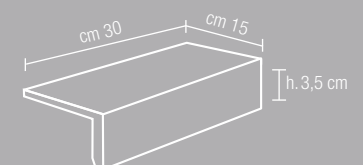

Gradino Step tread
Nez de marche **Stufenplatte**
cm 30x30 - 11³/₄"x11³/₄"



palatino domiziano

palatino
GRESPLUS

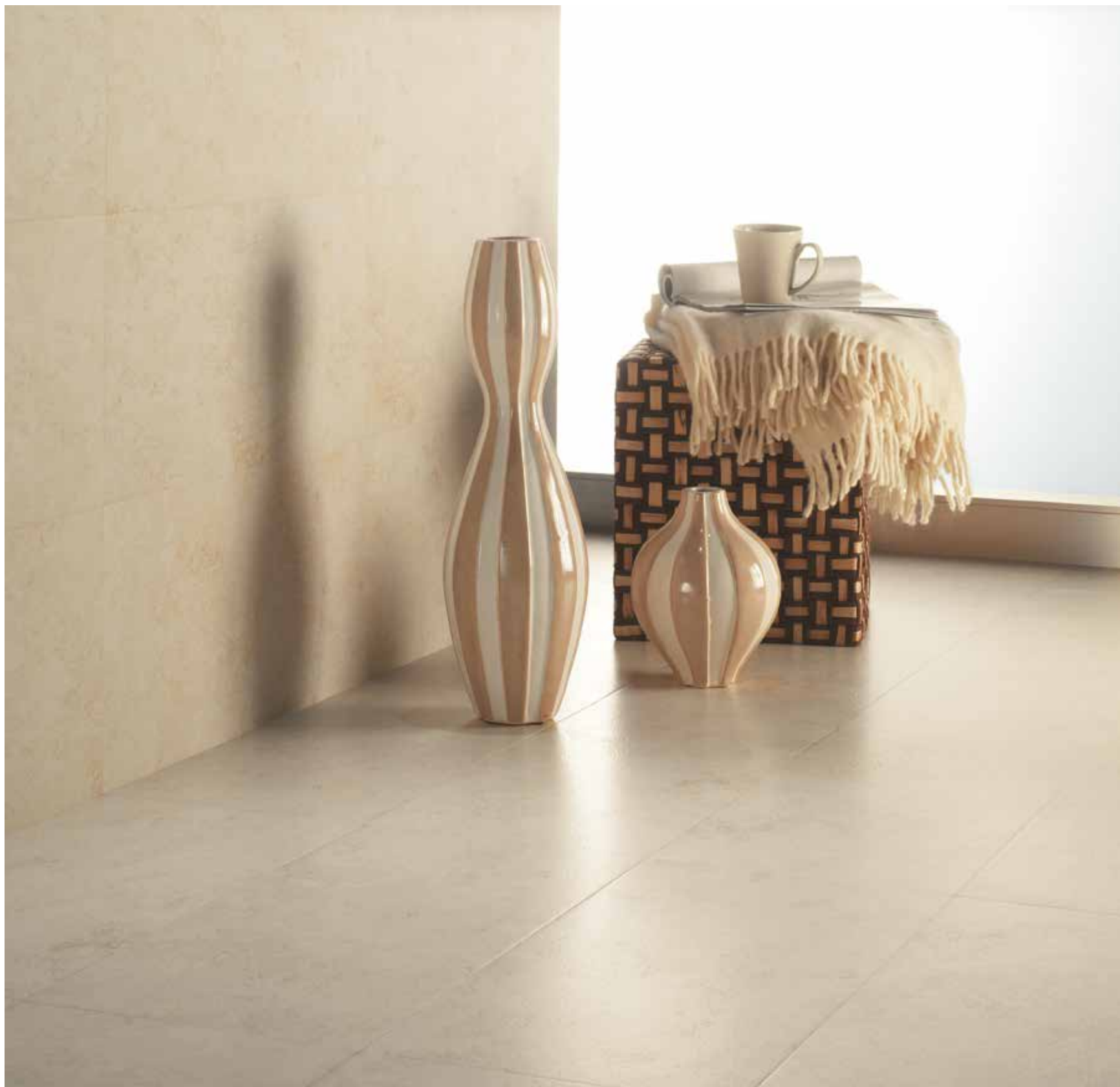

domiziano cm 30x60 - 11³/₄"x23⁵/₈"

COLORI COLOURS COULEURS FARBEN

claudio



tiberio



adriano





caligola



domiziano

FORMATI SIZES FORMATS FORMATE

palatino
GRESPLUS

Formati Sizes Formats Formate	 cm 30x30 11 ³ / ₄ "x11 ³ / ₄ "	 cm 45x45 17 ³ / ₄ "x17 ³ / ₄ "	 cm 30x60 11 ³ / ₄ "x23 ⁵ / ₈ "
Adriano G4*	●	●	●
Caligola G4*	●	●	●
Claudio G4*	●	●	●
Domiziano G4*	●	●	●
Tiberio G4*	●	●	●
Spessori Thicknesses Epaisseurs Stärken	mm 8,9	mm 9	mm 9

● Naturale Matt Naturelle Matt

* Vedi pagina See page Voir page Siehe Seite
453

Caratteristiche tecniche e imballi a pagina
Technical features and packing on page
Caractéristiques techniques et emballages à la page
Technische Eigenschaften und Verpackungen auf Seite
452

Su richiesta, le piastrelle della Serie Palatino, possono essere fornite squadrate e rettificate in modo da consentire la posa senza fuga. Tale richiesta deve essere espressamente indicata nell'ordine.
On request, Palatino Series tiles can be supplied squared and ground so that they can be fixed without gaps. This must be explicitly indicated in the order.
Sur demande, les carreaux de la série Palatino peuvent être fournis équarris et rectifiés de manière à permettre la pose sans joint. Cette demande doit être indiquée expressément dans la commande.
Auf Wunsch können die Fliesen der Serie Palatino zugeschnitten und geschliffen geliefert werden, damit die Verlegung ohne Fuge möglich ist. Dieser Wunsch ist ausdrücklich auf dem Auftrag anzugeben.



PEZZI SPECIALI TRIMS ACCESSOIRES FORMSTÜCKE

Battiscopa Bullnose
Plinthe à bord arrondi Stehsockel
cm 9x30 - 3¹/₂"x11³/₄"
cm 9x45 - 3¹/₂"x17³/₄"



Gradino Step tread
Nez de marche Stufenplatte
cm 30x30 - 11³/₄"x11³/₄"



DECORI DECORS DÉCORS DEKORE



domiziano cm 30x30 - 11³/₄"x11³/₄"
mosaico domiziano caligola cm 30x30 - 11³/₄"x11³/₄"

palatino

GRESPLUS

**mosaico
claudio, adriano,
domiziano**



cm 30x30 - 11³/₄"x11³/₄"
tessera cm 7,3x7,3 - 3"x3"
su rete on net sur trame auf Netz

**mosaico
domiziano, caligola**



cm 30x30 - 11³/₄"x11³/₄"
tessera cm 7,3x7,3 - 3"x3"
su rete on net sur trame auf Netz

matita adriano*



cm 3x30 - 1/2"x11³/₄"

spigolo matita adriano*



london adriano*



cm 8x30 - 3¹/₄"x11³/₄"

london adriano*



inserto marmo frutta



cm 7,3x7,3 - 3"x3"

* Disponibile in tutti i colori della serie.
Available in all the colours of the series.
Disponibile dans tous les couleurs de la série.
Verfügbar in allen farben.

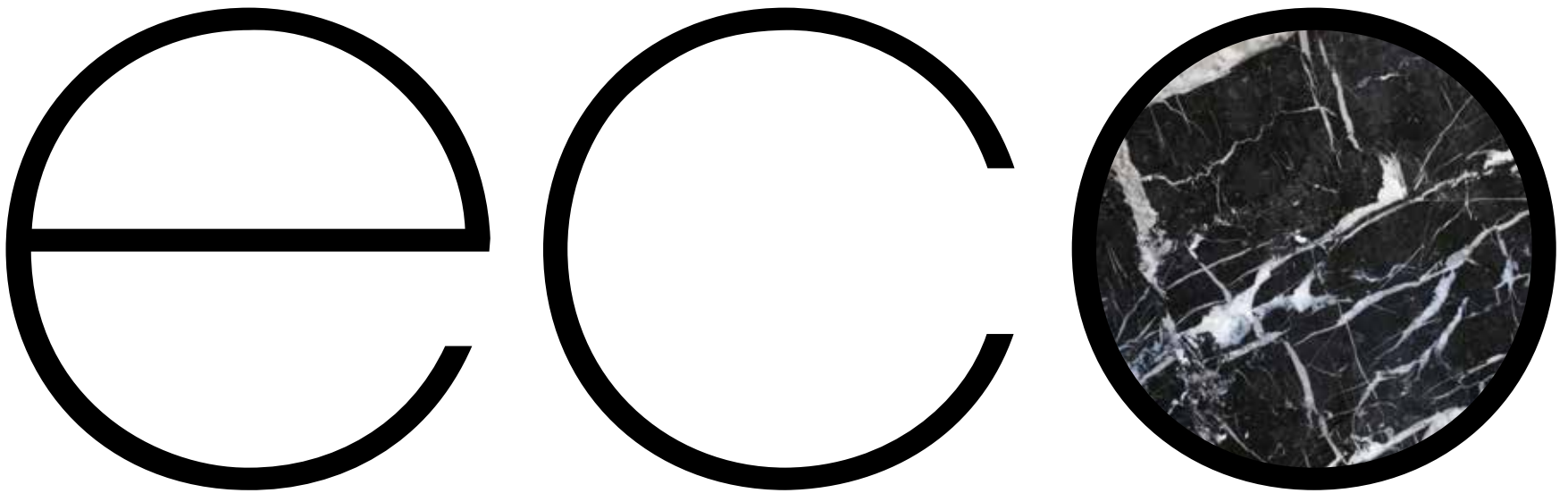

eco**marble** éco**marbre** öko**marmor**

marmo

ecomarmo

184 **marmoker**

208 **marté**

220 **marmogres**

MARMO

Roccia cristallina, da decorazione e costruzione, lucidabile e di natura compatta, prevalentemente costituita da minerale di durezza Mohs da 3 a 4, quali calciti, dolomiti e serpentini. In funzione della sua composizione mineralogica la roccia cristallina può essere sintetizzata in quattro grandi categorie: alla prima appartengono i marmi propriamente detti [ovvero calcari metamorfici ricristallizzati], i calcefiri e i cipollini.

Alla seconda i calcari, le dolomie e le breccie calcaree lucidabili. Alla terza i serpentini. Alla quarta le oficalciti.

MARBLE

Crystalline rock for building and decorative purposes that can be polished. Characterized by a compact nature, it mainly consists of minerals with 3 to 4 Mohs hardness, such as calcites, dolomites and serpentine rocks. Depending on its mineralogical composition, crystalline rock can be roughly divided into four large categories: marbles in the strict sense belong to the first category [i.e. recrystallized metamorphic limestones], along with calciferous and carystium rocks. The second category includes limestones, dolomites and limestone breccia fit for polishing. Serpentine rocks belong to the third category and ophicalcites to the fourth.



marmoker
GRANITOKER



bardiglio imperiale lucida cm 59x118 - 23¹/₄"x46¹/₂"; **mosaico, mosaico 5x10** cm 29,5x29,5 - 11⁵/₈"x11⁵/₈"

COLORI COLOURS COULEURS FARBEN **59x118**

nero creta



pulpis tortora



bardiglio imperiale



olimpo

travertino bianco

asiago

Articoli prodotti nel formato cm 59x118 e sottomultipli.
Items produced in size cm 59x118 size and submultiples.
Articles fabriqués dans le format cm 59x118 et sous-multiples.
Hergestellte Artikel im Format cm 59x118 und Unterformaten.

marmoker
GRANITOKER

breccia argento



zebrino



bardiglio bianco



statuario oro



statuario grigio



canova

COLORI COLOURS COULEURS FARBEN **59x118**

travertino moka



saint laurent



birimbau



giallo striato



travertino romano



travertino miele

Articoli prodotti nel formato cm 59x118 e sottomultipli.
Items produced in size cm 59x118 size and submultiples.
Articles fabriqués dans le format cm 59x118 et sous-multiples.
Hergestellte Artikel im Format cm 59x118 und Unterformaten.

marmoker
GRANITOKER

travertino noce



travertino s. caterina



asiago, crema select *lucida*
cm 59x59 - 23¹/₄"x23¹/₄"



rosato

crema select



rosato *lucida*
cm 59x118 - 23¹/₄"x46¹/₂"

COLORI COLOURS COULEURS FARBEN **90x180**

grigio billiemi



grafite marrone

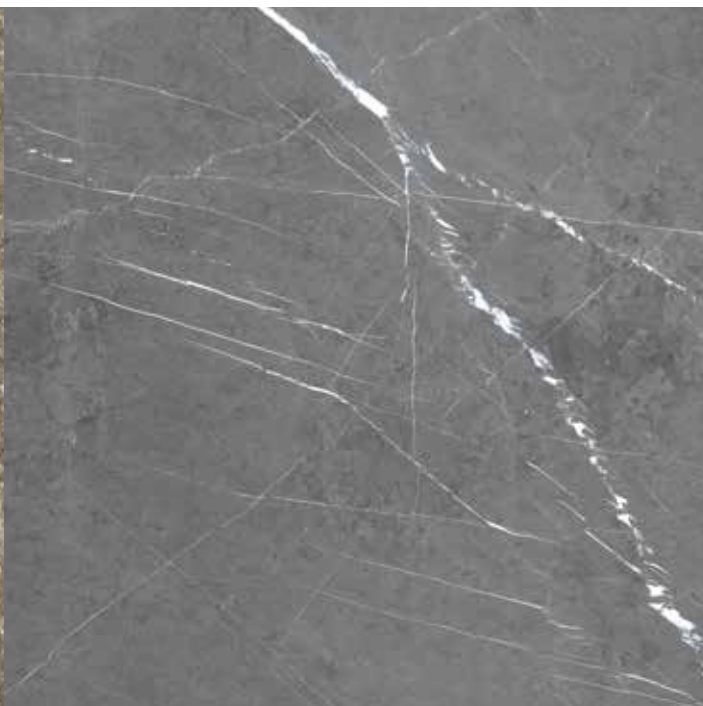

travertino titanium

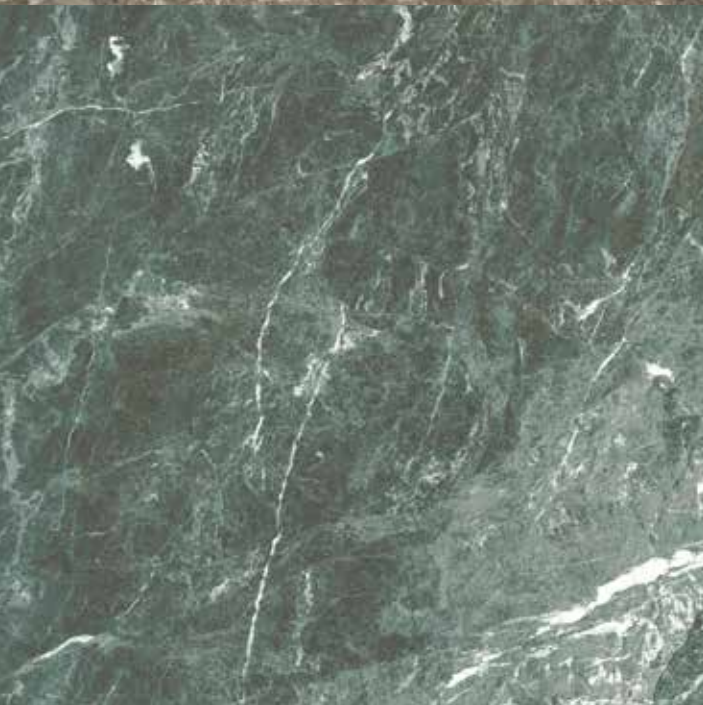

verde aver



breccia carsica



fiorito

Articoli prodotti nel formato cm 90x180 e sottomultipli.
Items produced in size cm 90x180 size and submultiples.
Articles fabriqués dans le format cm 90x180 et sous-multiples.
Hergestellte Artikel im Format cm 90x180 und Unterformaten.

marmoker
GRANITOKER

jolie



arabesque



statuario grigio

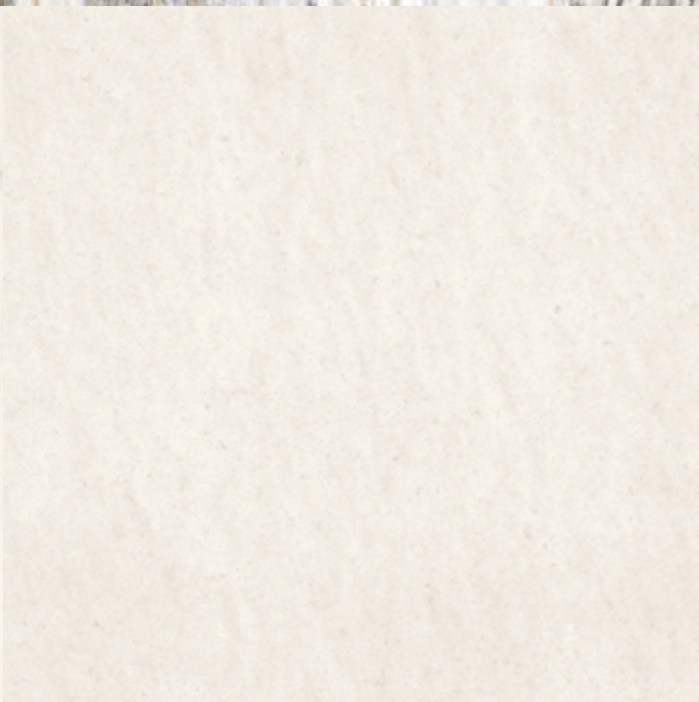

bianco vietnam



statuario grigio, grafite marrone
lucida
cm 90x180 - 35³/₈"x70⁷/₈"

COLORI COLOURS COULEURS FARBEN **90x180**

breccia sarda



silvia oro



veselye

Articoli prodotti nel formato cm 90x180 e sottomultipli.
Items produced in size cm 90x180 size and submultiples.
Articles fabriqués dans le format cm 90x180 et sous-multiples.
Hergestellte Artikel im Format cm 90x180 und Unterformaten.

SUPERFICI SURFACES SURFACES OBERFLÄCHEN

marmoker
GRANITOKER

lucida

naturale matt naturelle matt R9

FORMATI SIZES FORMATS FORMATE

59x118

Formati Sizes
Formats Formatecm 9,8x59
37/8"x23 1/4"cm 29,5x59
11 5/8"x23 1/4"cm 59x59
23 1/4"x23 1/4"cm 29,5x118
11 5/8"x46 1/2"cm 59x118
11 5/8"x46 1/2"

Asiago

Bardiglio Bianco

Bardiglio Imperiale

Birimbau

Breccia Argento

Canova

Crema Select

Giallo Striato

Nero Creta

Olimpo

Pulpis Tortora

Rosato

Saint Laurent

Statuario Grigio

Statuario Oro

Travertino Bianco

Travertino Miele

Travertino Moka

Travertino Noce

Travertino Romano

Travertino Santa Caterina

Zebrino

Spessori Thicknesses
Epaisseurs Stärken

mm 10

mm 10

mm 10

mm 10

mm 10

- Naturale Matt Naturelle Matt **R9**
- Lucida

Le piastrelle della serie Marmoker sono fornite squadrate e rettificate.
The tiles in the Marmoker series come squared and rectified.
Les carreaux de la série Marmoker sont fournis équarris et rectifiés.
Die Fliesen der Serie Marmoker werden rechteckig geschnitten und rektifiziert geliefert.

Caratteristiche tecniche e imballi a pagina
Technical features and packing on page
Caractéristiques techniques et emballages à la page
Technische Eigenschaften und Verpackungen auf Seite
450

PEZZI SPECIALI TRIMS ACCESSOIRES FORMSTÜCKE

Battiscopa Bullnose
Plinthe à bord arrondi
Stehsockel
cm 9x59 - 3 1/2"x23 1/4"

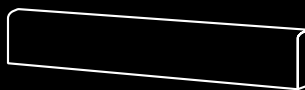

-

Gradino Step tread
Nez de marche
Stufenplatte
cm 29,5x59 - 11 5/8"x23 1/4"



-

Tozzetto Insert
Cabochoon Einleger
cm 9x9 - 3 1/2"x 3 1/2"

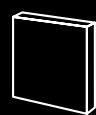

-

Gradone (assemblato)
cm 118x33 - 46 1/2"x 13"

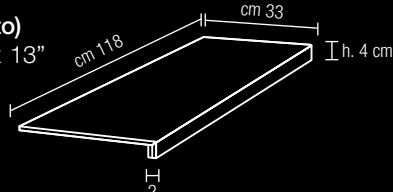

-

Angolare (assemblato)
cm 118x33 - 46 1/2"x 13"

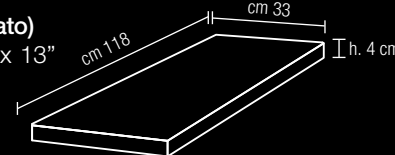

-

Esagono
cm 30x51,9
11 3/4"x20 3/8"

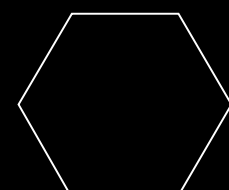



-

FORMATI SIZES FORMATS FORMATE

marmoker
GRANITOKER

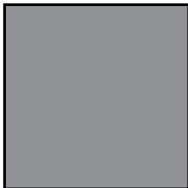
90X180

Formati Sizes Formats Formate			
	cm 45x90 17 ³ / ₄ "x35 ³ / ₈ "	cm 90x90 35 ³ / ₈ "x35 ³ / ₈ "	cm 90x180 35 ³ / ₈ "x70 ⁷ / ₈ "
Grigio Billiemi	● ●	● ●	● ●
Grafite Marrone	● ●	● ●	● ●
Jolie	● ●	● ●	● ●
Arabesque	● ●	● ●	● ●
Verde Aver	● ●	● ●	● ●
Breccia Carsica	● ●	● ●	● ●
Fiorito	● ●	● ●	● ●
Statuario Grigio	● ●	● ●	● ●
Bianco Vietnam	● ●	● ●	● ●
Breccia Sarda	● ●	● ●	● ●
Silvia Oro	● ●	● ●	● ●
Travertino Titanium	● ●	● ●	● ●
Veselye	● ●	● ●	● ●
Spessori Thicknesses Epaisseurs Stärken	mm 10	mm 10	mm 10

- Naturale Matt Naturelle Matt **R9**
- Lucida

Le piastrelle della serie Marmoker sono fornite squadrate e rettificate.
The tiles in the Marmoker series come squared and rectified.
Les carreaux de la série Marmoker sont fournis équarris et rectifiés.
Die Fliesen der Serie Marmoker werden rechteckig geschnitten und rektifiziert geliefert.

Caratteristiche tecniche e imballi a pagina
Technical features and packing on page
Caractéristiques techniques et emballages à la page
Technische Eigenschaften und Verpackungen auf Seite
450

PEZZI SPECIALI TRIMS ACCESSOIRES FORMSTÜCKE

Battiscopa Bullnose
Plinthe à bord arrondi
Stehsockel
cm 9x90 - 3¹/₂"x35³/₈"

- ●



Gradino Step tread
Nez de marche
Stufenplatte
cm 30x90 - 11⁵/₈"x35³/₈"

- ●



Gradone (assemblato)
cm 180x33 - 70⁷/₈"x13"

- ●

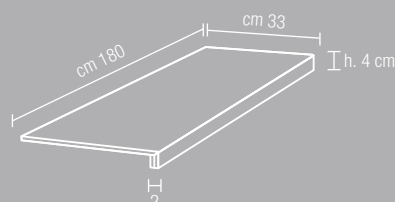

Angolare (assemblato)
cm 180x33 - 70⁷/₈"x13"

- ●

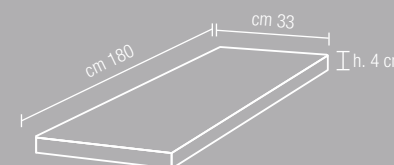



mosaico decoro nero creta *lucida*
cm 29,5x29,5 - 11⁵/₈"x11⁵/₈"
nero creta, statuario grigio *lucida*
cm 59x118 - 23¹/₄"x46¹/₂"



mosaico cascata A *lucida*
cm 29,5x206,5 - 11⁵/₈"x81¹/₄" ,
canova *lucida*
cm 59x59 - 23¹/₄"x23¹/₄"

DECORI DECORS DÉCORS DEKORE

59x118

mosaico cascata A*

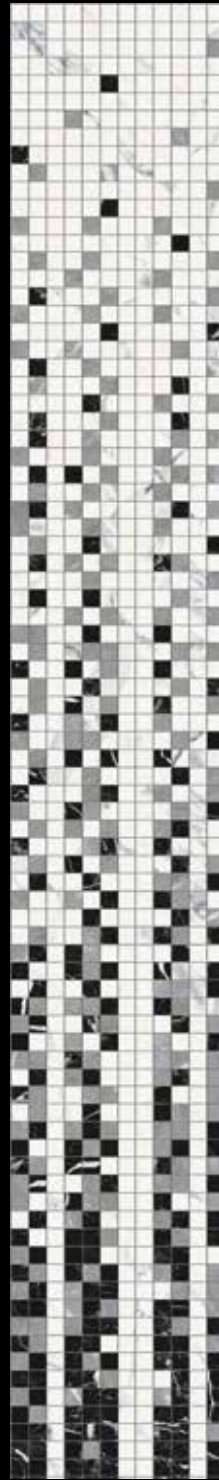

cm 29,5x206,5 - 11⁵/₈"x81¹/₄"
tessera cm 2,3x2,3 - 1"x1"
su rete on net sur trame auf Netz
statuario grigio, nero creta,
bardiglio imperiale

mosaico cascata B*



cm 29,5x206,5 - 11⁵/₈"x81¹/₄"
tessera cm 2,3x2,3 - 1"x1"
su rete on net sur trame auf Netz
pulpis tortora, saint laurent,
statuario oro

* Solo superficie lucida.
Lucida surface only.
Seulement surface lucida.
Nur in lucida Oberfläche.

DECORI DECORS DÉCORS DEKORE

59x118

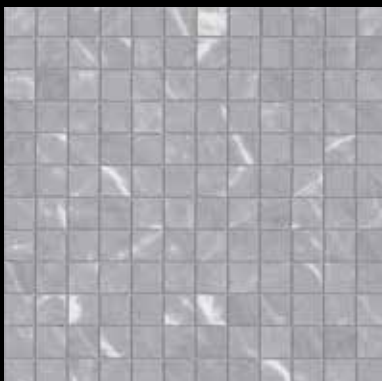
marmoker
 GRANITOKER
mosaico*

cm 29,5x29,5 - 11⁵/₈"x 11⁵/₈"
 tessera cm 2,3x2,3 - 1"x1"
su rete on net sur trame auf Netz
 Superficie naturale e lucida.
 Matt and lucida surface.
 Surface naturelle et lucida.
 Matte und lucida Oberfläche.

mosaico 5x10*

cm 29,5x29,5 - 11⁵/₈"x 11⁵/₈"
 tessera cm 5x10 - 2"x4"
su rete on net sur trame auf Netz
 Superficie naturale e lucida.
 Matt and lucida surface.
 Surface naturelle et lucida.
 Matte und lucida Oberfläche.

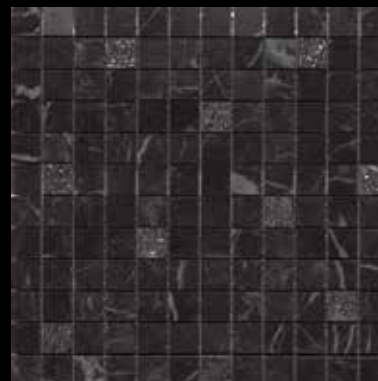
mosaico decoro**

cm 29,5x29,5 - 11⁵/₈"x 11⁵/₈"
 tessera cm 2,3x2,3 - 1"x1"
su rete on net sur trame auf Netz
 Solo superficie lucida.
 Lucida surface only.
 Seulement surface lucida.
 Nur in lucida Oberfläche.

* Disponibile in tutti i colori della serie.
 Available in all the colours
 of the series.
 Disponible dans tous les couleurs
 de la série.
 Verfügbar in allen farben.

** Disponibile nei colori:
 Available in the colours:
 Disponible dans les couleurs:
 Verfügbar in den folgenden Farben:
**Bardiglio imperiale, Nero creta,
 Pulpis tortora, Saint laurent,
 Statuario grigio**

*** Disponibile in tutti i colori della serie.
 Solo superficie lucida.
 Available in all the colours
 of the series. Lucida surface only.
 Disponible dans tous les couleurs
 de la série. Seulement surface lucida.
 Verfügbar in allen farben.
 Nur in lucida Oberfläche.

london***

cm 5x29,5 - 2"x11⁵/₈"

spigolo london***

cm 5x2,5 - 2"x1"

zoccolo***

cm 12,5x29,5 - 4⁷/₈"x11⁵/₈"

spigolo zoccolo***

cm 12,5x2,5 - 4⁷/₈"x1"

terminale***

cm 1x29,5 - ³/₈"x11⁵/₈"

spigolo terminale***

cm 1x1 - ³/₈"x³/₈"



zebrino, olimpo *lucida* cm 59x118 - 23¹/₄"x46¹/₂"



quadrotte C cm 29,5x29,5 - 11⁵/₈"x11⁵/₈"
bardiglio bianco, pulpis tortora lucida cm 59x59 - 23¹/₄"x23¹/₄"

DECORI DECORS DÉCORS DEKORE

59x118

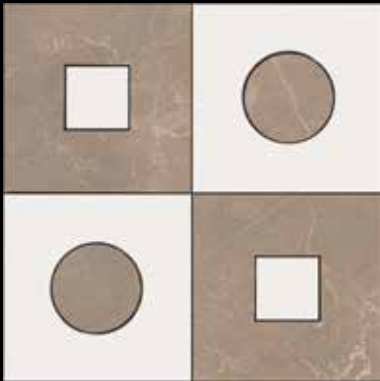
marmoker
 GRANITOKER
quadrotte*
 cm 29,5x29,5 - 11⁵/₈"x 11⁵/₈"
su rete on net sur trame auf Netz

 Solo superficie lucida.
 Lucida surface only.
 Seulement surface lucida.
 Nur in lucida Oberfläche.
cassettone travertino**
 cm 29,5x29,5 - 11⁵/₈"x 11⁵/₈"
su rete on net sur trame auf Netz

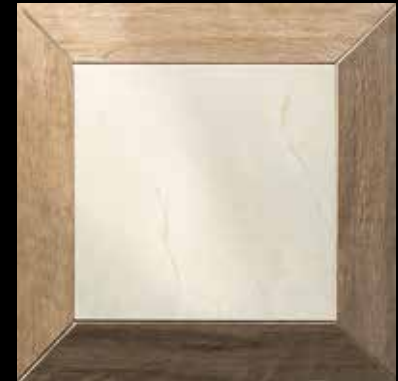
 Solo superficie lucida.
 Lucida surface only.
 Seulement surface lucida.
 Nur in lucida Oberfläche.
cassettone 3D***
 cm 29,5x29,5 - 11⁵/₈"x 11⁵/₈"
su rete on net sur trame auf Netz

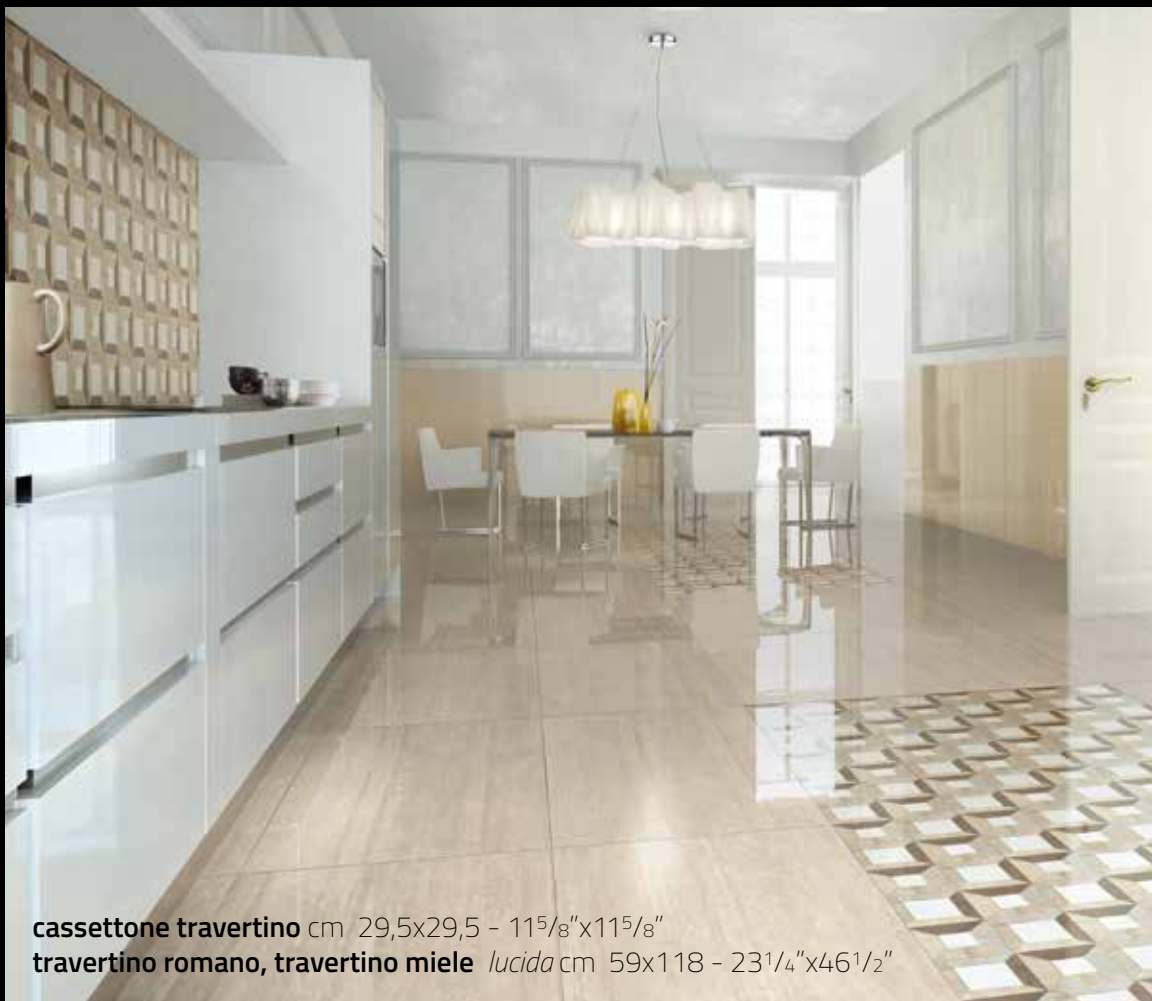
 Solo superficie lucida.
 Lucida surface only.
 Seulement surface lucida.
 Nur in lucida Oberfläche.

cassettone travertino cm 29,5x29,5 - 11⁵/₈"x11⁵/₈"
travertino romano, travertino miele *lucida* cm 59x118 - 23¹/₄"x46¹/₂"

* Disponibile nei colori: Available in the colours:
 Disponible dans les couleurs: Verfügbar in den folgenden Farben:
A Canova, Bardiglio Imperiale
B Canova, Nero creta
C Canova, Pulpis tortora

** Disponibile nei colori: Available in the colours:
 Disponible dans les couleurs: Verfügbar in den folgenden Farben:
Travertino bianco, Travertino miele,
Travertino noce, Travertino romano,
Travertino Santa Caterina

*** Disponibile nei colori: Available in the colours:
 Disponible dans les couleurs: Verfügbar in den folgenden Farben:
A Ulivo Noce + Marmoker Asiago *lucida*
B Ulivo Noce + Marmoker Statuario Oro *lucida*
C Ulivo Noce + Marmoker Travertino Noce *lucida*
D Ulivo Noce + Marmoker Crema Select *lucida*
E Ulivo Noce + Marmoker Breccia Argento *lucida*
F Tavolato Marrone Scuro + Marmoker Birimbau *lucida*
G Ulivo Grigio + Marmoker Bardiglio Imperiale *lucida*
H Ulivo Grigio + Marmoker Statuario Grigio *lucida*
I Ulivo Grigio + Marmoker Bardiglio Bianco *lucida*
L Ulivo Grigio + Marmoker Olimpo *lucida*

DECORI DECORS DÉCORS DEKORE

59x118

decoro statuario oro*

cm 29,5x59 - 11⁵/₈"x23¹/₄"

Solo superficie lucida.
Lucida surface only.
Seulement surface lucida.
Nur in lucida Oberfläche.

decoro saint laurent*

cm 29,5x59 - 11⁵/₈"x23¹/₄"

Solo superficie lucida.
Lucida surface only.
Seulement surface lucida.
Nur in lucida Oberfläche.

decoro nero creta**

cm 29,5x59 - 11⁵/₈"x23¹/₄"

Solo superficie lucida.
Lucida surface only.
Seulement surface lucida.
Nur in lucida Oberfläche.

decoro statuario grigio**

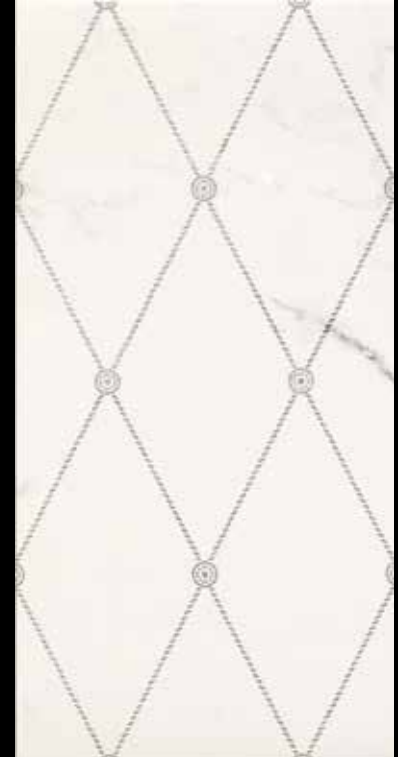
cm 29,5x59 - 11⁵/₈"x23¹/₄"

Solo superficie lucida.
Lucida surface only.
Seulement surface lucida.
Nur in lucida Oberfläche.

listello decoro*

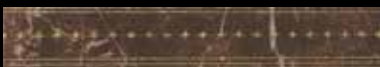
cm 5x29,5 - 2"x11⁵/₈"

Solo superficie lucida.
Lucida surface only.
Seulement surface lucida.
Nur in lucida Oberfläche.

listello decoro**

cm 5x29,5 - 2"x11⁵/₈"

Solo superficie lucida.
Lucida surface only.
Seulement surface lucida.
Nur in lucida Oberfläche.

listello marmoker oro

cm 2x29,5 - 3/4"x11⁵/₈"

Solo superficie lucida.
Lucida surface only.
Seulement surface lucida.
Nur in lucida Oberfläche.

listello marmoker argento

cm 2x29,5 - 3/4"x11⁵/₈"

Solo superficie lucida.
Lucida surface only.
Seulement surface lucida.
Nur in lucida Oberfläche.

* Disponibile nei colori:
Available in the colours:
Disponible dans les couleurs:
Verfügbar in den folgenden Farben:
**Pulpis Tortora, Saint Laurent,
Statuario Oro**

** Disponibile nei colori:
Available in the colours:
Disponible dans les couleurs:
Verfügbar in den folgenden Farben:
Nero Creta, Statuario Grigio

decoro saint laurent cm 29,5x59 - 11⁵/₈"x23¹/₄"
listello marmoker oro cm 2x29,5 - 3³/₄"x11⁵/₈"
saint laurent, statuario oro lucida cm 59x59 - 23¹/₄"x23¹/₄"
cm 9,8x59 - 3⁷/₈"x23¹/₄"

marmoker
GRANITOKER

DECORI DECORS DÉCORS DEKORE

59x118

rosone marmoker

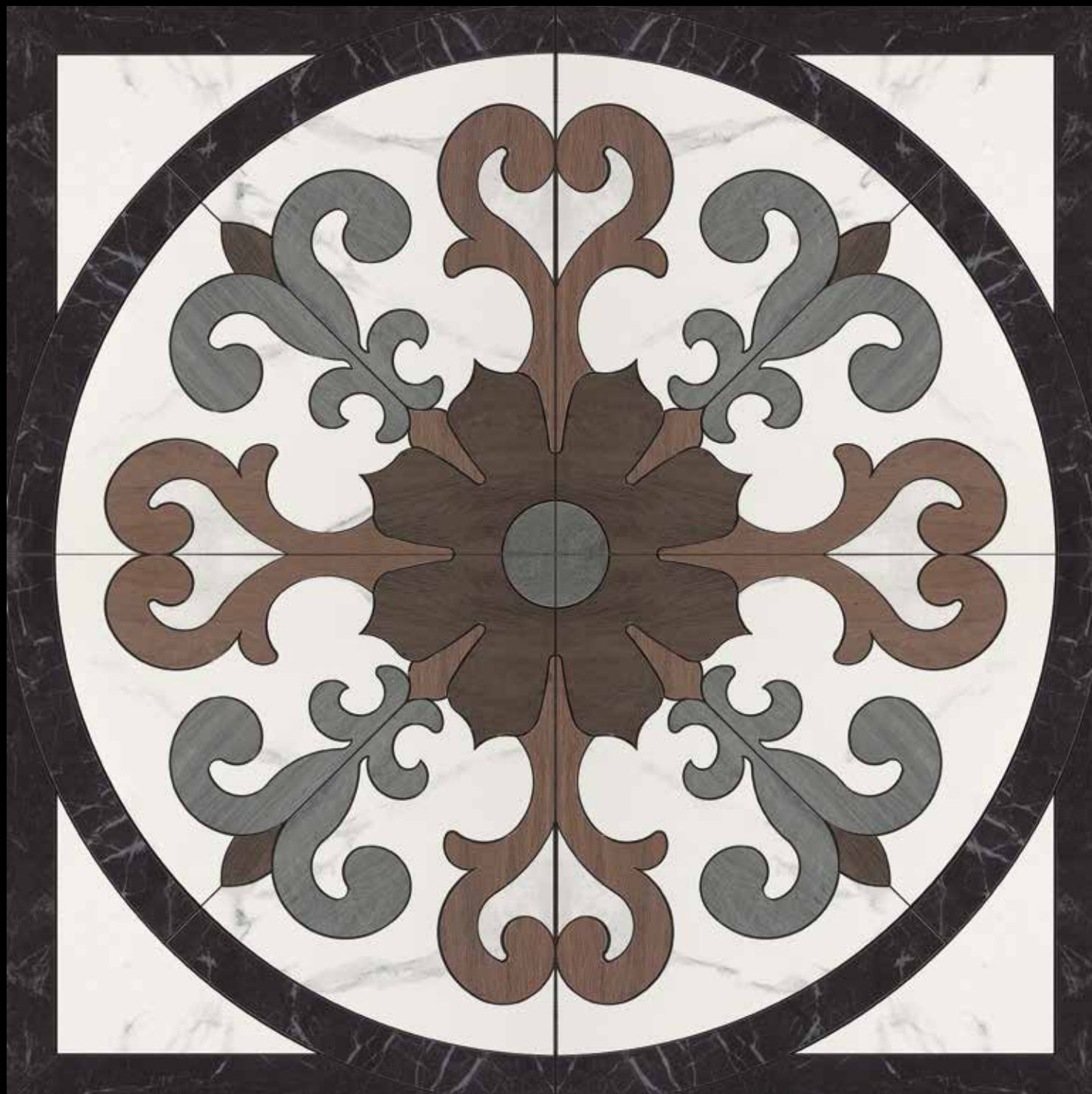
cm 118x118 - 46¹/₂"x46¹/₂"**statuario grigio, nero creta, tavolato antracite, tavolato marrone medio, tavolato marrone scuro**

Solo superficie lucida. Lucida surface only.
Seulement surface lucida. Nur in lucida Oberfläche.



breccia argento lucida cm 59x118 - 11⁵/₈"x46¹/₂"

clessidra breccia argento lucida cm 59x118 - 23¹/₄"x46¹/₂"



rosone marmoker

cm 118x118 - 46¹/₂"x46¹/₂"

* Disponibile nei colori:
Available in the colours:
Disponible dans les couleurs:
Verfügbar in den folgenden Farben:
**Bardiglio imperiale,
Breccia argento,
Saint laurent**

marmoker
GRANITOKER

clessidra*



cm 59x118 - 23¹/₄"x 46¹/₂"

Solo superficie lucida.
Lucida surface only.
Seulement surface lucida.
Nur in lucida Oberfläche.



esagoni birimbau *lucida* cm 21,5x25 - 8¹/₂"x9⁷/₈"
esagono birimbau *lucida* cm 30x51,9 - 12"x20³/₈"
birimbau *lucida* cm 59x118 - 23¹/₄"x46¹/₂"

DECORI DECORS DÉCORS DEKORE

59x118

marmoker
 GRANITOKER

esagoni*

cm 21,5x25 - 8¹/₂"x 9⁷/₈"
 su rete on net sur trame auf Netz

Solo superficie lucida.
 Lucida surface only.
 Seulement surface lueida.
 Nur in lucida Oberflache.

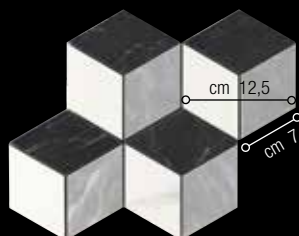
esagoni 3D**

cm 21,5x25 - 8¹/₂"x 9⁷/₈"
 su rete on net sur trame auf Netz

Solo superficie lucida.
 Lucida surface only.
 Seulement surface lueida.
 Nur in lucida Oberflache.

esagono*

cm 30x51,9 - 11³/₄"x 20³/₈"

Solo superficie lucida.
 Lucida surface only.
 Seulement surface lueida.
 Nur in lucida Oberflache.

* Disponibile nei colori:
 Available in the colours:
 Disponible dans les couleurs:
 Verfugbar in den folgenden Farben:
**Asiago, Bardiglio bianco, Birimbau,
 Bardiglio Imperiale,
 Breccia argento, Canova,
 Crema select, Giallo striato,
 Nero Creta, Olimpo, Pulpis tortora,
 Rosato, Saint Laurent,
 Statuario grigio, Statuario oro,
 Zebrino**

** Bardiglio Imperiale, Nero creta,
 Statuario grigio



DECORI DECORS DÉCORS DEKORE

90x180

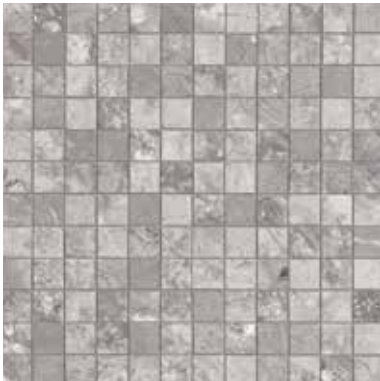
mosaico*

cm 30x30 - 11³/₄"x 11³/₄"
 tessera cm 2,3x2,3 - 1"x1"
su rete on net sur trame auf Netz

Solo superficie lucida.
 Lucida surface only.
 Seulement surface lucida.
 Nur in lucida Oberfläche.

mosaico 5x10*

cm 30x30 - 11³/₄"x 11³/₄"
 tessera cm 5x10 - 2"x4"
su rete on net sur trame auf Netz

Solo superficie lucida.
 Lucida surface only.
 Seulement surface lucida.
 Nur in lucida Oberfläche.

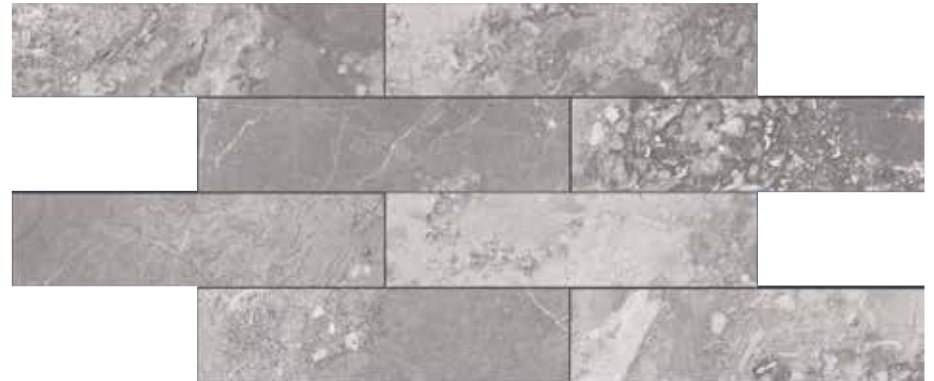
composizione D*

cm 28,5x57,6 - 11¹/₄"x22⁵/₈"
 ogni mattoncino: cm 7x28,7 - 2³/₄"x11¹/₄"
su rete on net sur trame auf Netz

Solo superficie lucida.
 Lucida surface only.
 Seulement surface lucida.
 Nur in lucida Oberfläche.

london*

cm 5x30 - 2"x11³/₄"

spigolo london*

cm 5x2,5 - 2"x1"

* Disponibile in tutti i colori della serie.
 Solo superficie lucida.
 Available in all the colours
 of the series. Lucida surface only.
 Disponible dans tous les couleurs
 de la série. Seulement surface lucida.
 Verfügbar in allen Farben.
 Nur in lucida Oberfläche.

zoccolo*

cm 12,5x30 - 4⁷/₈"x11³/₄"

spigolo zoccolo*

cm 12,5x2,5 - 4⁷/₈"x1"

terminale*

cm 1x30 - 3³/₈"x11³/₄"

spigolo terminale*

cm 1x1 - 3³/₈"x3³/₈"

marmoker
GRANITOKER

statuario bianco *lucida* cm 90x90 - 35³/₈"x35³/₈", **grafite marrone** *matt* cm 90x90 - 35³/₈"x35³/₈"

marTE
GRANITOGRES



thassos cm 60x120 - 23⁵/₈"x47¹/₄"

COLORI COLOURS COULEURS FARBEN

nero acapulco



grigio maglia

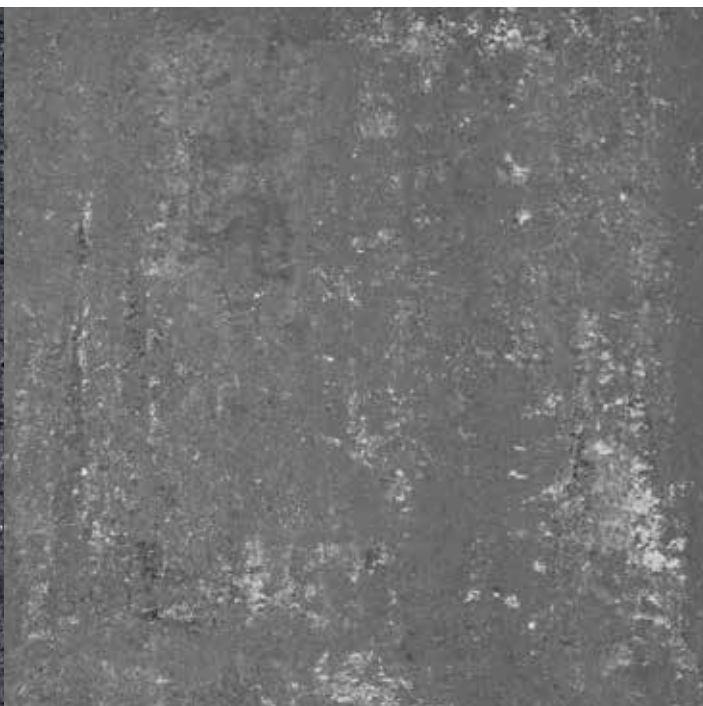

grigio marostica



emperador



ramora brown



bronzetto

marTE
GRANITOGRES

raggio di luna



grigio egeo



thassos



crema marfil



palissandro



botticino

COLORI COLOURS COULEURS FARBEN

azul bahia



azul macauba

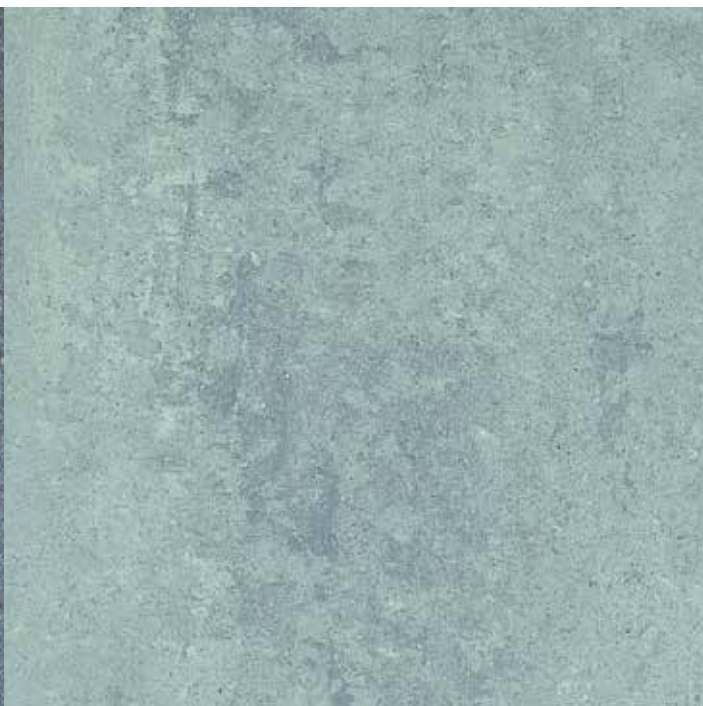

verde guatemala

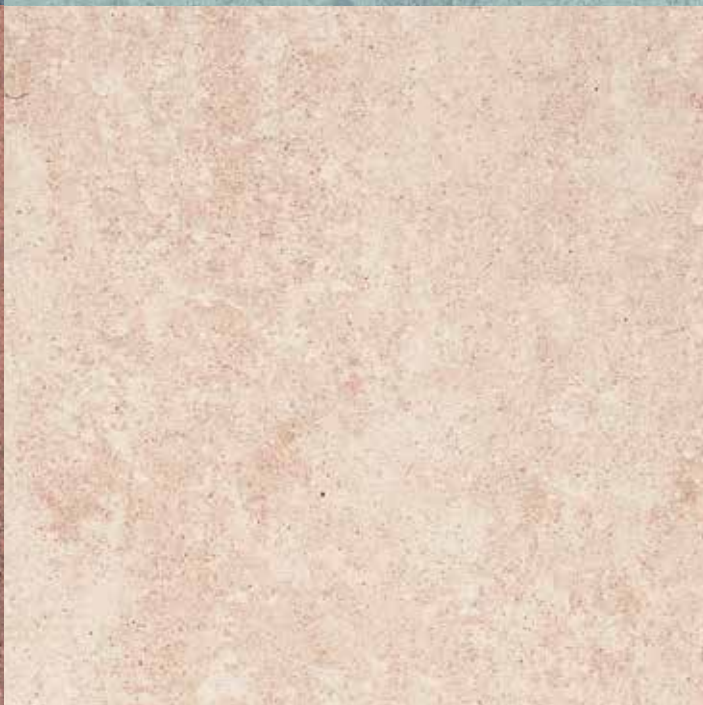

madras pink









rosa portogallo

marte
GRANITOGRES



grigio maggia cm 60x60 - 23⁵/₈"x23⁵/₈"

FORMATI SIZES FORMATS FORMATE

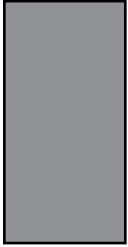
Formati Sizes Formats Formate										
	cm 15x15 5 ⁷ / ₈ "x5 ⁷ / ₈ "	cm 30x30 11 ³ / ₄ "x11 ³ / ₄ "	cm 40x40 15 ³ / ₄ "x15 ³ / ₄ "	cm 10x60 4"x23 ⁵ / ₈ "	cm 15x60 5 ⁷ / ₈ "x23 ⁵ / ₈ "	cm 20x60 7 ⁷ / ₈ "x23 ⁵ / ₈ "	cm 30x60 11 ³ / ₄ "x23 ⁵ / ₈ "	cm 60x60 23 ⁵ / ₈ "x23 ⁵ / ₈ "	cm 20x120 7 ⁷ / ₈ "x47 ¹ / ₄ "	cm 60x120 23 ⁵ / ₈ "x47 ¹ / ₄ "
Superfici Surfaces Surfaces Oberflächen	● ● ● ●	● ● ● ●	● ● ● ●	● ● ● ●	● ● ● ●	● ● ● ●	● ● ● ●	● ● ● ●	● ● ●	● ● ●
Spessori* Thicknesses* Épaisseurs* Stärken*	mm 9,4	mm 9,4	mm 9,4	mm 9,4	mm 9,4	mm 10,5	mm 9,4	mm 10,5	mm 10,5	mm 10,5

- Naturale Matt Naturelle Matt **R9 A** (A richiesta On request Sur demande Auf Anfrage **R10**)
- Levigata Polished Polie Poliert
- Satinata Satin Finished Satinée Satiniert
- Bocciardata **R11 A+B**

Caratteristiche tecniche e imballi a pagina
 Technical features and packing on page
 Caractéristiques techniques et emballages à la page
 Technische Eigenschaften und Verpackungen auf Seite
444

* Spessore su superficie naturale e satinata.
 Thickness on matt and satinized surface.
 Épaisseur sur surface mat et satinée.
 Stärke der Fliesen mit Matt - satinierten Oberfläche.

Su richiesta possono essere forniti i formati ottenibili per taglio e/o gli spessori 12,3 mm e 14,2 mm.
 Per poter uniformare gli spessori, specificare al momento dell'ordine una eventuale posa in opera combinata di formati diversi.
 On request we can supply the sizes obtained by cutting and/or the thicknesses both 12,3 mm and 14,2 mm.
 In order to standardize the thickness, please specify when ordering an eventual installation combining different sizes.
 Sur demande peuvent être fournis : les formats obtenus par découpe et/ou les épaisseurs 12,3 mm et 14,2 mm.
 Afin d'uniformiser les épaisseurs, veuillez préciser au moment de la commande si vous effectuez une pose combinée de formats différentes.
 Auf Anfrage können sowohl die Formate geschnitten als auch die Stärke 12,3mm und 14,2mm geliefert werden um die Fliesenstärken aneinander anpassen zu können, bitte bei der Bestellung angeben, dass Fliesen mit verschiedenen Formate zusammen verlegt werden sollen.

PEZZI SPECIALI TRIMS ACCESSOIRES FORMSTÜCKE

Battiscopa Bullnose
Plinthe à bord arrondi Stehsockel

cm 9x30 - 3½"x11¾"
 cm 9x40 - 3½"x15¾"
 cm 9x60 - 3½"x23⅝"

**Gradino Step tread**
Nez de marche Stufenplatte

cm 30x30 - 11¾"x11¾"
 cm 30x60 - 11¾"x24"

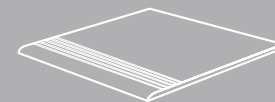
**Listello Listel**
Listel Zeilerleiste

cm 9x30 - 3½"x11¾"
 cm 9x40 - 3½"x15¾"
 cm 9x60 - 3½"x23⅝"



* **Zoccolo a raccordo a becco civetta**
Cove base with rounded edge
Plinthe à gorge bord arrondi
Hohlkehlsocbel mit abgerundeter Kante
 cm 15x30 - 5⅞"x11¾"



Gradone toro con bordo antiscivolo
Gradone toro with non-slip edge
Gradone toro avec nez antidérapant
Gradone toro mit rutschsicherer Kante
 cm 60x33 - 23⅝"x13"

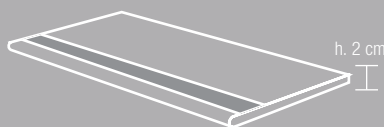

Angolare toro con bordo antiscivolo
Angolare toro with non-slip edge
Angolare toro avec nez antidérapant
Angolare toro mit rutschsicherer Kante
 cm 60x33 - 23⅝"x13"

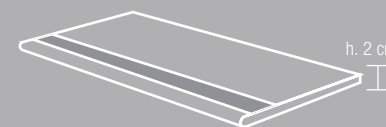

Gradone toro
 cm 60x33 - 23⅝"x13"
 cm 120x33 - 47¼"x13"



Angolare toro
 cm 60x33 - 23⅝"x13"
 cm 120x33 - 47¼"x13"



Scalino
 cm 40x33 - 15¾"x13"

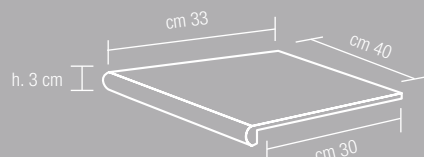

Scalino angolare
 cm 40x33 - 15¾"x13"

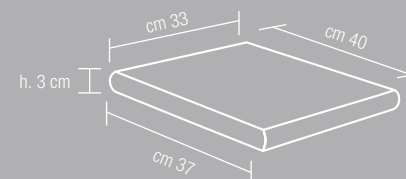

Gradone (assemblato)
 cm 30x33 - 11¾"x13"
 cm 60x33 - 23⅝"x13"

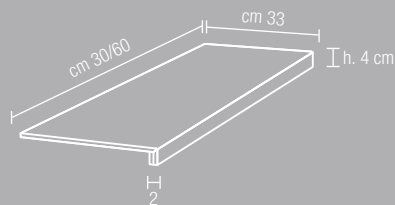

Angolare (assemblato)
 cm 30x33 - 11¾"x13"
 cm 60x33 - 23⅝"x13"

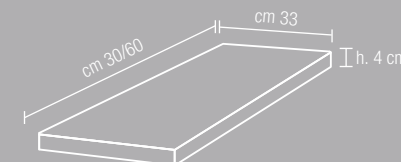

** **Battiscala DX**
 cm 39x27 - 15⅝"x10⅝"

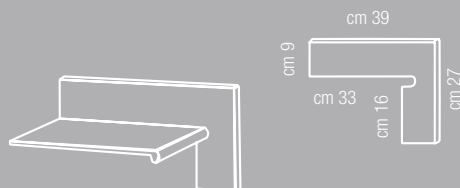

** **Battiscala SX**
 cm 39x27 - 15⅝"x10⅝"

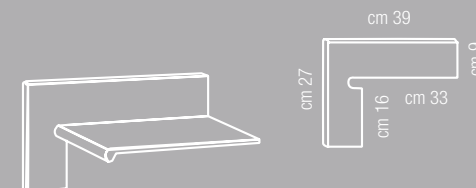

* Non rettificato Not rectified Non rectifié Nicht rektifiziert

Produzione corrente solo nei colori: Currently produced only in the following colours: Productions courantes seulement dans les couleurs: Aktuelle Produktion nur in den Farben:

botticino, bronzetto, grigio egeo, nero acapulco, palissandro, raggio di luna, thassos

Altri colori a richiesta. Other colours available on request. Autres couleurs sur demande. Weitere Farben auf Wunsch.

** Solo su ordinazione. Attention! Specificare nell'ordine se il battiscala deve essere abbinato a scalino (h. 3 cm) o a gradone toro (h. 2,2 cm).

Only on request. Important! The order must specify whether the battiscala must match a scalino (3 cm h.) or a gradone toro (2,2 cm h.).

Seulement sur commande. Attention! Spécifier dans la commande si le battiscala doit être assorti au scalino (h. 3cm) ou au gradone toro (h. 2,2 cm).

Nur auf Bestellung. Achtung! Beim Auftrag ist es zu vermerken, ob die Stufensockel (battiscala) zusammen mit dem scalino (3 cm hoch) bzw. Dem gradone toro (2,2 cm hoch) zu kombinieren sind.

SUPERFICI SURFACES SURFACES OBERFLÄCHEN

levigata polished polie poliert

satinata satin finished satinée satiniert

naturale matt naturelle matt R9 A

bocciardata bouchardée
gehämmert R11 A+B

DECORI DECORS DÉCORS DEKORE

marTE
GRANITOGRES

mosaico fresato*

cm 30x30 - 11³/₄"x11³/₄"
tessera cm 3x3 - 1¹/₈"x1¹/₈"

Superficie naturale e levigata.
Matt and polished surface.
Surface naturelle et polie.
Matte und polierte Oberfläche.

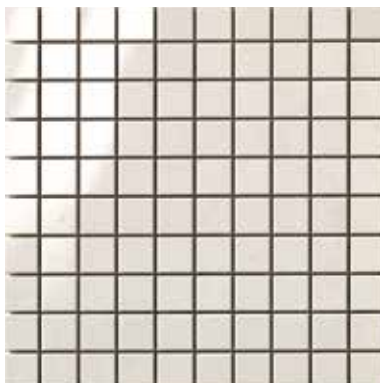
mosaico*

cm 30x30 - 11³/₄"x11³/₄"
tessera cm 3x3 - 1¹/₈"x1¹/₈"
su rete on net sur trame auf Netz

Solo superficie levigata.
Polished surface only.
Seulement surface polie.
Nur in polierter Oberfläche.

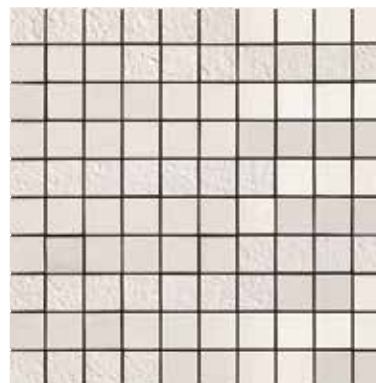
mosaico texture**

cm 30x30 - 11³/₄"x11³/₄"
tessera cm 3x3 - 1¹/₈"x1¹/₈"
su rete on net sur trame auf Netz

Naturale, levigato, bocciardato.
Matt, polished, bocciardato.
Naturel, poli, bouchardé.
Matt, poliert, gehämmert.

* Disponibile in tutti i colori della serie.
Available in all the colours
of the series.
Disponibile dans tous les couleurs
de la série.
Verfügbar in allen Farben.

listelli*

cm 30x30 - 11³/₄"x11³/₄"
listello cm 3x30 - 1¹/₈"x11³/₄"
su rete on net sur trame auf Netz

Solo superficie levigata.
Polished surface only.
Seulement surface polie.
Nur in polierter Oberfläche.

listelli texture*

cm 30x30 - 11³/₄"x11³/₄"
listello cm 3x30 - 1¹/₈"x11³/₄"
su rete on net sur trame auf Netz

Naturale, levigato, bocciardato.
Matt, polished, bocciardato.
Naturel, poli, bouchardé.
Matt, poliert, gehämmert.



listelli texture thassos cm 30x30 - 11³/₄"x11³/₄"
thassos cm 60x120 - 23⁵/₈"x47¹/₄"

DECORI DECORS DÉCORS DEKORE

mosaico mix A*



cm 30x30 - 11³/₄"x11³/₄"
 tessera cm 2,2x2,2 - 7/8"x7/8"
su rete on net sur trame auf Netz
**bianco assoluto, azul bahia,
 azul macauba**

mosaico mix B*



cm 30x30 - 11³/₄"x11³/₄"
 tessera cm 2,2x2,2 - 7/8"x7/8"
su rete on net sur trame auf Netz
**bianco assoluto, azul bahia,
 azul macauba, acciaio**

mosaico mix C*



cm 30x30 - 11³/₄"x11³/₄"
 tessera cm 2,2x2,2 - 7/8"x7/8"
su rete on net sur trame auf Netz
**grigio egeo, grigio maggia,
 raggio di luna**

mosaico mix D*



cm 30x30 - 11³/₄"x11³/₄"
 tessera cm 2,2x2,2 - 7/8"x7/8"
su rete on net sur trame auf Netz
**grigio egeo, grigio maggia,
 raggio di luna, acciaio**

mosaico mix E*



cm 30x30 - 11³/₄"x11³/₄"
 tessera cm 2,2x2,2 - 7/8"x7/8"
su rete on net sur trame auf Netz
**rosa portogallo,
 rosso soraya, madras pink**

mosaico mix F*



cm 30x30 - 11³/₄"x11³/₄"
 tessera cm 2,2x2,2 - 7/8"x7/8"
su rete on net sur trame auf Netz
**botticino, bronzetto,
 palissandro, verde guatemala**



mosaico texture thassos cm 30x30 - 11³/₄"x11³/₄"

* Produzione standard su superficie levigata.
 Standard production with polished surface.
 Production standard pour la surface polie.
 Standardausführung in polierter Oberfläche.

decoro A*



cm 30x30 - 11³/₄"x11³/₄"
 tessera cm 3x7,5 - 1¹/₈"x3"

decoro B*

cm 30x30 - 11³/₄"x11³/₄"
 tessera cm 7,5x15 - 3"x5⁷/₈"

matita*

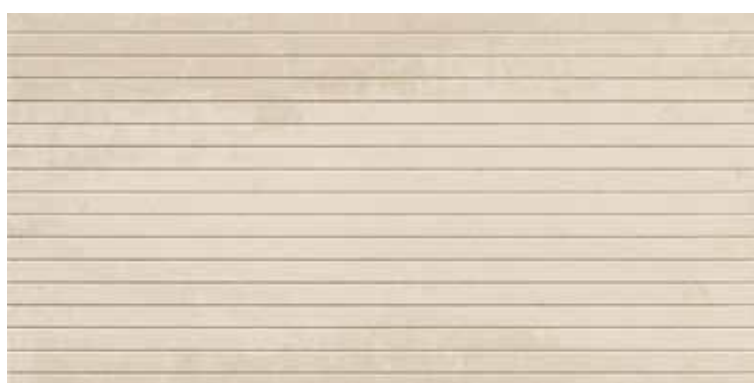
cm 1x30 - 3³/₈"x11³/₄"

decoro C*

cm 30x60 - 11³/₄"x23⁵/₈"
 listello cm 1,5x60 - 5⁵/₈"x23⁵/₈"

decoro D*

cm 30x60 - 11³/₄"x23⁵/₈"
 listello cm 7,5x60 - 3"x23⁵/₈"

listello strass thassos**

cm 4x60 - 1⁵/₈"x23⁵/₈"

listello strass nero acapulco**

cm 4x60 - 1⁵/₈"x23⁵/₈"

listello strass thassos

cm 4x60 - 1⁵/₈"x23⁵/₈"

thassos

cm 15x60 - 5⁷/₈"x23⁵/₈"

30x60 - 11³/₄"x23⁵/₈"

* Disponibile in tutti i colori della serie, solo nella versione naturale.
 Available in all the colours of the series, only in matt version.
 Disponible dans toutes les couleurs de la série, seulement dans la version naturelle.
 Verfügbar in allen Farben, nur in matt.

** Produzione standard su superficie levigata.
 Standard production with polished surface.
 Production standard pour la surface polie.
 Standardausführung in polierter Oberfläche.

Complementi in acciaio e alluminio a pagina
 Technical features on page
 Caractéristiques techniques à la page
 Technische eigenschaften auf Seite
457

marmogres calacatta grigio

marmogres
GRANITOGRES



calacatta grigio *levigato polished* cm 60x60 - 23⁵/₈"x23⁵/₈"

COLORI COLOURS COULEURS FARBEN

nero marquinia



portoro



verde india



cremo supremo



pennsylvania



paonazzetto

marmogres

GRANITOGRES

rosso laguna



giallo siena

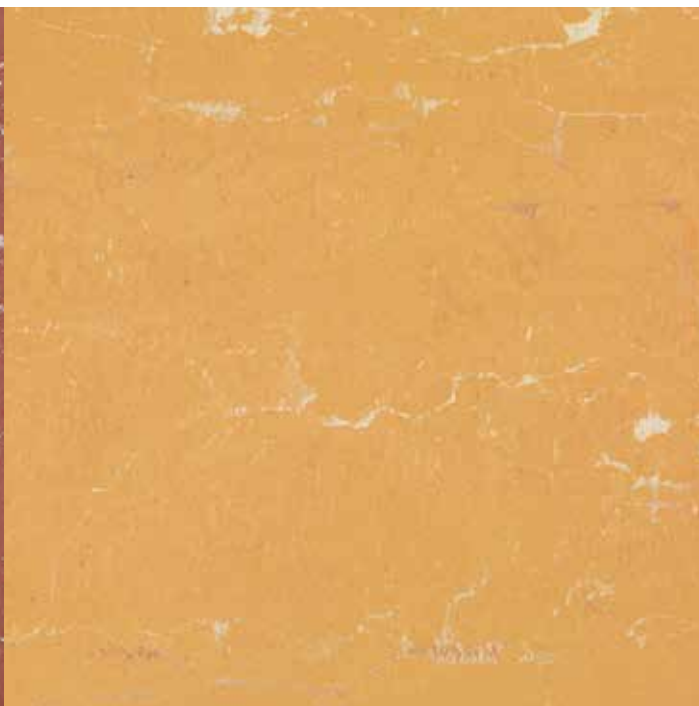

pennsylvania *levigato polished*
cm 60x60 - 23⁵/₈"x23⁵/₈"



calacatta beige





calacatta grigio



paonazzetto, giallo siena *levigato polished*
cm 60x60 - 23⁵/₈"x23⁵/₈"

FORMATI SIZES FORMATS FORMATE

Formati Sizes Formats Formate	 cm 30x30 11 ³ / ₄ "x11 ³ / ₄ "	 cm 30x60 11 ³ / ₄ "x23 ⁵ / ₈ "	 cm 60x60 23 ⁵ / ₈ "x23 ⁵ / ₈ "
Superfici Surfaces Surfaces Oberflächen	● ●	● ●	● ●
Spessori Thicknesses Epaisseurs Stärken	mm 10	mm 10	mm 10
<ul style="list-style-type: none"> ● Levigata Polished Polie Poliert ● Honed 		Caratteristiche tecniche e imballi a pagina Technical features and packing on page Caractéristiques techniques et emballages à la page Technische Eigenschaften und Verpackungen auf Seite 444	

PEZZI SPECIALI TRIMS ACCESSOIRES FORMSTÜCKE

Battiscopa Bullnose
Plinthe à bord arrondi Stehsockel
 cm 9x30 - 3¹/₂"x11³/₄"
 cm 9x60 - 3¹/₂"x23⁵/₈"



Gradino Step tread
Nez de marche Stufenplatte
 cm 30x30 - 11³/₄"x11³/₄"
 cm 30x60 - 11³/₄"x23⁵/₈"

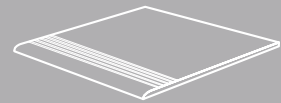

Tozzetto Insert
Cabochon Einleger
 cm 9x9 - 3¹/₂"x3¹/₂"



Listello Listel
Listel Zeierleiste
 cm 9x30 - 3¹/₂"x11³/₄"
 cm 9x60 - 3¹/₂"x23⁵/₈"



Scalino
 cm 60x33 - 23⁵/₈"x13"

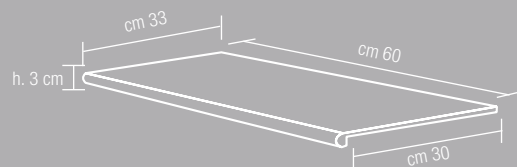

Scalino angolare
 cm 60x33 - 23⁵/₈"x13"

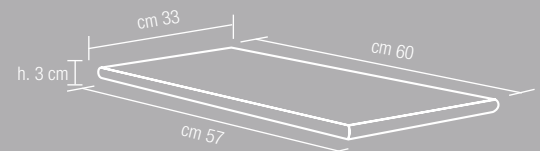

SUPERFICI SURFACES SURFACES OBERFLÄCHEN

marmogres
GRANITOGRES

levigata polished polie poliert

honed

DECORI DECORS DÉCORS DEKORE

rosone classico marmogres*

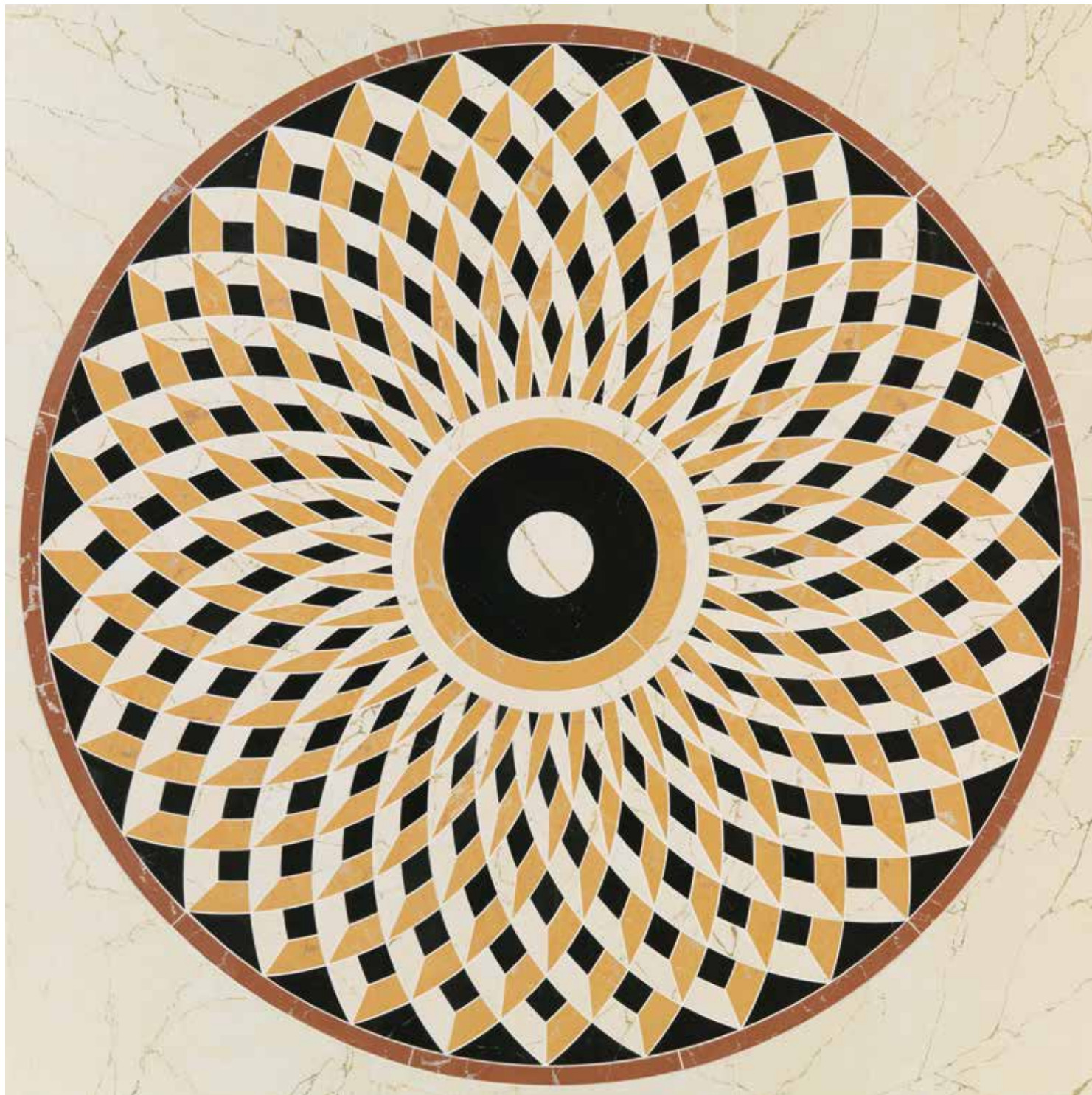
cm 180x180 - 70⁷/₈"x70⁷/₈"**giallo siena, paonazetto, nero marquinia, rosso laguna**Produzione standard su superficie levigata. Standard production with polished surface.
Production standard pour la surface polie. Standardausführung in polierter Oberfläche.

marmogres

GRANITOGRES

mosaico scacchiera A*

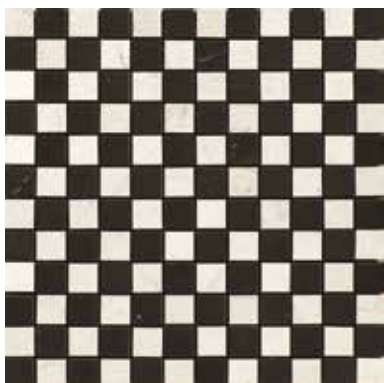

cm 30x30 - 11³/₄"x11³/₄"
 tessera cm 2,2x2,2 - 7/8"x7/8"
su rete on net sur trame auf Netz
 nero marquinia, pennsylvania

mosaico scacchiera B*

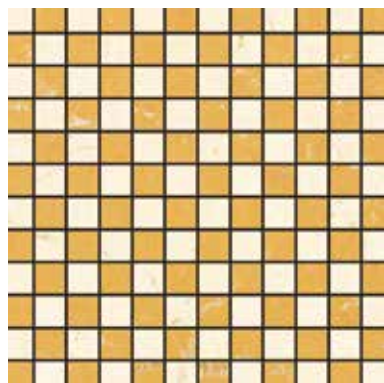

cm 30x30 - 11³/₄"x11³/₄"
 tessera cm 2,2x2,2 - 7/8"x7/8"
su rete on net sur trame auf Netz
 giallo siena, paonazzetto

mosaico**



cm 30x30 - 11³/₄"x11³/₄"
 tessera cm 2,2x2,2 - 7/8"x7/8"
su rete on net sur trame auf Netz

* Produzione standard su superficie levigata.
 Standard production with polished surface.
 Production standard pour la surface polie.
 Standardausführung in polierter Oberfläche.

** Disponibile nei colori:
 Available in the colours:
 Disponible dans les couleurs:
 Verfügbar in den folgenden Farben:
Portoro, Rosso Laguna, Giallo Siena

rosone floreale marmogres*



cm 240x120 - 96"x48"
 paonazzetto, pennsylvania, portoro, rosso laguna, giallo siena, verde india

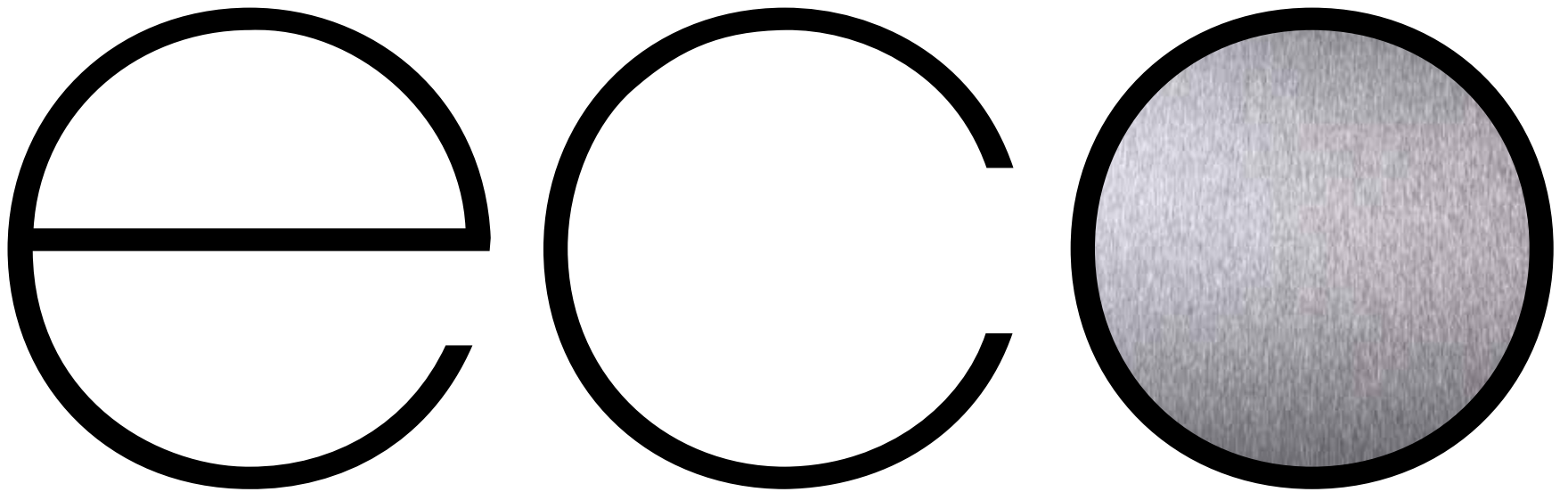

eco**metal** éco**métal** öko**metall**

metallo

ecometallo

232 **steeltech**

238 **metallica**

METALLO

Elemento chimico dotato di buona conducibilità termica ed elettrica, elevata tenacità, duttilità e malleabilità che lo qualificano come uno dei materiali maggiormente utilizzati a livello industriale. Caratterizzato dal potere riflettente e dall'opacità alla luce è in grado di formare con l'ossigeno ossidi a carattere più o meno spiccatamente basico.

METAL

A very strong, ductile and malleable chemical element with good thermal and electric conductivity that make it one of the most widely used materials for industrial applications. Standing out for its reflective power and opaqueness to light, it can bind to oxygen to form more or less alkaline oxides.

steeltech
GRANITOKER



corten lappata, beige cm 90x90 - 35³/₈"x35³/₈"

COLORI COLOURS COULEURS FARBEN

antracite



corten



grigio

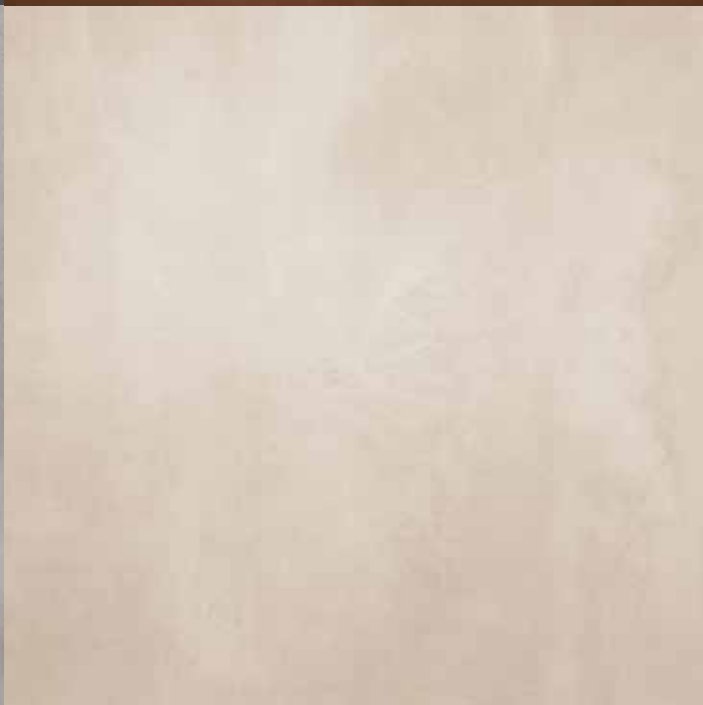

beige

SUPERFICI SURFACES SURFACES OBERFLÄCHEN

steeltech
GRANITOKER

lappata

naturale matt naturelle matt R9

FORMATI SIZES FORMATS FORMATE

Formati Sizes Formats Formate	cm 60x60 23 ⁵ / ₈ "x23 ⁵ / ₈ "	cm 45x90 17 ³ / ₄ "x35 ³ / ₈ "	cm 90x90 35 ³ / ₈ "x35 ³ / ₈ "
Superfici Surfaces Surfaces Oberflächen	● ●	● ●	● ●
Spessori Thicknesses Epaisseurs Stärken	mm 10	mm 10,5	mm 10,5
<ul style="list-style-type: none"> ● Naturale Matt Naturelle Matt R9 ● Lappata 		 <p>Media Medium Moyenne Mittel</p>	<p>Caratteristiche tecniche e imballi a pagina Technical features and packing on page Caractéristiques techniques et emballages à la page Technische Eigenschaften und Verpackungen auf Seite 450</p>

PEZZI SPECIALI TRIMS ACCESSOIRES FORMSTÜCKE

Battiscopa Bullnose
Plinthe à bord arrondi Stehsockel
cm 9x60 - 3¹/₂"x23⁵/₈"
cm 9x90 - 3¹/₂"x35³/₈"



Gradino Step tread
Nez de marche Stufenplatte
cm 30x60 - 11³/₄"x23⁵/₈"
cm 30x90 - 11³/₄"x35³/₈"



Gradone (assemblato)
cm 90x33 - 35³/₈"x13"

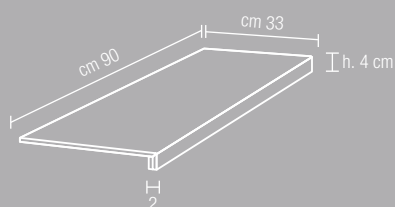

Angolare (assemblato)
cm 90x33 - 35³/₈"x13"

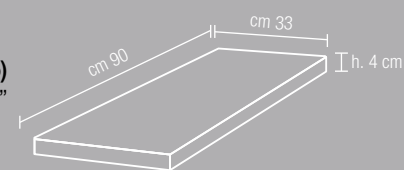

DECORI DECORS DÉCORS DEKORE

steeltech
GRANITOKER

decoro steeltech*

cm 90x90 - 35³/₈"x35³/₈"

Superficie naturale e lappata. Matt and lappata surface.
Surface naturelle et lappata. Matt und lappata Oberfläche.

mosaico 6x6*



cm 30x30 - 11³/₄"x11³/₄"
tessera cm 6x6 - 2³/₈"x2³/₈"
su rete on net sur trame auf Netz

Superficie naturale e lappata.
Matt and lappata surface.
Surface naturelle et lappata.
Matt und lappata Oberfläche.

* Disponibile in tutti i colori della serie.
Available in all the colours of the series.
Disponible dans tous les couleurs de la série.
Verfügbar in allen Farben.

metallica
GRANITOKER

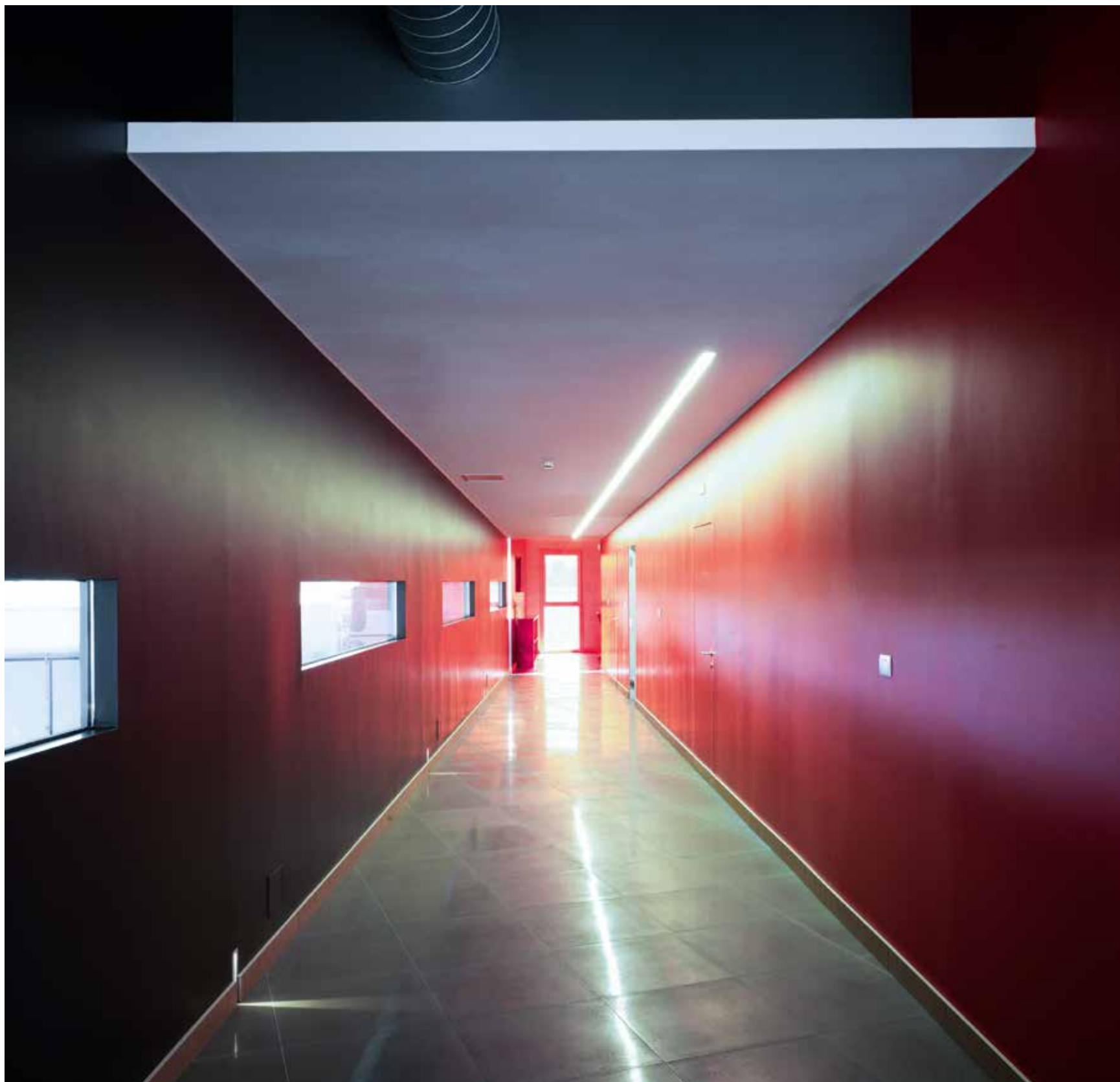

inox lappato cm 60x60 - 23⁵/₈"x23⁵/₈"

COLORI COLOURS COULEURS FARBEN

ferro lappato



inox lappato

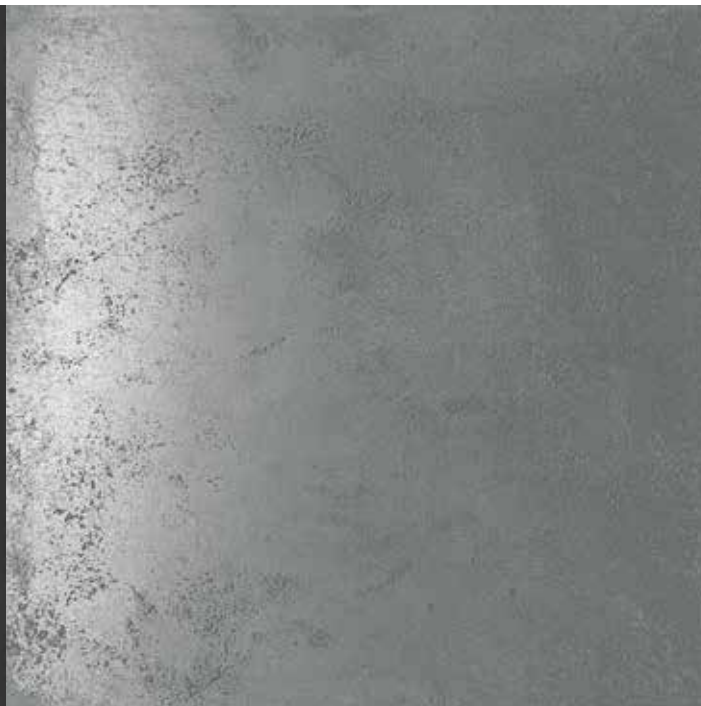

rame lappato



zinco-titanio lappato



metallica
GRANITOKER

ferro lappato cm 60x60 - 23⁵/₈"x23⁵/₈"

FORMATI SIZES FORMATS FORMATE

Formati Sizes Formats Formate	 cm 30x60 11 ³ / ₄ "x23 ⁵ / ₈ "	 cm 60x60 23 ⁵ / ₈ "x23 ⁵ / ₈ "
Superfici Surfaces Surfaces Oberflächen	●* ●	●* ●
Spessori Thicknesses Epaisseurs Stärken	mm 10,5	mm 10,5
<ul style="list-style-type: none"> ● Naturale Matt Naturelle Matt * Escluso Inox, Zinco-Titanio Inox, Zinco-Titanio excluded Exclue Inox, Zinco-Titanio Ausser Inox, Zinco-Titanio) R9 ● Lappata 	Caratteristiche tecniche e imballi a pagina Technical features and packing on page Caractéristiques techniques et emballages à la page Technische Eigenschaften und Verpackungen auf Seite 450	

PEZZI SPECIALI TRIMS ACCESSOIRES FORMSTÜCKE

Battiscopa Bullnose
Plinthe à bord arrondi Stehsockel
 cm 9x60 - 3¹/₂"x23⁵/₈"



Gradino Step tread
Nez de marche Stufenplatte
 cm 30x60 - 11³/₄"x23⁵/₈"

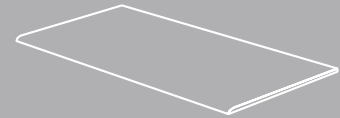

Gradone (assemblato)
 cm 60x33 - 23⁵/₈"x13"

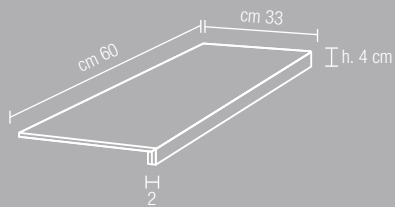

Angolare (assemblato)
 cm 60x33 - 23⁵/₈"x13"

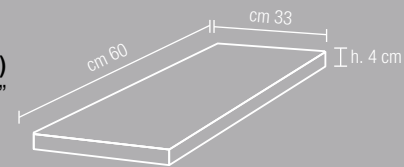

Gradino Metal
 cm 30x60 - 11³/₄"x23⁵/₈"

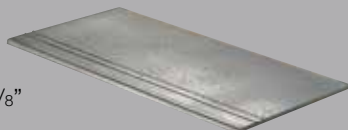

SUPERFICI SURFACES SURFACES OBERFLÄCHEN

metallica
GRANITOKER

lappata

naturale matt naturelle matt R9

DECORI DECORS DÉCORS DEKORE

decoro A*

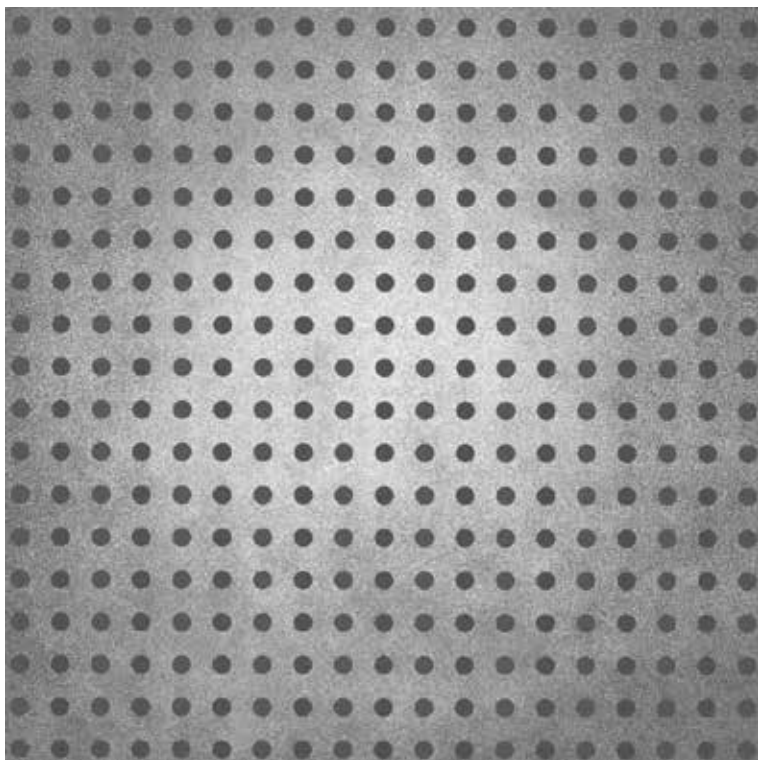
cm 60x60 - 23⁵/₈"x23⁵/₈"

decoro B*

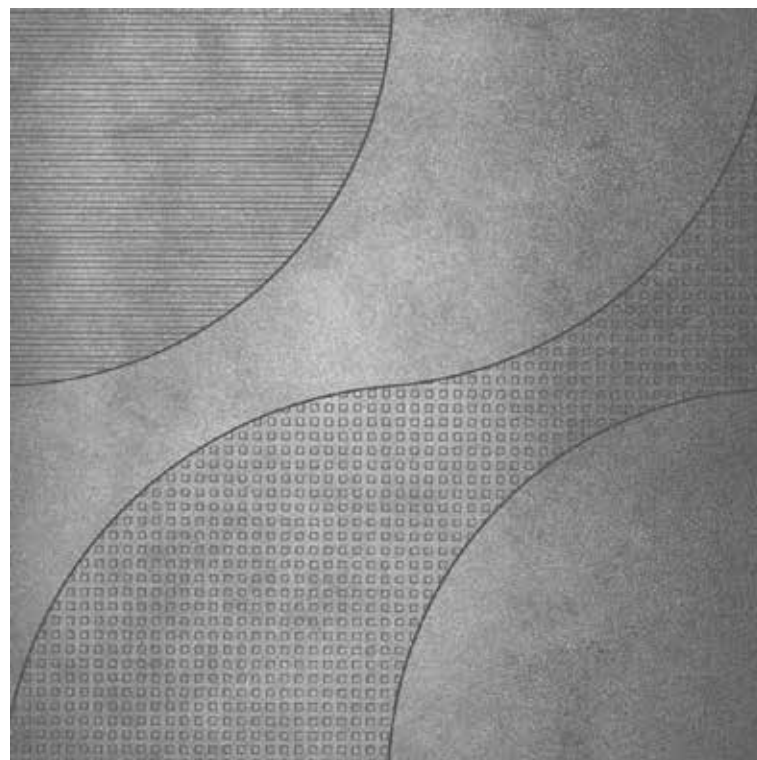
cm 60x60 - 23⁵/₈"x23⁵/₈"

* Disponibile in tutti i colori della serie, superficie naturale e lappata. Available in all the colours of the series, matt and "lappata" surface.
 Disponible dans tous les couleurs de la série, surface naturelle et "lappata". Verfügbar in allen Farben, matt und "lappata" Oberfläche.

mosaico ferro lappato



cm 30x30 - 11³/₄"x11³/₄"
 tessera cm 2,2x2,2 - 7/8"x7/8"
 su rete on net sur trame auf Netz

mosaico inox lappato



cm 30x30 - 11³/₄"x11³/₄"
 tessera cm 2,2x2,2 - 7/8"x7/8"
 su rete on net sur trame auf Netz

mosaico rame/
nichel lappato

cm 30x30 - 11³/₄"x11³/₄"
 tessera cm 2,2x2,2 - 7/8"x7/8"
 su rete on net sur trame auf Netz

metallica

GRANITOKER

ferro, zinco-titanio cm 60x60 - $23\frac{3}{8}'' \times 23\frac{5}{8}''$, 30x60 - $11\frac{3}{4}'' \times 23\frac{5}{8}''$

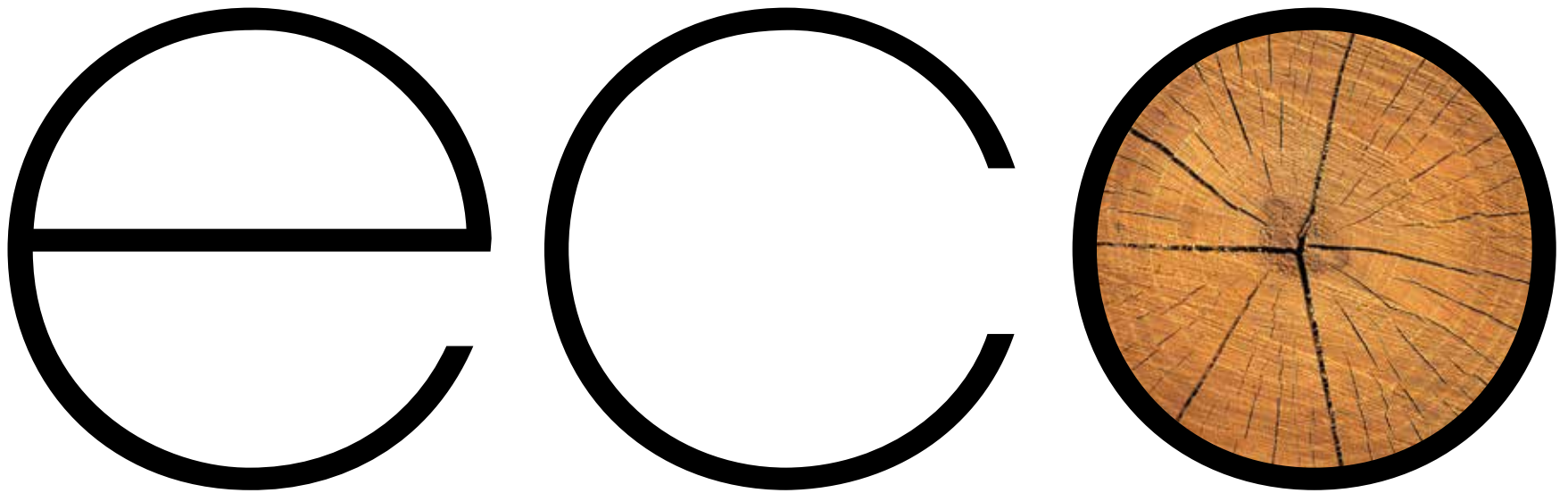

eco**wood** éco**bois** öko**holz**

legno

ecolegno

250 **antique wood**

256 **tavolato**

262 **ulivo**

268 **newood**

276 **metalwood**

282 **parchi**

LEGNO

Insieme dei tessuti vegetali [xiloma] che formano la parte solida del fusto, dei rami e delle radici degli alberi. La parte più vecchia e più interna del tronco è detta durame, la parte più giovane e periferica albume. Il legno sin dall'antichità ha trovato notevoli applicazioni nella produzione della carta, nell'edilizia, nell'industria manifatturiera.

WOOD

The group of vegetable tissues [xylem] that form the solid part of the tree trunk, branches and roots. The oldest and innermost part of the trunk is also known as hardwood, while the youngest and outermost part of the trunk is known as sapwood. Since antiquity, wood has been widely used to make paper, in the building and manufacturing industries, in design.

antique wood

GRANITOKER



antique black cm 20x120 - 7⁷/₈"x47¹/₄"

COLORI COLOURS COULEURS FARBEN

antique black





antique moka

antique white

FORMATI SIZES FORMATS FORMATE

antique wood GRANITOKER

Formati Sizes Formats Formate		
	cm 15x120 5 ⁷ / ₈ "x47 ¹ / ₄ "	cm 20x120 7 ⁷ / ₈ "x47 ¹ / ₄ "
Superfici Surfaces Surfaces Oberflächen	●	●
Spessori Thicknesses Epaisseurs Stärken	mm 10	mm 10
● Naturale Matt Naturelle Matt R10 A+B	 Caratteristiche tecniche e imballi a pagina Technical features and packing on page Caractéristiques techniques et emballages à la page Technische Eigenschaften und Verpackungen auf Seite 450	
	Accentuata Accentuated Forte Akzentuiert	

PEZZI SPECIALI TRIMS ACCESSOIRES FORMSTÜCKE

Battiscopa Bullnose
Plinthe à bord arrondi Stehsockel
 cm 9x120 - 3¹/₂"x47¹/₄"



Gradino Step tread
Nez de marche Stufenplatte
 cm 30x120 - 11³/₄"x47¹/₄"



Gradone (assemblato)
 cm 120x33 - 47¹/₄"x13"

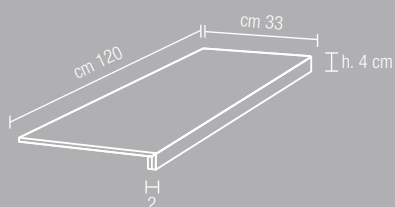

Angolare (assemblato)
 cm 120x33 - 47¹/₄"x13"

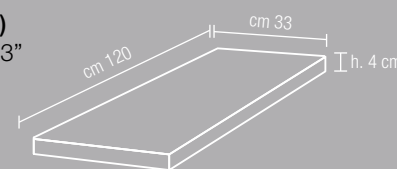

DECORI DECORS DÉCORS DEKORE

listone antique*



cm 20x120 - 77/8"x471/4"

* Disponibile in tutti i colori della serie.
Available in all the colours of the series.
Disponible dans tous les couleurs de la série.
Verfügbar in allen Farben.

DECORI DECORS DÉCORS DEKORE

antique wood

GRANITOKER

chevron A*



cm 31x29,5 - 12¹/₄"x11⁵/₈" **dx / sx**
su rete on net sur trame auf Netz

listelli antique*



cm 30x30 - 11³/₄"x11³/₄"
 listello cm 1,4x30 - 1/2"x11³/₄"
su rete on net sur trame auf Netz

chevron B*

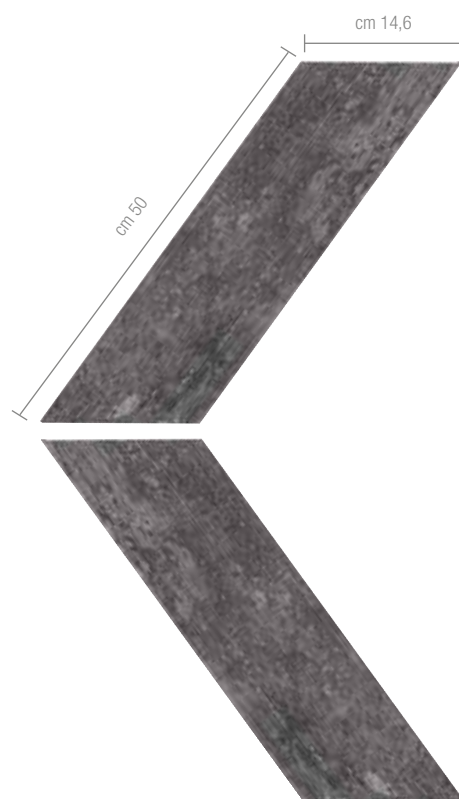

cm 14,6x50 - 5³/₄"x19³/₄" **dx / sx**

* Disponibile in tutti i colori della serie.
 Available in all the colours of the series.
 Disponible dans tous les couleurs de la série.
 Verfügbar in allen Farben.



listone antique white cm 20x120 - 7⁷/₈"x47¹/₄"
 antique white cm 20x120 - 7⁷/₈"x47¹/₄"



chevron A antique black cm 31x29,5 - 12¹/₄"x11⁵/₈"

tavolato

GRANITOKER

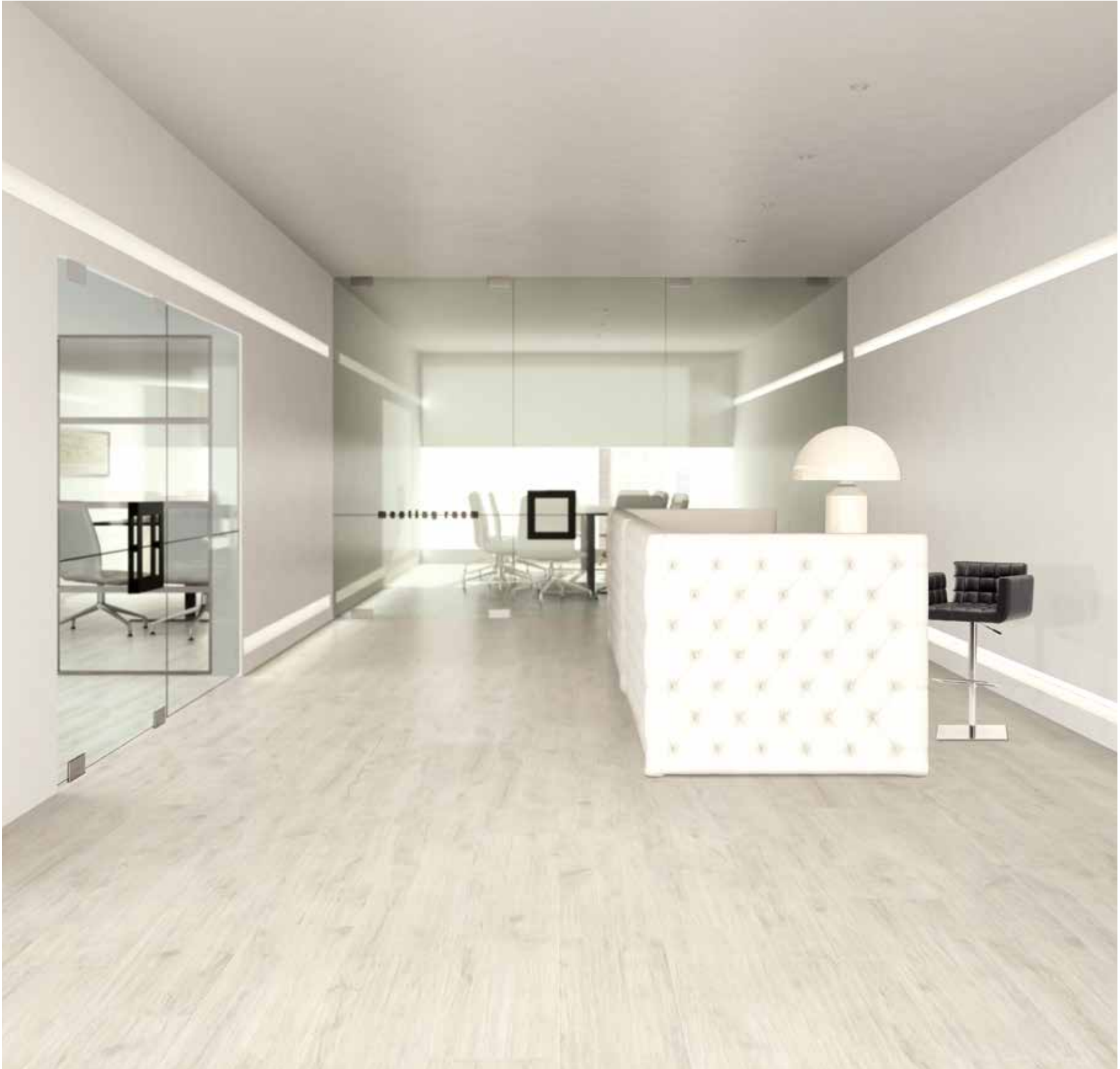

sbiancato cm 15x120 - 57/8"x47 1/4", 20x120 - 77/8"x47 1/4", 30x120 - 11 3/4"x47 1/4"

COLORI COLOURS COULEURS FARBEN

antracite



marrone scuro



marrone medio



marrone chiaro



grano



FORMATI SIZES FORMATS FORMATE

tavolato
GRANITOKER

sbiancato



Formati Sizes Formats Formate	cm 15x60 5 ⁷ / ₈ "x23 ⁵ / ₈ "	cm 15x90 5 ⁷ / ₈ "x35 ³ / ₈ "	cm 15x120 5 ⁷ / ₈ "x47 ¹ / ₄ "	cm 20x120 7 ⁷ / ₈ "x47 ¹ / ₄ "	cm 30x120 11 ³ / ₄ "x47 ¹ / ₄ "
Superfici Surfaces Surfaces Oberflächen	●	●	●	●	●
Spessori Thicknesses Epaisseurs Stärken	mm 8,5*	mm 8,5*	mm 10,5	mm 10,5	mm 10,5

- Naturale Matt Naturelle Matt **R9**

* Non rettificato. Unrectified. Non rectifié. Nicht kalibriert.

Le piastrelle della serie Tavolato sono fornite rettificate in un unico calibro.
Su richiesta possono essere forniti tutti i formati ottenuti per taglio.
The tiles in the Tavolatoseries come in a single caliber, rectified version.
All sizes obtained by cutting can be supplied on request.
Les carreaux de la série Tavolato sont fournis rectifiés en un unique calibre.
Sur demande peuvent être fournis tous les formats, obtenus par découpe.
Die Fliesen der Serie Tavolato werden in einem einzigen Werkmass maßgeschliffen geliefert.
Auf Anfrage können alle Formate geschnitten und geliefert werden.



Accentuata
Accentuated
Forte
Akzentuiert

Caratteristiche tecniche e imballi a pagina
Technical features and packing on page
Caractéristiques techniques et emballages à la page
Technische Eigenschaften und Verpackungen auf Seite
450

PEZZI SPECIALI TRIMS ACCESSOIRES FORMSTÜCKE

Battiscopa Bullnose
Plinthe à bord arrondi Stehsockel
cm 9x120 - 3¹/₂"x47¹/₄"
cm 7,5x60 - 3"x23⁵/₈"



Gradino Step tread
Nez de marche Stufenplatte
cm 30x120 - 11³/₄"x47¹/₄"

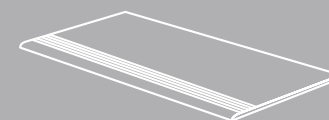

Gradone (assemblato)
cm 120x33 - 47¹/₄"x13"

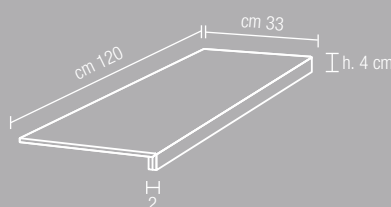

Angolare (assemblato)
cm 120x33 - 47¹/₄"x13"

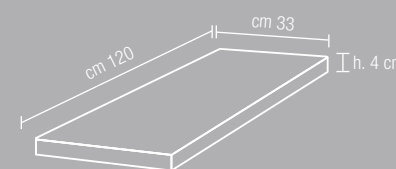

DECORI DECORS DÉCORS DEKORE

listelli*



cm 30x30 - 11³/₄"x11³/₄"
listello cm 1,4x30 - 1/2"x11³/₄"
su rete on net sur trame auf Netz

quadrotte*



cm 30x30 - 11³/₄"x11³/₄"
su rete on net sur trame auf Netz

cassettone 3D**



cm 29,5x29,5 - 11⁵/₈"x11⁵/₈"
F Tavolato Marrone Scuro +
Marmoker Birimbau lucida

cassettone tavolato A*



cm 60x60 - 23⁵/₈"x23⁵/₈"

chevron A*

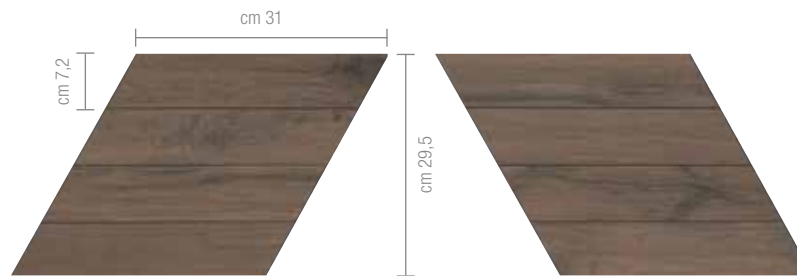

cm 31x29,5 - 12¹/₄"x11⁵/₈" **dx / sx**
su rete on net sur trame auf Netz

chevron B*



cm 14,6x50
5³/₄"x19³/₄" **dx / sx**

* Disponibile in tutti i colori della serie.
Available in all the colours of the series.
Disponibile dans toutes les couleurs de la série.
Verfügbar in allen Farben.

tavolato

GRANITOKER

cassettone tavolato A marrone scuro cm 60x60 - 23⁵/₈"x23⁵/₈",
marrone scuro cm 15x120 - 5⁷/₈"x47¹/₄", 20x120 - 7⁷/₈"x47¹/₄", 30x120 - 11³/₄"x47¹/₄"

ulivo
GRANITOKER



noce cm 15x120 - 5⁷/₈"x47¹/₄", 20x120 - 7⁷/₈"x47¹/₄", 30x120 - 11³/₄"x47¹/₄"

COLORI COLOURS COULEURS FARBEN

grigio

tortora

noce

panna





ulivo
GRANITOKER



tortora cm 20x120 - 77/8"x47 1/4"

FORMATI SIZES FORMATS FORMATE

Formati Sizes Formats Formate			
	cm 15x120 57/8"x47 1/4"	cm 20x120 77/8" x47 1/4"	cm 30x120 11 3/4"x47 1/4"
Superfici Surfaces Surfaces Oberflächen	●	●	●
Spessori Thicknesses Epaisseurs Stärken	mm 10	mm 10	mm 10
● Naturale Matt Naturelle Mattt R10	 <p>Accentuata Accentuated Forte Akzentuiert</p>		
	<p>Caratteristiche tecniche e imballi a pagina Technical features and packing on page Caractéristiques techniques et emballages à la page Technische Eigenschaften und Verpackungen auf Seite 450</p>		

PEZZI SPECIALI TRIMS ACCESSOIRES FORMSTÜCKE

Battiscopa Bullnose
Plinthe à bord arrondi Stehsockel
cm 9x120 - 3 1/2"x47 1/4"



Gradino Step tread
Nez de marche Stufenplatte
cm 30x120 - 11 3/4"x47 1/4"

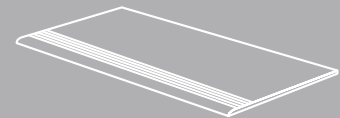

Gradone (assemblato)
cm 120x33 - 47 1/4"x13"

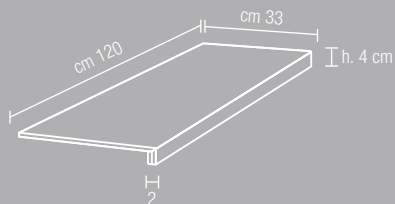

Angolare (assemblato)
cm 120x33 - 47 1/4"x13"

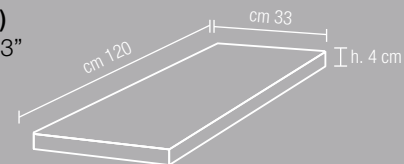

DECORI DECORS DÉCORS DEKORE

ulivo
GRANITOKER

listelli ulivo*



cm 30x30 - 11³/₄"x11³/₄"
listello cm 1,4x30 - 1/2"x11³/₄"
su rete on net sur trame auf Netz

chevron A*

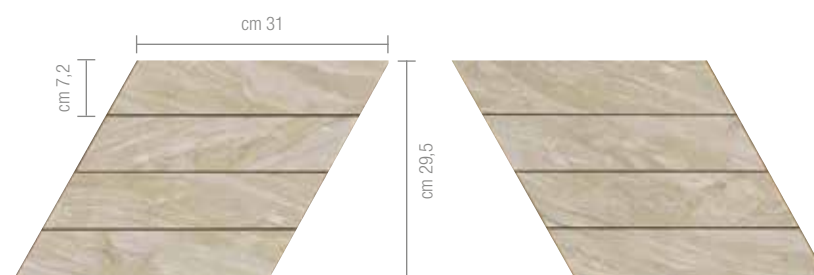

cm 31x29,5 - 12¹/₄"x11⁵/₈" **dx / sx**
su rete on net sur trame auf Netz

quadrotte ulivo*



cm 30x30 - 11³/₄"x11³/₄"
su rete on net sur trame auf Netz

chevron B*

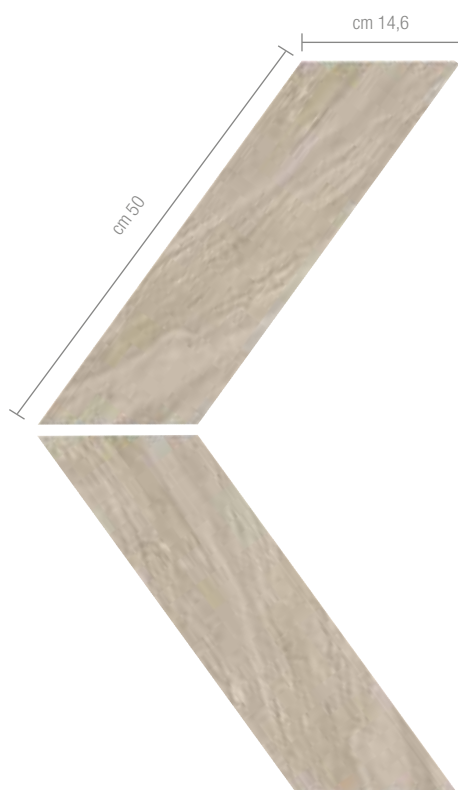

cm 14,6x50 - 5³/₄"x19³/₄" **dx / sx**

cassettone 3D**



cm 29,5x29,5 - 11⁵/₈"x11⁵/₈"

* Disponibile in tutti i colori della serie.
Available in all the colours of the series.
Disponibile dans toutes les couleurs de la série.
Verfügbar in allen Farben.

** **A** Ulivo Noce + Marmoker Asiago *lucida*
B Ulivo Noce + Marmoker Statuario Oro *lucida*
C Ulivo Noce + Marmoker Travertino Noce *lucida*
D Ulivo Noce + Marmoker Crema Select *lucida*
E Ulivo Noce + Marmoker Breccia Argento *lucida*
G Ulivo Grigio + Marmoker Bardiglio Imperiale *lucida*
H Ulivo Grigio + Marmoker Statuario Grigio *lucida*
I Ulivo Grigio + Marmoker Bardiglio Bianco *lucida*
L Ulivo Grigio + Marmoker Olimpo *lucida*
M Ulivo Noce + Ulivo Panna



cassettone 3D
cm 29,5x29,5 - 11⁵/₈"x11⁵/₈"

newood
GRANITOKER



ivory cm 15x90 - 5⁷/₈"x35³/₈"

COLORI COLOURS COULEURS FARBEN

black



grey



wengé



brown



cream



newood
GRANITOKER

beige

ivory

white



grey cm 11x90 - 4³/₈"x35³/₈", 15x90 - 5⁷/₈"x35³/₈"

FORMATI SIZES FORMATS FORMATE

Formati Sizes Formats Formate	cm 11x90 4 ¹ / ₈ "x35 ³ / ₈ "	cm 15x90 5 ⁷ / ₈ "x35 ³ / ₈ "	cm 22,5x90 8 ⁷ / ₈ "x35 ³ / ₈ "	cm 45x90 17 ³ / ₄ "x35 ³ / ₈ "	cm 15x120 5 ⁷ / ₈ "x47 ¹ / ₄ "	cm 20x120 7 ⁷ / ₈ "x47 ¹ / ₄ "
Superfici Surfaces Surfaces Oberflächen	● ●*	●	●	●	● ●*	● ●*
Spessori Thicknesses Epaisseurs Stärken	mm 10,5	mm 10,5	mm 10,5	mm 10,5	mm 10,5	mm 10,5

- Naturale Matt Naturelle Matt **R 10 A+B**
- Outdoor **R 11 A+B+C**

* Disponibile nei colori: Available in the colours:
 Disponible dans les couleurs: Verfügbar in den folgenden Farben:
brown, cream, grey, wengé.

Altri colori sono prodotti solo su richiesta.
 Other colours are produced on demand only.
 Autres teintes disponibles sur demande.
 Andere Farben nur auf Anfrage.



Media
 Medium
 Moyenne
 Mittel

Caratteristiche tecniche e imballi a pagina
 Technical features and packing on page
 Caractéristiques techniques et emballages à la page
 Technische Eigenschaften und Verpackungen auf Seite
450

PEZZI SPECIALI TRIMS ACCESSOIRES FORMSTÜCKE

Battiscopa Bullnose
Plinthe à bord arrondi Stehsockel
 cm 9x90 - 3¹/₂"x35³/₈"
 cm 9x120 - 3¹/₂"x47¹/₄"



Gradino Step tread
Nez de marche Stufenplatte
 cm 30x120 - 11³/₄"x47¹/₄"



Gradone (assemblato)
 cm 120x33 - 47¹/₄"x13"

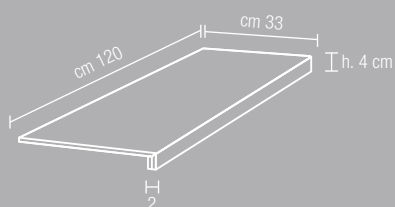

Angolare (assemblato)
 cm 120x33 - 47¹/₄"x13"

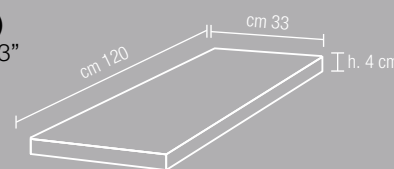

SUPERFICI SURFACES SURFACES OBERFLÄCHEN

newood
GRANITOKER

naturale matt naturelle matt R10 A+B

outdoor R11 A+B+C

DECORI DECORS DÉCORS DEKORE

mix listelli newood A*



cm 30x30 - 11³/₄"x11³/₄"
su rete on net sur trame auf Netz
black, grey, white

mix listelli newood B*



cm 30x30 - 11³/₄"x11³/₄"
su rete on net sur trame auf Netz
ivory, beige, cream

mix listelli newood C*



cm 30x30 - 11³/₄"x11³/₄"
su rete on net sur trame auf Netz
**wengé, brown, cream,
 beige, ivory**

listoni newood**



cm 15x90 - 5⁷/₈"x35³/₈"
su rete on net sur trame auf Netz

listelli newood**

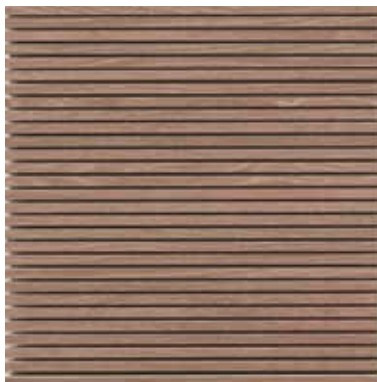

cm 30x30 - 11³/₄"x11³/₄"
su rete on net sur trame auf Netz

* La dimensione delle tessere e la distribuzione dei colori è casuale.
 The dimension of the pieces and the distribution of the colours are random.
 La dimension des tesselles et la distribution des couleurs est casuelle.
 Die Abmessung der Steine und die Farbenverteilung sind zufällig.

** Disponibile in tutti i colori della serie.
 Available in all the colours of the series.
 Disponible dans tous les couleurs de la série.
 Verfügbar in allen Farben.

newood

GRANITOKER

listoni mix newood A



cm 15x90 - 5⁷/₈"x35³/₈"
su rete on net sur trame auf Netz **black, grey**

listoni mix newood B



cm 15x90 - 5⁷/₈"x35³/₈"
su rete on net sur trame auf Netz **white, grey**

listoni mix newood C



cm 15x90 - 5⁷/₈"x35³/₈"
su rete on net sur trame auf Netz **ivory, beige**

listoni mix newood D

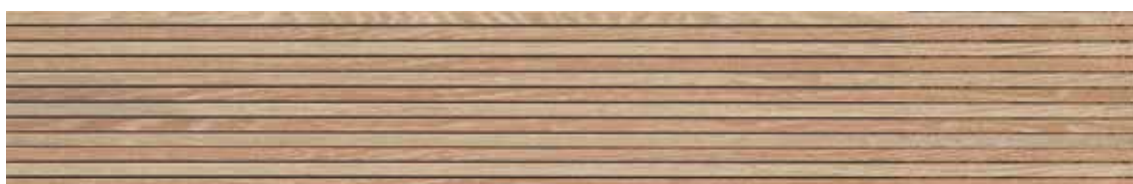

cm 15x90 - 5⁷/₈"x35³/₈"
su rete on net sur trame auf Netz **cream, brown**

listoni mix newood E



cm 15x90 - 5⁷/₈"x35³/₈"
su rete on net sur trame auf Netz **wengé, beige**



mix listelli newood A
 cm 30x30 - 11³/₄"x11³/₄",
black cm 11x90 - 4³/₄"x35³/₈",
 15x90 - 5⁷/₈"x35³/₈", 45x90 - 17³/₄"x35³/₈"



listoni newood cream
 cm 15x90 - 5⁷/₈"x35³/₈",
wengé cm 15x90 - 5⁷/₈"x35³/₈"

metalwood

GRANITOKER

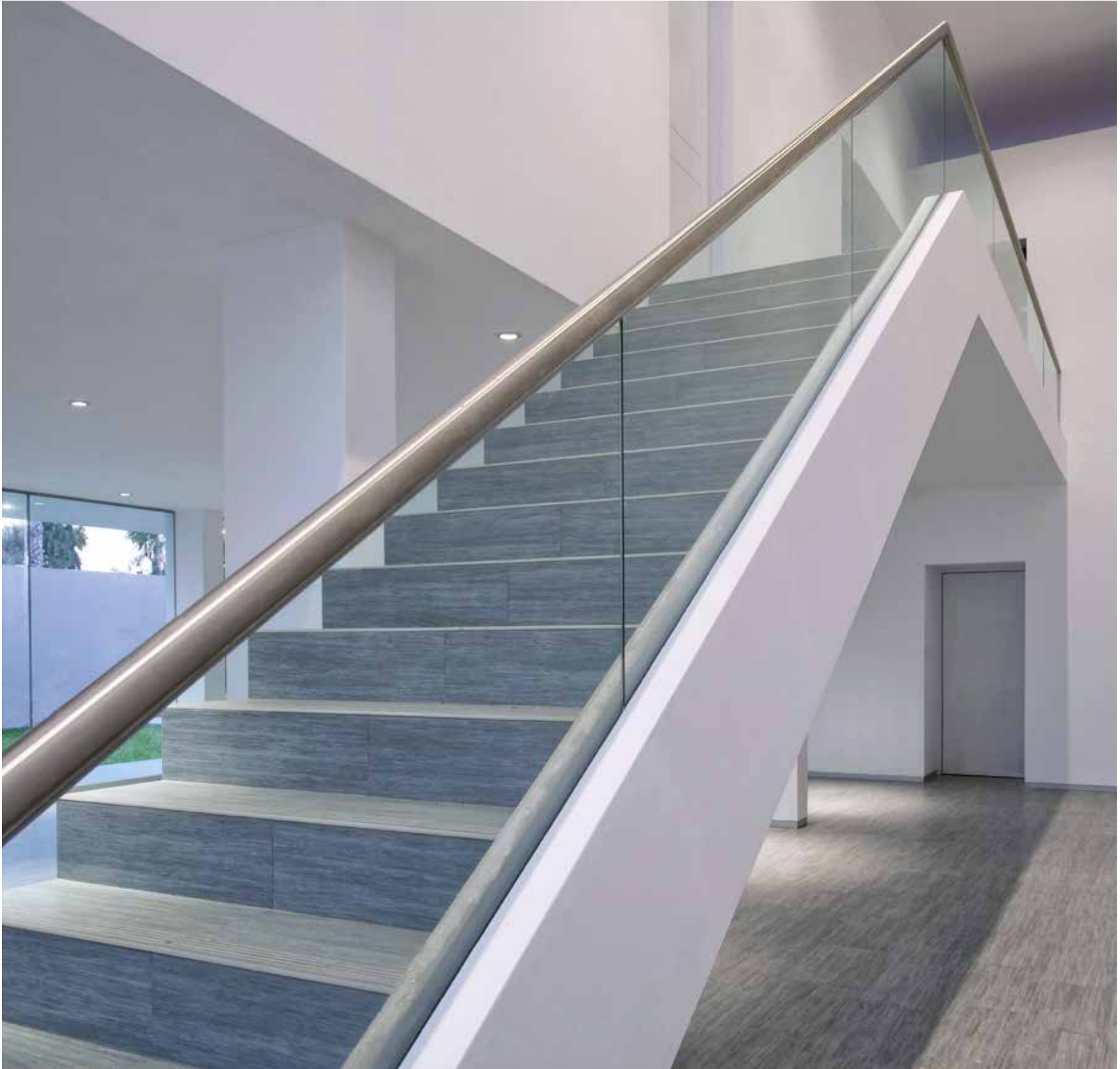

piombo cm 30x60 - 11³/₄"x23⁵/₈"

COLORI COLOURS COULEURS FARBEN

carbonio

silicio

bronzo

piombo

argento



metalwood

GRANITOKER







iridio

platino



iridio cm 60x120 - 23⁵/₈"x47¹/₄"

FORMATI SIZES FORMATS FORMATE

							
Formati Sizes Formats Formate	cm 10x60 4"x23 ⁵ / ₈ "	cm 30x60 11 ³ / ₄ "x23 ⁵ / ₈ "	cm 60x60 23 ⁵ / ₈ "x23 ⁵ / ₈ "	cm 15x90 5 ⁷ / ₈ "x35 ³ / ₈ "	cm 45x90 17 ³ / ₄ "x35 ³ / ₈ "	cm 15x120 5 ⁷ / ₈ "x48"	cm 20x120 7 ⁷ / ₈ "x47 ¹ / ₄ "
Superfici Surfaces Surfaces Oberflächen	●	●	●	●	●	●	●
Spessori Thicknesses Épaisseurs Stärken	mm 9,4	mm 9,4	mm 10,5	mm 10,5	mm 10,5	mm 10,5	mm 10,5

- **Naturale Matt Naturelle Matt R9 A**

Altri formati sono ottenibili da taglio su richiesta.
Other sizes can be obtained by cutting on request.
Les autres formats peuvent être obtenus par découpe sur demande.
Andere Formate werden mit dem Schnitt erzielt auf Anfrage.

Le piastrelle della serie Metalwood sono fornite rettificate in un unico calibro.
The tiles in the Metalwood series come in a single caliber, rectified version.
Les carreaux de la série Metalwood sont fournis rectifiés en un unique calibre.
Die Fliesen der Serie Metalwood werden in einem einzigen Werkmass massgeschliffen geliefert.

Nel caso di combinazioni di formati di spessori diversi, specificarlo espressamente nell'ordine.
Please specify in your order if you wish to purchase formats including more than one thickness.
Prière de spécifier dans votre commande si vous souhaitez acheter des formats avec différentes épaisseurs.
Bitte weisen Sie im Bestellungsformular ausdrücklich darauf hin, wenn Sie Formatkombinationen mit verschiedenen Stärken wünschen.



Media
Medium
Moyenne
Mittel

Caratteristiche tecniche e imballi a pagina
Technical features and packing on page
Caractéristiques techniques et emballages à la page
Technische Eigenschaften und Verpackungen auf Seite
450

PEZZI SPECIALI TRIMS ACCESSOIRES FORMSTÜCKE

Battiscopa Bullnose
Plinthe à bord arrondi Stehsockel
cm 9x60 - 3¹/₂"x23⁵/₈"
cm 9x90 - 3¹/₂"x35³/₈"



Gradino Step tread
Nez de marche Stufenplatte
cm 30x60 - 11³/₄"x23⁵/₈"

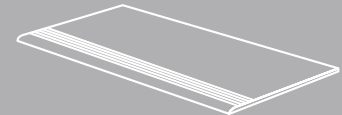

Gradone (assemblato)*
cm 60x33 - 23⁵/₈"x13"
cm 120x33 - 48"x13"

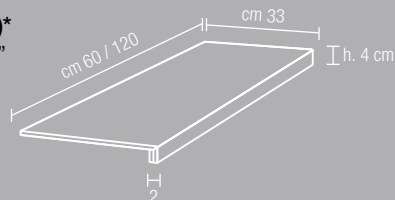

Angolare (assemblato)*
cm 60x33 - 23⁵/₈"x13"
cm 120x33 - 48"x13"

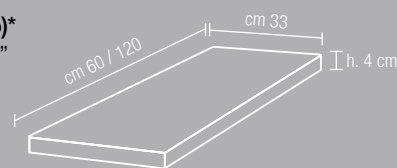

Tozzetto Insert
Cabochon Einleger
cm 10x10 4"x4"



* Disponibile nei colori Available in the colours Disponible dans les couleurs Verfügbar in den folgenden Farben: **Platino, Iridio, Argento, Piombo.**
Altri colori sono prodotti solo su richiesta. Other colours are produced on demand only. Autres teintes disponibles sur demand. Andere Farben nur auf Anfrage.

DECORI DECORS DÉCORS DEKORE

metalwood
GRANITOKER

mix listelli A



cm 30x30 - 11³/₄"x11³/₄"
listello cm 1,4x30 - 1/2"x11³/₄"
su rete on net sur trame auf Netz
silicio, piombo, argento

mix listelli B



cm 30x30 - 11³/₄"x11³/₄"
listello cm 1,4x30 - 1/2"x11³/₄"
su rete on net sur trame auf Netz
bronzo, argento, iridio

mix listelli C



cm 30x30 - 11³/₄"x11³/₄"
listello cm 1,4x30 - 1/2"x11³/₄"
su rete on net sur trame auf Netz
argento, piombo, platino

mosaico listelli*



cm 30x30 - 11³/₄"x11³/₄"
su rete on net sur trame auf Netz

fascia metalwood*



cm 10x60 - 4"x23⁵/₈"

* Disponibile in tutti i colori della serie.
Available in all the colours of the series.
Disponibile dans tous les couleurs de la série.
Verfügbar in allen Farben.



iridio cm 30x60 - 11³/₄"x23⁵/₈"



mix listelli A cm 30x30 - 11³/₄"x11³/₄"



parchi
GRESPLUS



sequoia cm 41,5x41,5 - 16³/₈"x 16³/₈"

COLORI COLOURS COULEURS FARBEN



sequoia



yellowstone



FORMATI SIZES FORMATS FORMATE

Formati Sizes Formats Formate	 cm 41,5x41,5 16 ^{3/8} "x16 ^{3/8} "	 cm 60x60 23 ^{5/8} "x23 ^{5/8} "
Sequoia G4*	●	●
Yellowstone G4*	●	●
Spessori Thicknesses Epaisseurs Stärken	mm 8,8	mm 20
● Naturale Matt Naturelle Matt	R10	R11 A+B+C

* Vedi pagina See page
Voire page Siehe Seite
453



Accentuata
Accentuated
Forte
Akzentuiert

Caratteristiche tecniche e imballi a pagina
Technical features and packing on page
Caractéristiques techniques et emballages à la page
Technische Eigenschaften und Verpackungen auf Seite
452

parchi

GRESPLUS



yellowstone cm 60x60 - 23⁵/₈"x23⁵/₈"

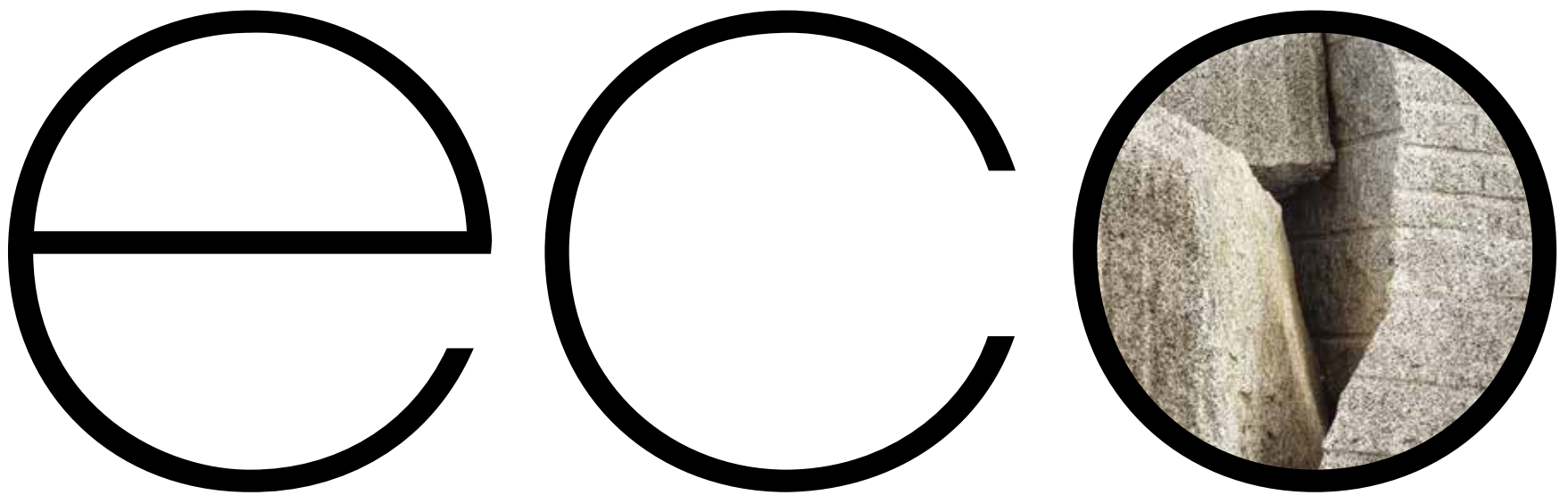

eco**granite** éco**granit** öko**granit**

granito

eco**granito**

- 290 **granito 1evo**
- 294 **granito 1**
- 302 **granito 2**
- 308 **granito 3**
- 314 **granito 4**

GRANITO

Roccia fanero cristallina da costruzione e decorazione, compatta e lucidabile, prevalentemente costituita da minerali di durezza Mohs da 6 a 7, come i quarzi, i feldspati e i feldspatoidi. In funzione della loro composizione possono essere distinti: i graniti propriamente detti [rocce magmatiche intrusive acide fanero-cristalline, costituite da quarzo, feldspati sodico potassici e miche]; altre rocce magmatiche intrusive (dioriti, granodioriti, sieniti, gabbri eccetera); rocce magmatiche effusive a struttura porfirica; alcune rocce metamorfiche di analoga composizione come gneiss e serizzi.

GRANITE

Crystalline phaneritic rock for decorative and building purposes. It is compact, can be polished and mainly consists of minerals with 6 to 7 Mohs hardness such as quartzes, feldspars and feldspathoids. Depending on their composition, granites include: granite in the strict sense of the term [phaneritic-crystalline intrusive magmatic acid rocks consisting of quartz, soda potash feldspars and micas]; other intrusive magmatic rocks (diorites, granodiorites, syenites, gabbros, etc); magmatic effusive rock with a porphyritic structure; certain metamorphic rocks of similar composition, such as gneiss and paragneiss.

granito 1evo

GRANITOGRES



denver cm 30x30 - 11³/₄"x11³/₄"

COLORI COLOURS COULEURS FARBEN

new york

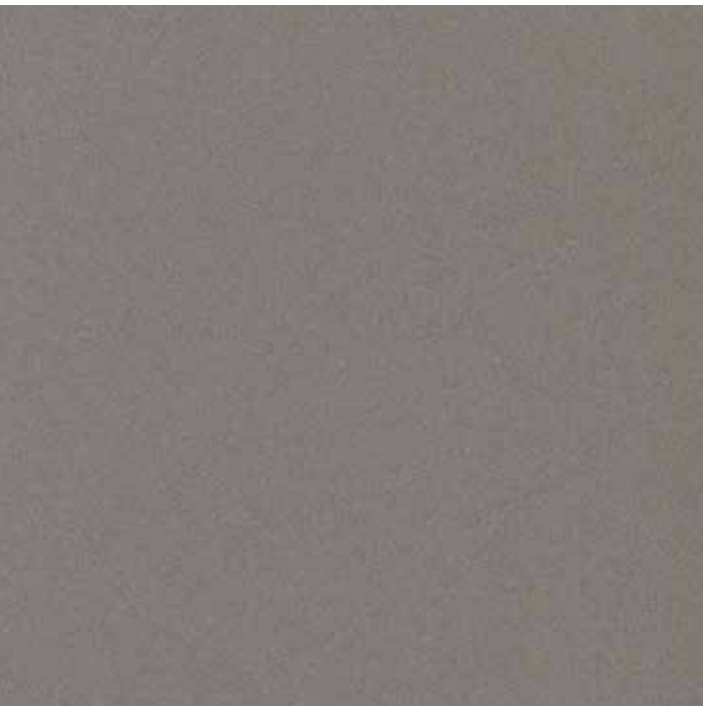

chicago



denver



seattle

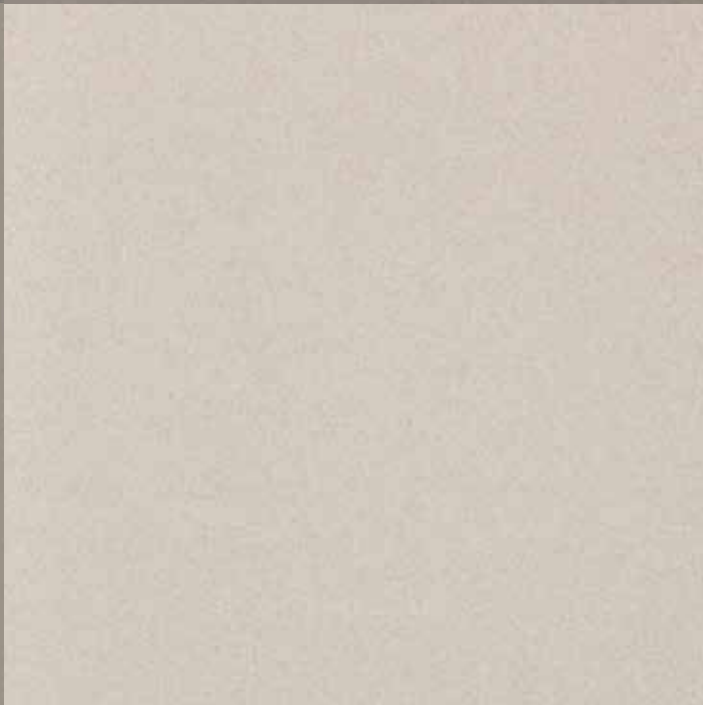





tucson



boston

FORMATI SIZES FORMATS FORMATE

granito 1evo
GRANITOGRES

Formati Sizes Formate Formats	 cm 30x30 11 ³ / ₄ "x11 ³ / ₄ "	 cm 45x45 17 ³ / ₄ "x17 ³ / ₄ "	 cm 30x60 11 ³ / ₄ "x23 ⁵ / ₈ "	 cm 60x60 23 ⁵ / ₈ "x23 ⁵ / ₈ "
Superfici Surfaces Surfaces Oberflächen	● ●	●	●	●
Spessori Thicknesses Epaisseurs Stärken	mm 7,6	mm 9	mm 9	mm 10

- Naturale Matt Naturelle Matt **R10 A**
- Secura **R11 (A+B)**



Uniforme
Uniform
Uniforme
Einheitlich

Caratteristiche tecniche e imballi a pagina
Technical features and packing on page
Caractéristiques techniques et emballages à la page
Technische Eigenschaften und Verpackungen auf Seite
444

PEZZI SPECIALI TRIMS ACCESSOIRES FORMSTÜCKE

Battiscopa Bullnose
Plinthe à bord arrondi Stehsockel
cm 9x45 - 3¹/₂"x17³/₄"
cm 9x30 - 3¹/₂"x11³/₄"



Gradino Step tread
Nez de marche Stufenplatte
cm 30x30 - 11³/₄"x11³/₄"

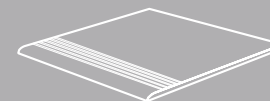

Zoccolo a raccordo a taglio retto
Cove base - straight top
Plinthe à gorge avec bord vif
Hohlkehlssockel (scharfkantig)
cm 10x30 - 4"x11³/₄"

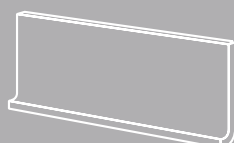

Zoccolo ad appoggio smussato
Sit-on skirting - bevelled top
Plinthe à talon avec bord arrondi
Aufsetzsockel mit abgerundeter Kante
cm 10x30 - 4"x11³/₄"

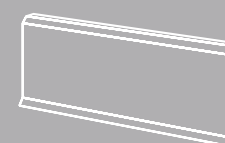

granito 1

GRANITOGRES

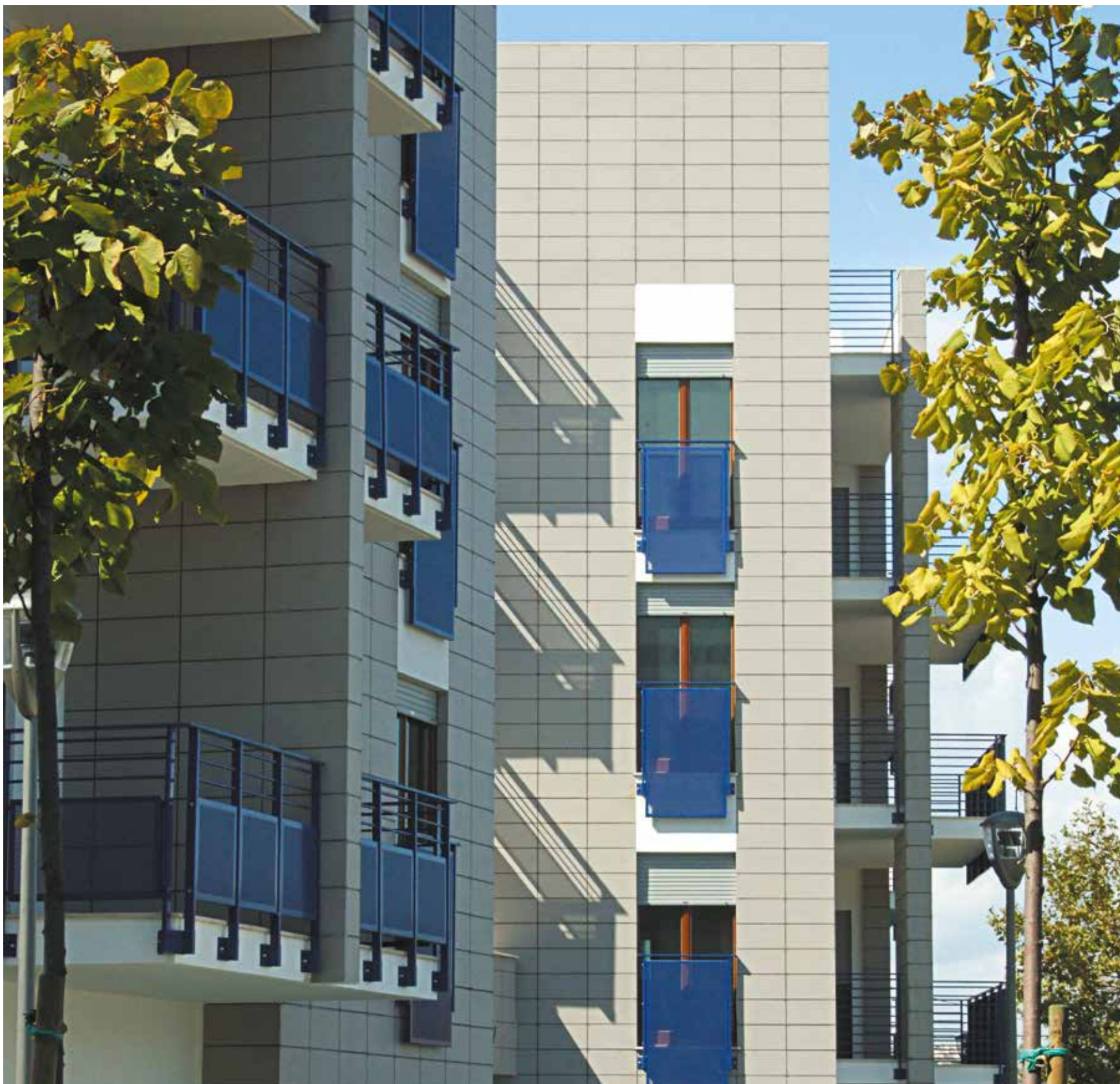

nebraska cm 30x60 - 11³/₄"x23⁵/₈"

COLORI COLOURS COULEURS FARBEN

dakota



ontario

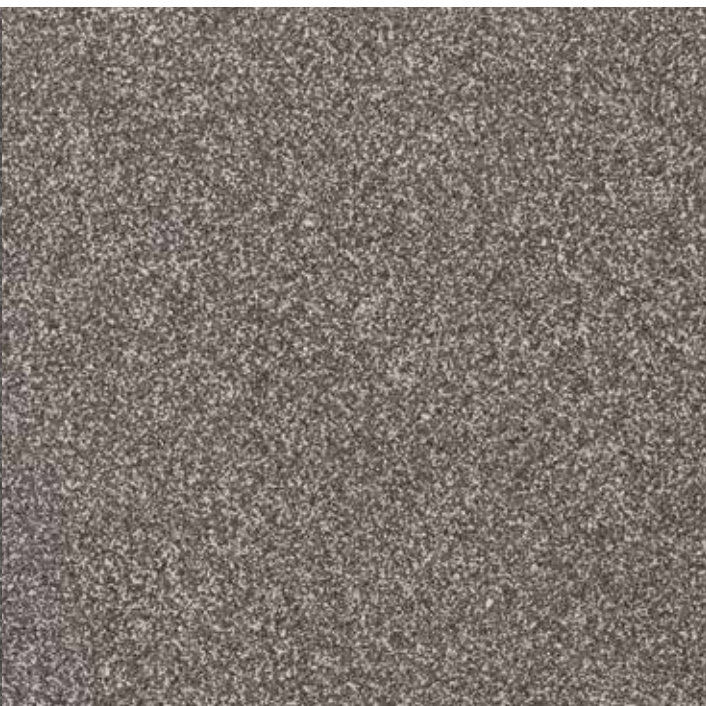

giamaica



arizona



arkansas



sahara

granito 1

GRANITOGRES

minnesota

georgia

labrador

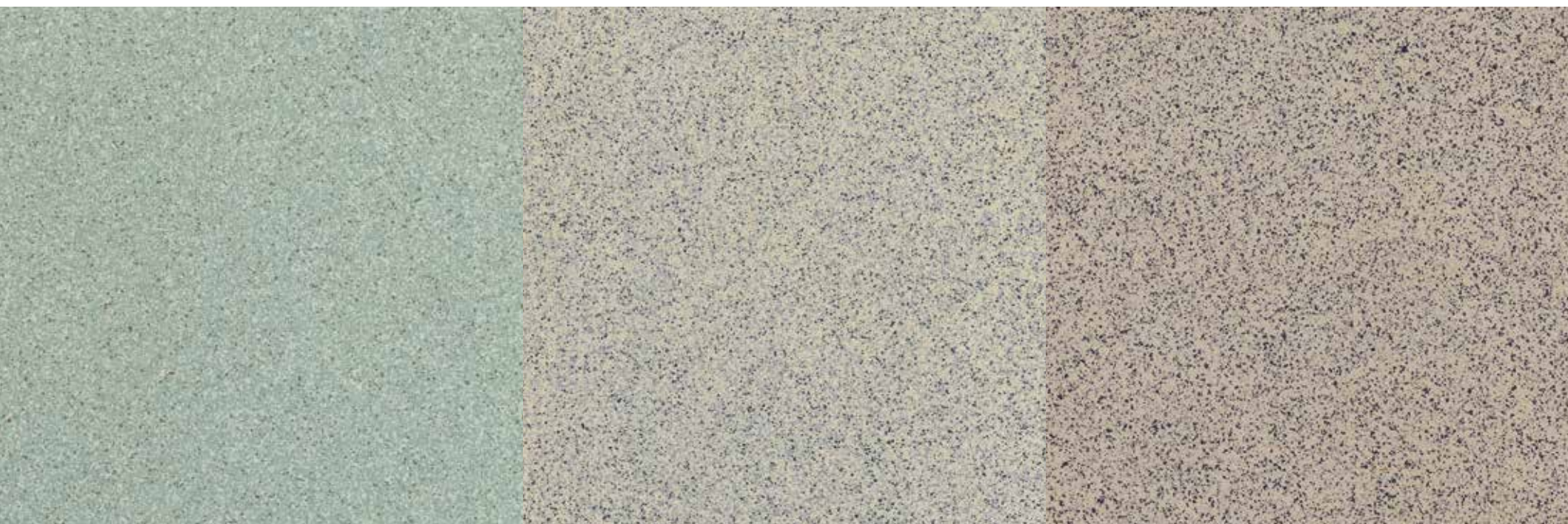

everest

nebraska

nevada

COLORI COLOURS COULEURS FARBEN

marocco



colorado

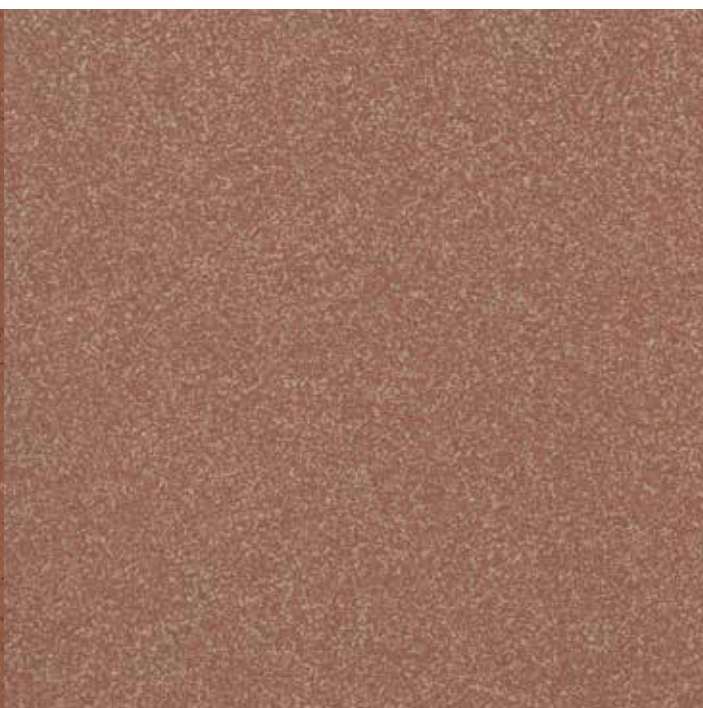

iberia



terranova



tibet



catalogna







SUPERFICI **SURFACES** SURFACES OBERFLÄCHEN

granito 1
GRANITOGRES

levigata polished polie poliert

naturale matt naturelle matt R9A

FORMATI SIZES FORMATS FORMATE

Formati Sizes Formats Formate	 cm 15x15 5 ^{7/8} "x5 ^{7/8} "	 cm 10x20 4"x7 ^{7/8} "	 cm 20x20 7 ^{7/8} "x7 ^{7/8} "	 cm 12,5x25 4 ^{7/8} "x9 ^{7/8} "	 cm 30x30 11 ^{3/4} "x11 ^{3/4} "	 cm 40x40 15 ^{3/4} "x15 ^{3/4} "
Arizona			●		● ●	● ●
Arkansas	● ●	●	● ●	●	● ● ●	● ●
Catalogna			●		● ●	● ●
Colorado	● ●	●	● ●	●	● ● ●	● ●
Dakota			●		● ●	● ●
Everest			●		● ●	● ●
Georgia	● ●	●	● ●	●	● ● ●	● ●
Giamaica			●		● ●	● ●
Iberia			●		● ●	● ●
Labrador	● ●	●	● ●	●	● ● ●	● ●
Marocco			●		● ●	● ●
Minnesota			●		● ●	● ●
Nebraska	● ●	●	● ●	●	● ● ●	● ●
Nevada			●		● ●	● ●
Ontario	● ●	●	● ●	●	● ● ●	● ●
Sahara	● ●	●	● ●	●	● ● ●	● ●
Terranova			●		● ●	● ●
Tibet			●		● ●	● ●
Spessori* Thicknesses* Epaisseurs* Stärken*	mm 8	mm 8	mm 8	mm 8	mm 8	mm 9

- Naturale Matt Naturelle Matt **R9 A**
- Levigata Polished Polie Poliert
- Technic **R10**

* Spessore su superficie naturale.
Thickness on matt surface.
Épaisseur sur surface naturelle.
Stärke der Fliesen mit Mattoberfläche.



Uniforme
Uniform
Uniforme
Einheitlich

Caratteristiche tecniche e imballi a pagina
Technical features and packing on page
Caractéristiques techniques et emballages à la page
Technische Eigenschaften und Verpackungen auf Seite
444

Per superfici speciali antiscivolo e spessori maggiorati vedere collezione Technic a pag XXX
For increased thicknesses and special no-slip surfaces see the Technic collection on page XXX.
Pour des surfaces antiderapantés et les épaisseurs majorés, voir collection Technic à la page XXX
Für sonderrutschhemmende Oberflächen und Stärken siehe Kollektion Technic auf Seite XXX

FORMATI SIZES FORMATS FORMATE

granito 1
GRANITOGRES

PEZZI SPECIALI TRIMS ACCESSOIRES FORMSTÜCKE

Battiscopa Bullnose
Plinthe à bord arrondi Stehsockel

cm 9x30 - 3½"x11¾"
cm 9x40 - 3½"x15¾"
cm 10x20 - 4"x7⅞"



Gradino Step tread
Nez de marche Stufenplatte

cm 30x30 - 11¾"x11¾"

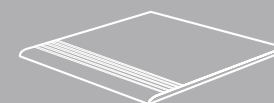

Tozzetto Insert
Cabochon Einleger

cm 9x9 - 3½"x 3½"



*** Zoccolo a raccordo a taglio retto**
Cove base - straight top
Plinthe à gorge avec bord vif
Hohlkehlssockel (scharfkantig)

cm 10x20 - 4"x7⅞"

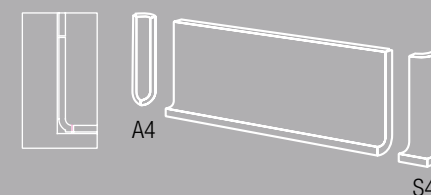

Listello Listel
Listel Zeierleiste

cm 9x30 - 3½"x11¾"
cm 9x40 - 3½"x15¾"



*** Zoccolo ad appoggio smussato**
Sit-on skirting - bevelled top
Plinthe à talon avec
bord arrondi
Aufsetzsockel mit
abgerundeter Kante

cm 10x20 - 4"x7⅞"

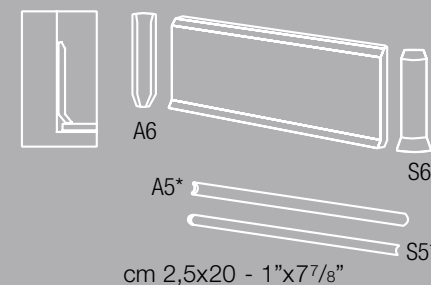

***Sguscetta *Cove**
***Gorge *Rinnleiste**

cm 4x20 - 1⅝"x7⅞"

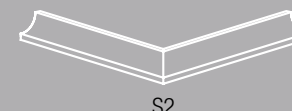
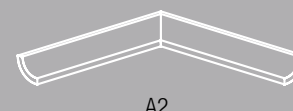

Terminale Step tread
Rebord Bechkenrandplatte

cm 30x30 - 11¾"x11¾"



* Produzione corrente solo nei colori:

Currently produced only in the following colours:

Productions courantes seulement dans les couleurs:

Actuelle Produktion nur in den Farben:

Arkansas, Colorado, Georgia, Labrador, Nebraska, Ontario, Sahara

Altri colori sono prodotti solo su richiesta.

Other colours are produced on demand.

Autres teintes disponibles sur demande.

Andere Farben nur auf Anfrag.

granito 2

GRANITOGRES



genova, milano, granito 3 ankara, tactile cm 30x30 - 11³/₄"x11³/₄"

COLORI COLOURS COULEURS FARBEN

milano



venezia



cortina



torino

genova

siena

granito 2

GRANITOGRES

cervinia

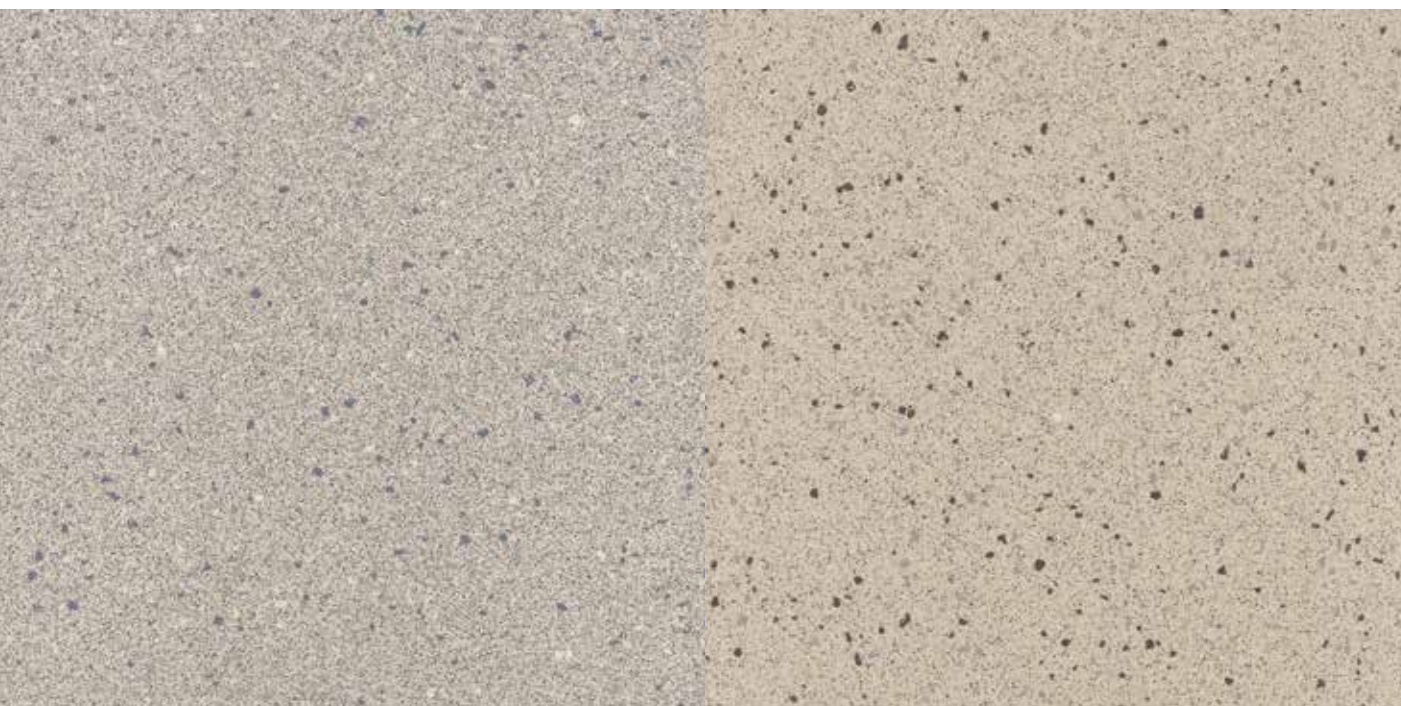

amalfi



gallipoli

cortina cm 30x30 - 11³/₄"x11³/₄"



granito 2 genova, milano
granito 3 ankara
cm 30x30 - 11³/₄"x11³/₄"

FORMATI SIZES FORMATS FORMATE

Formati Sizes
Formats Formate



cm 30x30
11³/₄"x11³/₄"

Amalfi

Cervinia

Cortina

Gallipoli**

Genova

Milano

Siena

Torino

Venezia



Spessori* Thicknesses*
Épaisseurs* Stärken*

mm 8,5

- Naturale Matt Naturelle Matt **R10 A**
- Levigata Polished Polie Poliert
- Roccia **R12 A+B+C**

* Spessore su superficie naturale.
Thickness on matt surface.
Épaisseur sur surface naturelle.
Stärke der Fliesen mit Mattoberfläche.

** Disponibile anche in 11,2 mm e 14,2 mm superficie naturale.
Available also in bigger thickness mm 11,2 and 14,2 matt surface.
Disponibile aussi en épaisseur majoré mm 11,2 et 14,2 surface naturelle.
Verfügbar in Überstärke mm 11,2 und 14,2 Mattoberfläche.



Uniforme
Uniform
Uniforme
Einheitlich

Caratteristiche tecniche e imballi a pagina
Technical features and packing on page
Caractéristiques techniques et emballages à la page
Technische Eigenschaften und Verpackungen auf Seite
444

PEZZI SPECIALI TRIMS ACCESSOIRES FORMSTÜCKE

Battiscopa* Bullnose*
Plinthe à bord arrondi* Stehsockel*
cm 9x30 - 3¹/₂"x11³/₄"



Gradino Step tread
Nez de marche Stufenplatte
cm 30x30 - 11³/₄"x11³/₄"

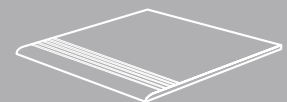

Tozzetto Insert
Caboçon Einleger
cm 9x9 - 3¹/₂"x 3¹/₂"



Listello Listel
Listel Zeierleiste
cm 9x30 - 3¹/₂"x11³/₄"



SUPERFICI SURFACES SURFACES OBERFLÄCHEN

granito 2
GRANITOGRES

levigata polished polie poliirt

naturale matt naturelle matt R10A

granito 3

GRANITOGRES

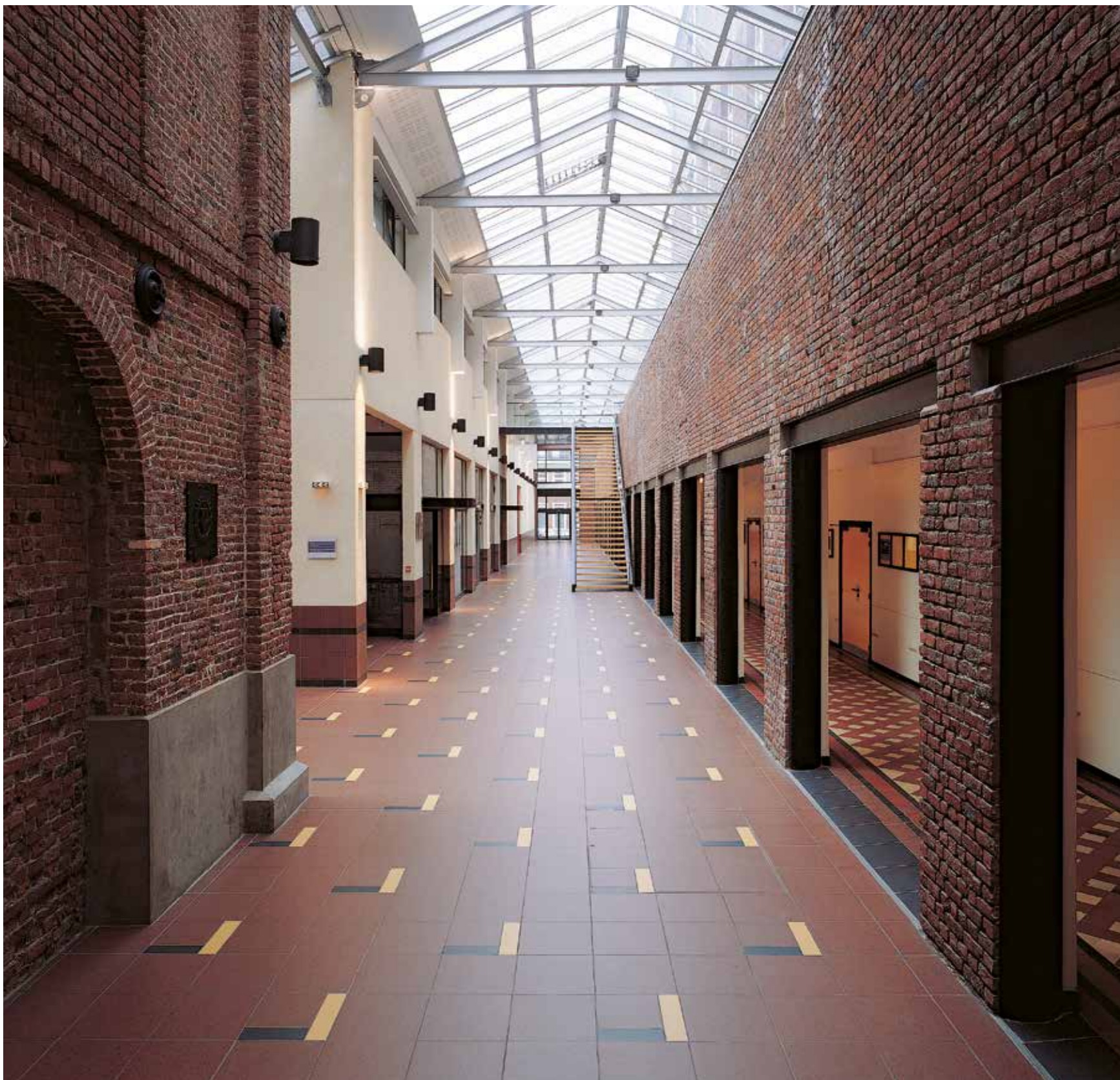

madrid cm 30x30 - 11³/₄"x11³/₄", unicolore listello giallo e nero

COLORI COLOURS COULEURS FARBEN

budapest



montreal

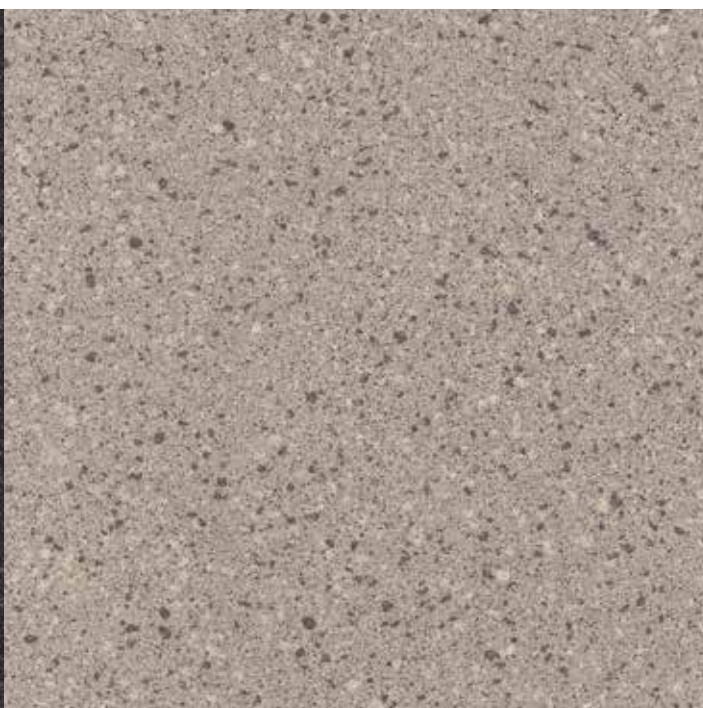

ankara



madrid

ajaccio

tokyo

granito 3

GRANITOGRES

shanghai



casablanca



helsinki



madrid

cm 12,5x25 - 4⁷/₈"x9⁷/₈"
roccia

FORMATI SIZES FORMATS FORMATE

Formati Sizes
Formats Formate



cm 30x30
11³/₄"x11³/₄"

Ajaccio



Ankara



Budapest



Casablanca



Helsinki



Madrid



Montreal



Shanghai**



Tokyo



Spessori* Thicknesses*
Épaisseurs* Stärken*

mm 8,5

- Naturale Matt Naturelle Matt **R10 A**
- Levigata Polished Polie Poliert

* Spessore su superficie naturale.
Thickness on matt surface.
Épaisseur sur surface naturelle.
Stärke der Fliesen mit Mattoberfläche.

** Disponibile anche in 14,2 mm superficie naturale.
Available also in bigger thickness mm 14,2 matt surface.
Disponibile aussi en épaisseur majoré mm 14,2 surface naturelle.
Verfügbar in Überstärke mm 14,2 Mattoberfläche.



Uniforme
Uniform
Uniforme
Einheitlich

Caratteristiche tecniche e imballi a pagina
Technical features and packing on page
Caractéristiques techniques et emballages à la page
Technische Eigenschaften und Verpackungen auf Seite
444

PEZZI SPECIALI TRIMS ACCESSOIRES FORMSTÜCKE

Battiscopa* Bullnose*
Plinthe à bord arrondi* Stehsockel*
cm 9x30 - 3¹/₂"x11³/₄"



Gradino Step tread
Nez de marche Stufenplatte
cm 30x30 - 11³/₄"x11³/₄"

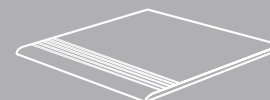

Tozzetto Insert
Caboçon Einleger
cm 9x9 - 3¹/₂"x 3¹/₂"



Listello Listel
Listel Zeierleiste
cm 9x30 - 3¹/₂"x11³/₄"



SUPERFICI SURFACES SURFACES OBERFLÄCHEN

granito 3
GRANITOGRES

levigata polished polie poliert

naturale matt naturelle matt R10A

granito 4

GRANITOGRES



fiji cm 60x60 - 23⁵/₈"x23⁵/₈" levigata polished

COLORI COLOURS COULEURS FARBEN

hawaii



madagascar



fiji

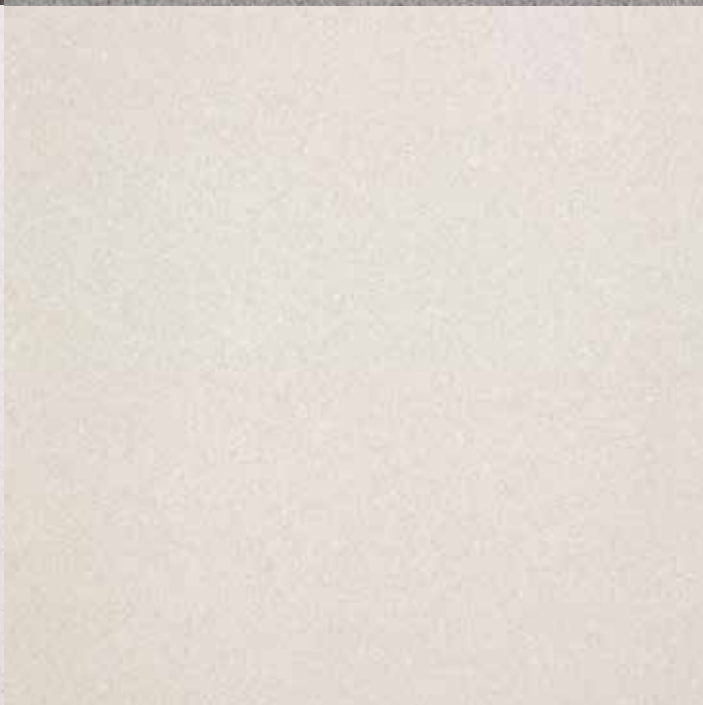
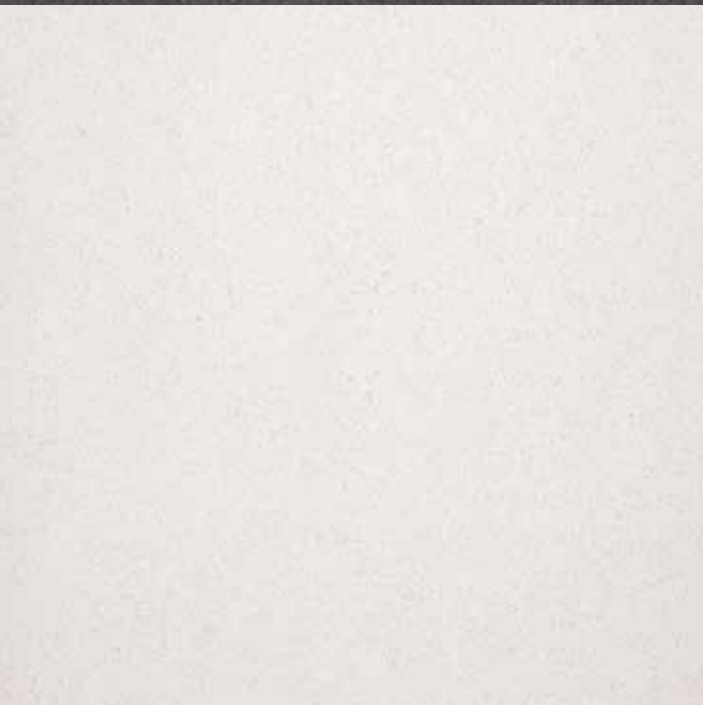

groenlandia

islanda

granito 4

GRANITOGRES



hawaii cm 60x60 - 23⁵/₈"x23⁵/₈" *bocciardata*

FORMATI SIZES FORMATS FORMATE

Formati Sizes Formate Formats		
	cm 30x60 11 ³ / ₄ "x23 ⁵ / ₈ "	cm 60x60 23 ⁵ / ₈ "x23 ⁵ / ₈ "
Superfici Surfaces Surfaces Oberflächen		
Spessori Thicknesses Epaisseurs Stärken	mm 10,5	mm 10,5
<ul style="list-style-type: none">  Naturale Matt Naturelle Matt R9  Levigata Polished Polie Poliert  Bocciardata R12 A+B+C 	 <p>Uniforme Uniform Uniforme Einheitlich</p>	<p>Caratteristiche tecniche e imballi a pagina Technical features and packing on page Caractéristiques techniques et emballages à la page Technische Eigenschaften und Verpackungen auf Seite 444</p>

PEZZI SPECIALI TRIMS ACCESSOIRES FORMSTÜCKE

Battiscopa* Bullnose*
Plinthe à bord arrondi* Stehsockel*
cm 9x60 - 3¹/₂"x23⁵/₈"



Gradino Step tread
Nez de marche Stufenplatte
cm 30x60 - 11³/₄"x23⁵/₈"

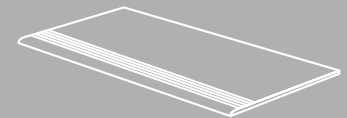

SUPERFICI **SURFACES** SURFACES OBERFLÄCHEN

granito 4
GRANITOGRES

levigata polished polie poliirt

naturale matt naturelle matt R9

bocciardata bocciardata bouchardée gehämmert R12 A+B+C

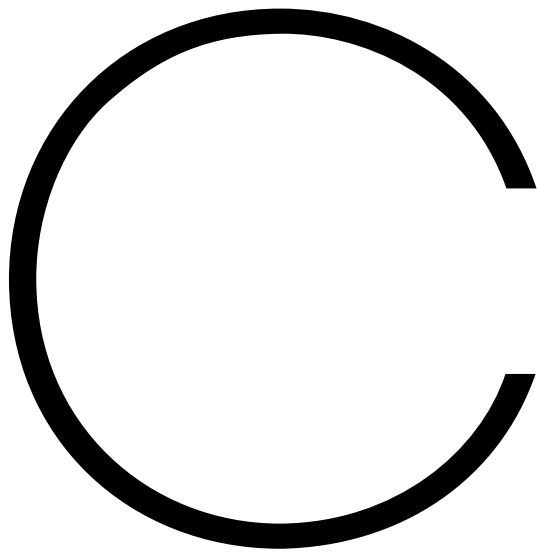
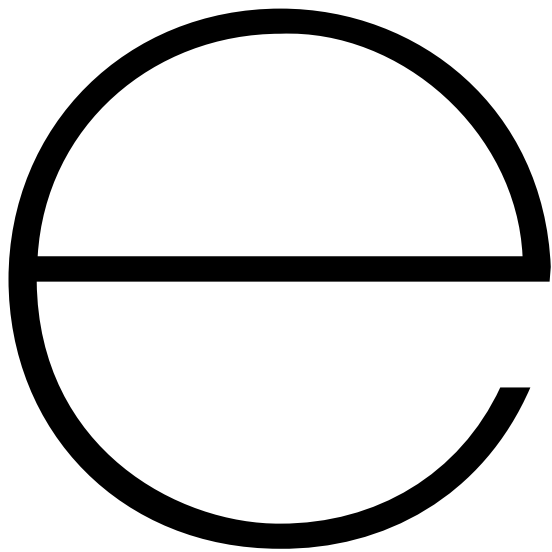

eco**colour** éco**couleur** öko**farbe**

colore

eco**colore**

- 324 **earth**
- 332 **architecture**
- 344 **unicolore**
- 352 **caleidoscopio**

COLORE

COLOUR

La luce riflessa di un corpo, che si diversifica in base alla lunghezza d'onda della radiazione o delle radiazioni elettromagnetiche di cui è costituita. Possono essere distinti: colori semplici, cioè costituiti da una sola radiazione, come i colori fondamentali o dell'iride (rosso, arancio, giallo, verde, azzurro, indaco, violetto); colori composti, costituiti da più radiazioni; colori complementari, dalla cui sovrapposizione si ottiene la luce bianca; colori soggettivi, prodotti dalla sensazione fisiologica delle radiazioni sulla retina dell'occhio mediante la quale percepiamo la loro diversità.

The reflected light of a body that changes, depending on the wave length of the electromagnetic radiation or radiations of which it is made. There are: simple colours, i.e., formed by a single radiation, such as the primary colours or those of the iris (red, orange, yellow, green, sky blue, indigo, violet); compound colours, formed by several radiations; complementary colours, from which a white light is obtained when they are overlapped; subjective colours, produced by the physiological sensation created by the radiations on the retina of the eye with which we perceive their diversity.

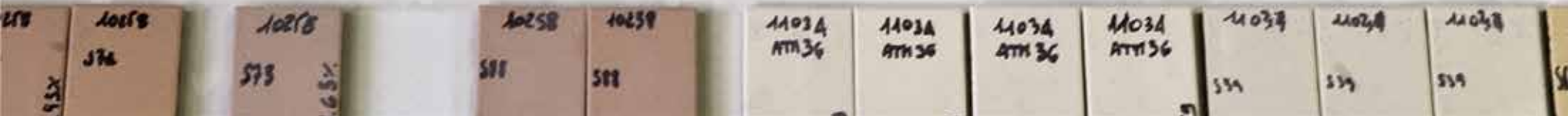
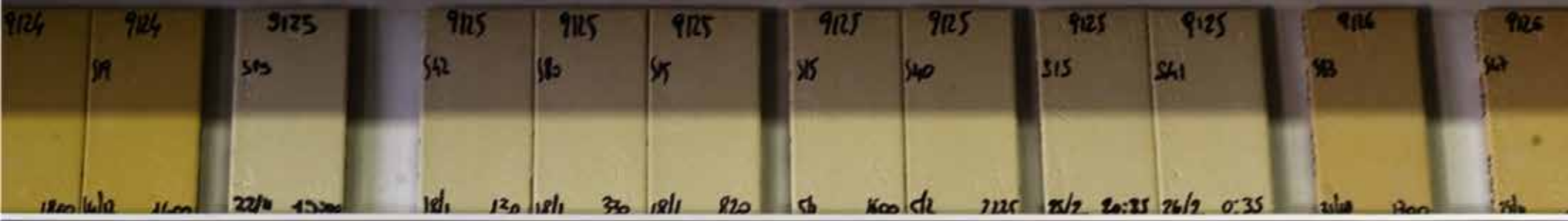

earth by pininfarina
GRANITOKER



grigio 4, grigio 1 cm 60x120 - 23⁵/₈"x47¹/₄", 30x120 - 11³/₄"x47¹/₄", 15x120 - 5⁷/₈"x47¹/₄"

COLORI COLOURS COULEURS FARBEN

blu



grigio 4

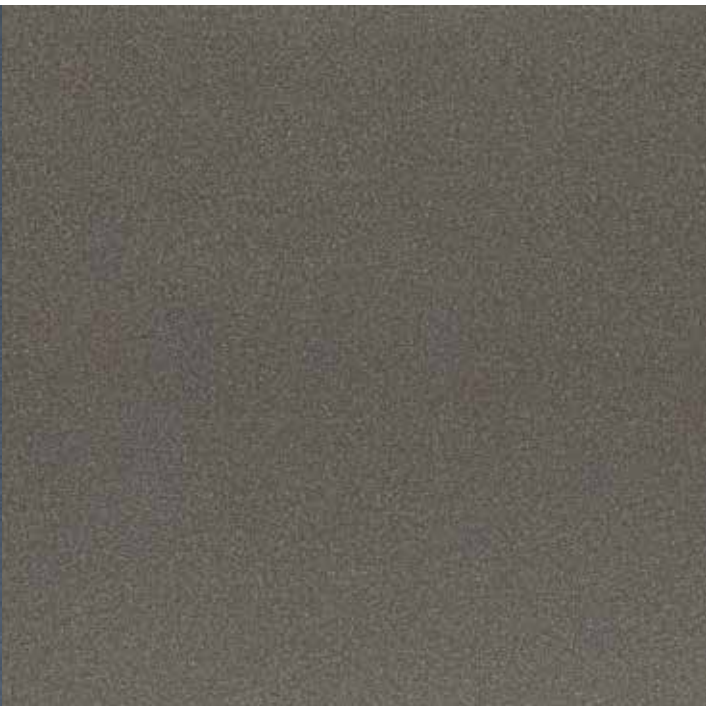

grigio 3

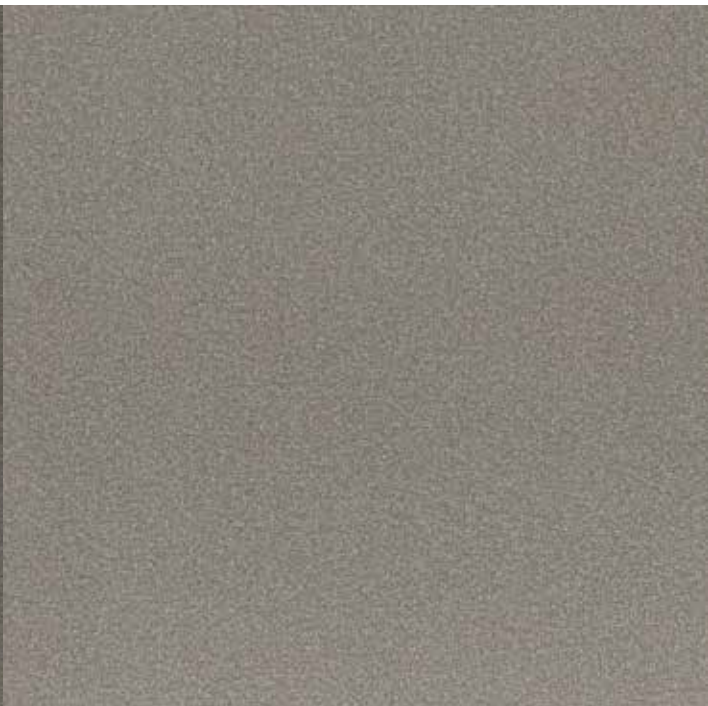

brunello



metalred



tortora 4



earth by pininfarina
GRANITOKER

grigio 2

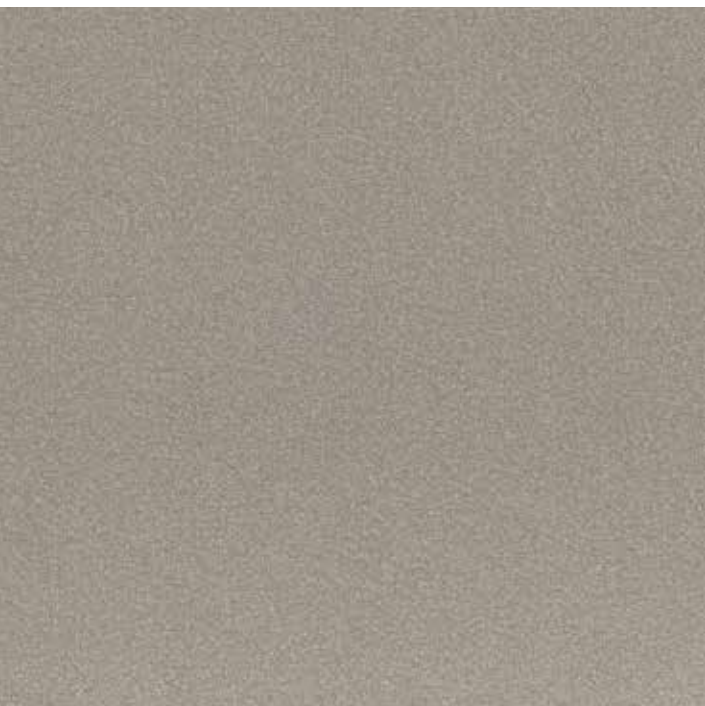

grigio 1

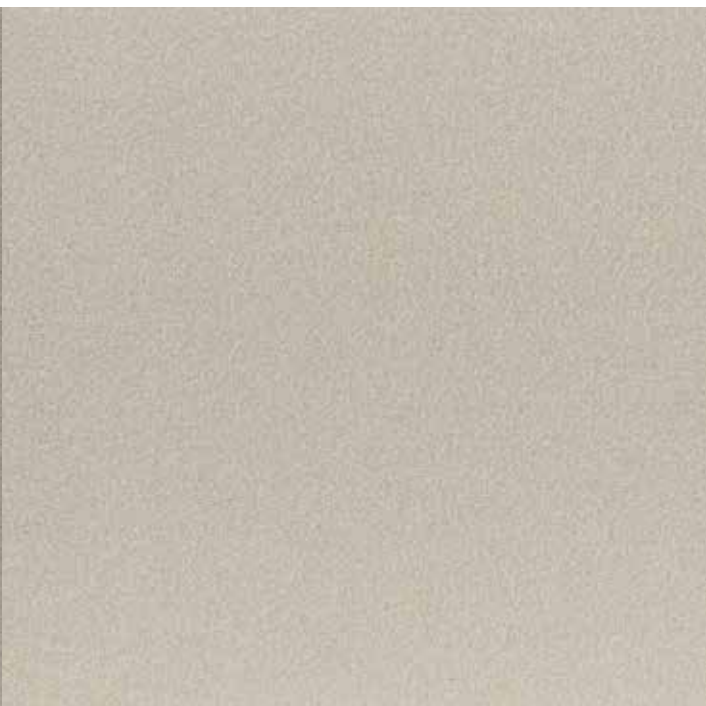

bianco

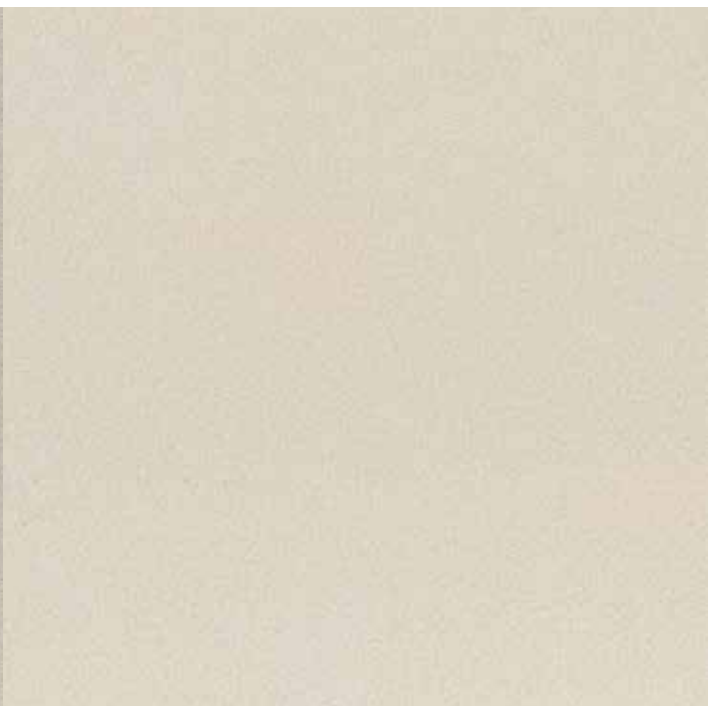

tortora 3

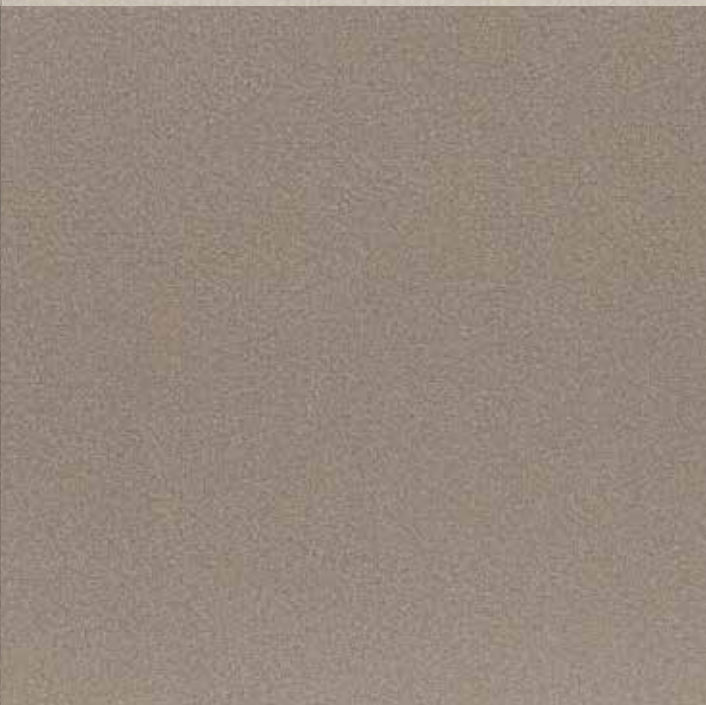

tortora 2



tortora 1

FORMATI SIZES FORMATS FORMATE

Formati Sizes Formats Formate	cm 30x60 11 ³ / ₄ "x23 ⁵ / ₈ "	cm 60x60 23 ⁵ / ₈ "x23 ⁵ / ₈ "	cm 15x120 5 ⁷ / ₈ "x47 ¹ / ₄ "	cm 30x120 11 ³ / ₄ "x47 ¹ / ₄ "	cm 60x120 23 ⁵ / ₈ "x47 ¹ / ₄ "
Superfici Surfaces Surfaces Oberflächen	●	●	●	●	●
Spessori Thicknesses Epaisseurs Stärken	mm 10,5	mm 10,5	mm 10,5	mm 10,5	mm 10,5

- Naturale Matt Naturelle Matt **R10**

Caratteristiche tecniche e imballi a pagina
 Technical features and packing on page
 Caractéristiques techniques et emballages à la page
 Technische Eigenschaften und Verpackungen auf Seite
450

PEZZI SPECIALI TRIMS ACCESSOIRES FORMSTÜCKE

Battiscopa Bullnose
Plinthe à bord arrondi Stehsockel
 cm 9x60 - 3¹/₂"x23⁵/₈"



Gradino Step tread
Nez de marche Stufenplatte
 cm 30x60 - 11³/₄"x23⁵/₈"



Gradone (assemblato)
 cm 60x33 - 23⁵/₈"x13"

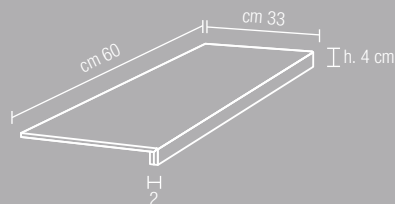

Angolare (assemblato)
 cm 60x33 - 23⁵/₈"x13"

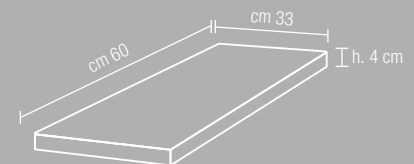

Terminale
Chrome/Silver
 cm 1x60 3/8"x23⁵/₈"



Spigolo terminale
Chrome/Silver
 cm 1x1 3/8"x3/8"



Spigolo listello
Chrome/Silver
 cm 1x3,6 3/8"x1 3/8"



LOGO

Piastrella con firma in acciaio.
Disponibile in tutti i formati
e colori della collezione.

Tile with steel signature.
Available in all the sizes
of the collection.

Dalle avec signature en acier.

Disponibile dans tous
les formats et dans toutes
les couleurs de la collection.

Fliese mit Signatur aus Stahl.
Verfügbar in allen Farben
und Formaten der Kollektion.

earth by pininfarina
GRANITOKER

pininfarina

pininfarina

DECORI DECORS DÉCORS DEKORE

line*

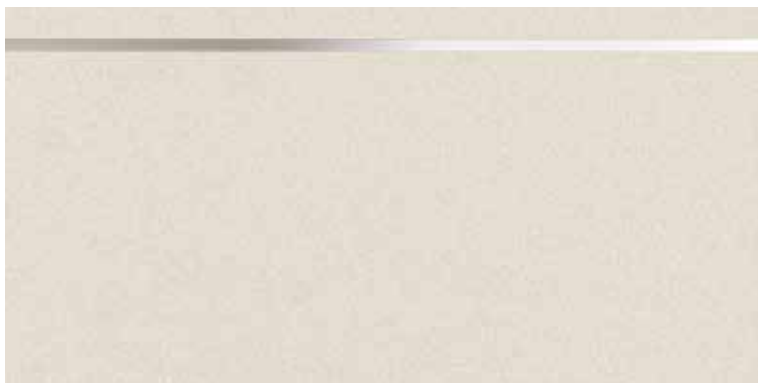

cm 30x60 - 11³/₄"x23⁵/₈"
 cm 60x120 - 23⁵/₈"x47¹/₄"
 cm 30x120 - 11³/₄"x47¹/₄"
 cm 15x120 - 5⁷/₈"x47¹/₄"

* Piastrella con inserto bacchetta argento lucido o cromata lucida.

Disponibile in tutti i colori della serie.

Tile with a polished silver or chrome-plated border strip. Available in all the colours of the series.

Dalle avec insert pour baguette argent brillant ou chromée brillante.

Disponibile dans toutes les couleurs de la série.

Fliese mit Zierleisteneinsatz aus poliertem Silber oder poliertem Chrom.

Verfügbar in allen Farben.



metalred, listello radica silver

cm 15x120 - 5⁷/₈"x47¹/₄", 30x120 - 11³/₄"x47¹/₄",
 60x120 - 23⁵/₈"x47¹/₄", 3,6x120 - 1³/₈"x47¹/₄"

VARNISH

listello mirror silver*



cm 3,6x60 - 1³/₈"x23⁵/₈"
 cm 3,6x120 - 1³/₈"x47¹/₄"

listello blu chrome**



cm 3,6x60 - 1³/₈"x23⁵/₈"
 cm 3,6x120 - 1³/₈"x47¹/₄"

listello red chrome**



cm 3,6x60 - 1³/₈"x23⁵/₈"
 cm 3,6x120 - 1³/₈"x47¹/₄"

* Cromato, con profili argento lucido.
 Chrome-plated, with polished silver profiles.
 Chromé, avec profilés de finition argent brillant.
 Chrom, mit Profilen aus poliertem Silber.

** In vernice micalizzata, con profili cromati lucidi.
 Made of 'mica' varnish, with polished chrome-plated profiles.
 En 'mica' peinture, avec profilés de finition chromés brillants.
 Aus 'mica' Anstrich mit Profilen aus poliertem Chrom.

Listello Logo con firma Pininfarina (un pezzo per scatola).

With Pininfarina signature (one piece per box).

Avec signature Pininfarina (une pièce pour boîte).

Mit Signatur Pininfarina (ein Stück pro Karton).



listello mirror silver, line, blu

cm 15x120 - 5⁷/₈"x47¹/₄", 30x120 - 11³/₄"x47¹/₄",
 60x120 - 23⁵/₈"x47¹/₄", 3,6x120 - 1³/₈"x47¹/₄"

DECORI DECORS DÉCORS DEKORE

earth by pininfarina
GRANITOKER

WOOD

listello radica silver*

cm 3,6x60 - 1³/₈"x23⁵/₈"
cm 3,6x120 - 1³/₈"x47¹/₄"

listello palissandro silver*

cm 3,6x60 - 1³/₈"x23⁵/₈"
cm 3,6x120 - 1³/₈"x47¹/₄"

listello daniela silver*

cm 3,6x60 - 1³/₈"x23⁵/₈"
cm 3,6x120 - 1³/₈"x47¹/₄"

* In legno naturale, con profili argento lucido.
Made of real wood with polished silver profiles.
En bois véritable, avec profilés de finition argent brillant.
Aus echtem Holz mit Profilen aus poliertem Silber.

Listello Logo con firma Pininfarina (un pezzo per scatola).
With Pininfarina signature (one piece per box).
Avec signature Pininfarina (une pièce pour boîte).
Mit Signatur Pininfarina (ein Stück pro Karton).

LEATHER

listello nubia chrome*

cm 3,6x60 - 1³/₈"x23⁵/₈"
cm 3,6x120 - 1³/₈"x47¹/₄"

listello castagna chrome*

cm 3,6x60 - 1³/₈"x23⁵/₈"
cm 3,6x120 - 1³/₈"x47¹/₄"

listello rojo chrome*

cm 3,6x60 - 1³/₈"x23⁵/₈"
cm 3,6x120 - 1³/₈"x47¹/₄"

* In vera pelle, con profili cromati lucidi.
Made of genuine leather with polished chrome-plated profiles.
En cuir naturel, avec profilés de finition chromés brillants.
Aus echtem Leder mit Profilen aus poliertem Chrom.

Listello Logo con firma Pininfarina (un pezzo per scatola).
With Pininfarina signature (one piece per box).
Avec signature Pininfarina (une pièce pour boîte).
Mit Signatur Pininfarina (ein Stück pro Karton).



listello daniela silver, line, tortora 2, tortora 4, bianco
cm 30x60 - 11³/₄"x 23⁵/₈", 60x60 - 23⁵/₈"x23⁵/₈",
3,6x60 - 1³/₈"x23⁵/₈"



listello castagna chrome, tortora 1, tortora 3
cm 15x120 - 57/8"x47¹/₄", 30x120 - 11³/₄"x47¹/₄",
60x120 - 23⁵/₈"x47¹/₄", 3,6x120 - 1³/₈"x47¹/₄"

architecture

GRANITOGRES



cool grey matt cm 90x90 - 35³/₈"x35³/₈"

COLORI COLOURS COULEURS FARBEN

black matt



black gloss



dark grey matt

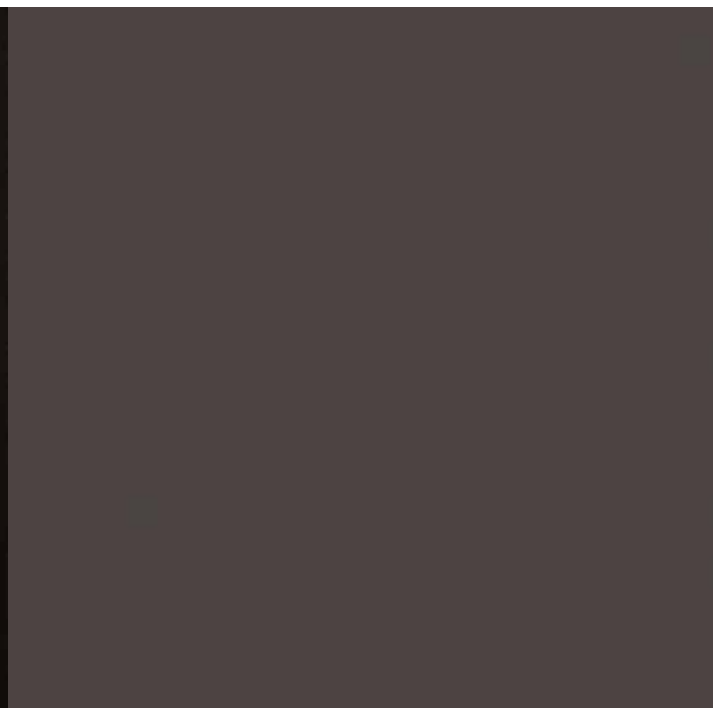

light grey matt



light grey gloss

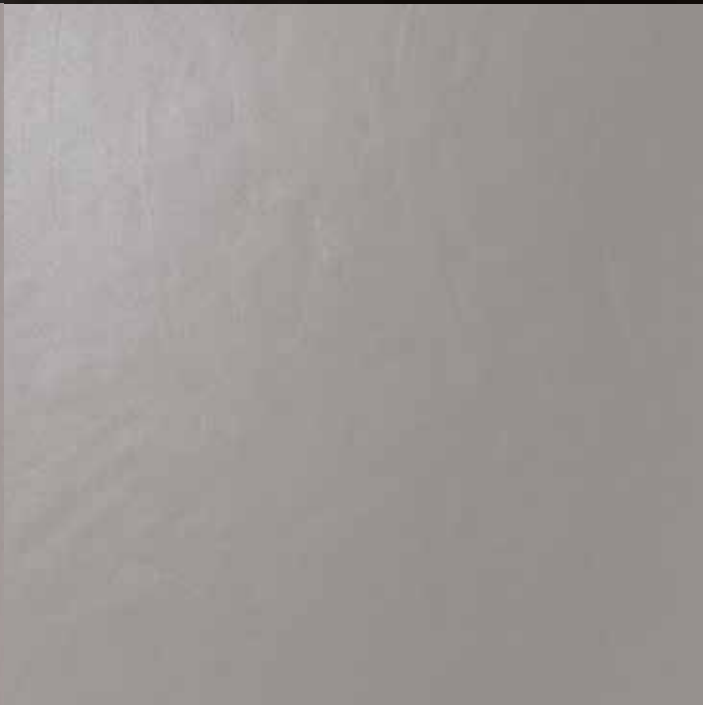

cool grey matt



architecture
GRANITOGRES

dark grey gloss



medium grey matt



medium grey gloss



cool grey gloss



warm grey matt



warm grey gloss



COLORI COLOURS COULEURS FARBEN

dark brown matt



dark brown gloss



light brown matt



dark ivory matt



dark ivory gloss



light ivory matt

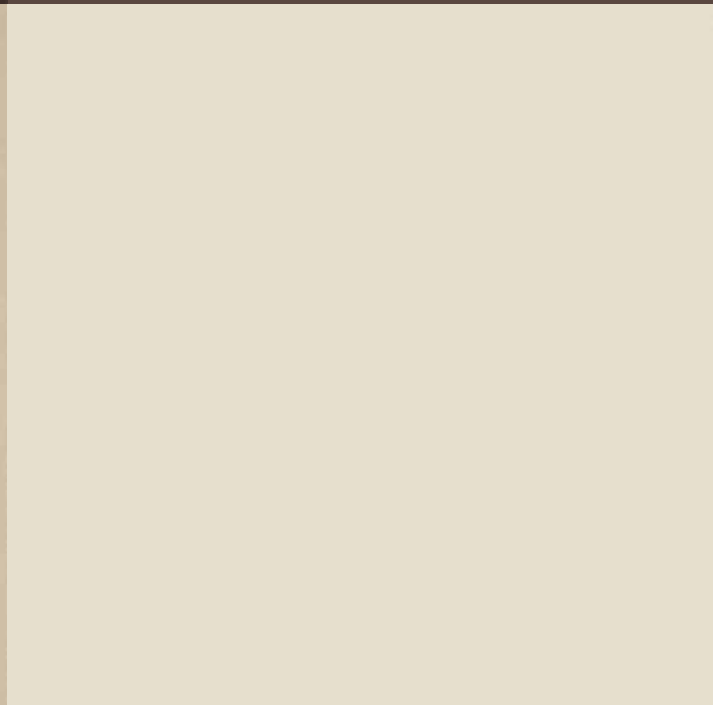

architecture
GRANITOGRES

light brown gloss



beige matt



beige gloss



light ivory gloss

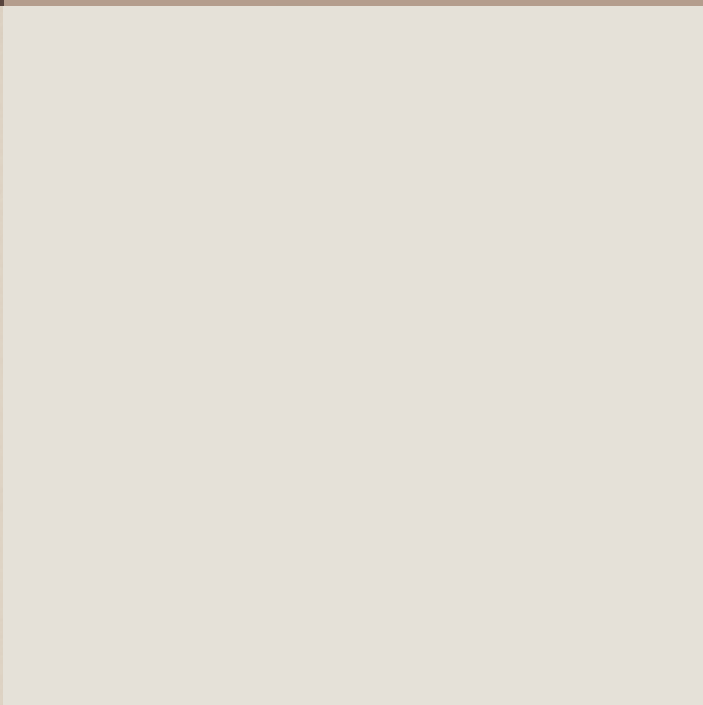

white matt

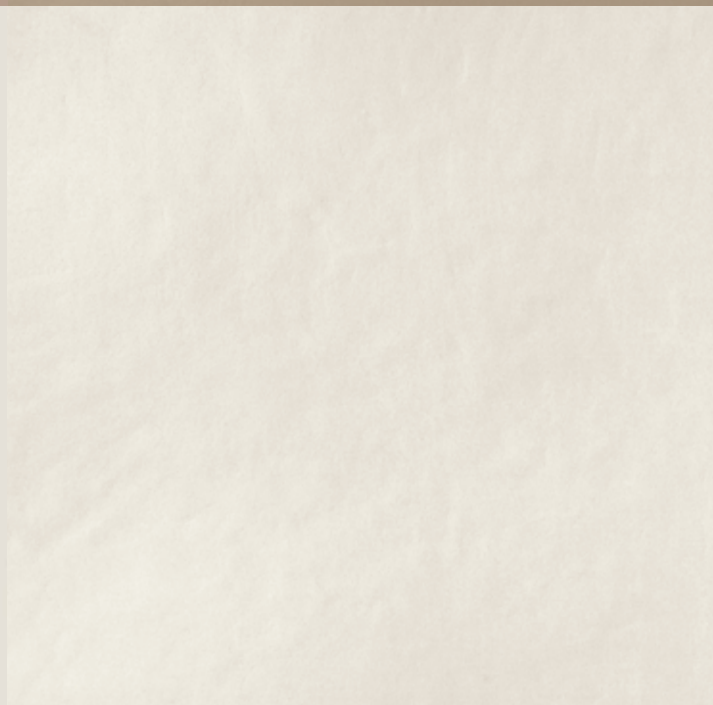

white gloss

COLORI COLOURS COULEURS FARBEN

purple matt



purple gloss



acid green matt



acid green gloss



**dark grey, light grey,
purple, white**

cm 60x60 - 23⁵/₈"x23⁵/₈"
15x60 - 5⁷/₈"x23⁵/₈"
15x15 - 5⁷/₈"x5⁷/₈"



white, black

cm 30x60 - 11³/₄"x23⁵/₈"

SUPERFICI SURFACES SURFACES OBERFLÄCHEN







architecture
GRANITOGRES

levigata polished polie poliert

naturale matt naturelle matt R9

gloss R9

FORMATI SIZES FORMATS FORMATE

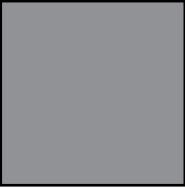
							
Formati Sizes Formats Formate	cm 30x30 11 ³ / ₄ "x11 ³ / ₄ "	cm 15x60 5 ⁷ / ₈ "x23 ⁵ / ₈ "	cm 30x60 11 ³ / ₄ "x23 ⁵ / ₈ "	cm 60x60 23 ⁵ / ₈ "x23 ⁵ / ₈ "	cm 15x90 5 ⁷ / ₈ "x35 ³ / ₈ "	cm 45x90 17 ³ / ₄ "x35 ³ / ₈ "	cm 90x90 35 ³ / ₈ "x35 ³ / ₈ "
Superfici Surfaces Surfaces Oberflächen	● ● ●	● ● ●	● ● ●	● ● ●	● ●	● ●	● ●
Spessori Thicknesses Epaisseurs Stärken	mm 9,4	mm 10,5 mm 9,4	mm 10,5 mm 9,4	mm 10,5	mm 10,5	mm 10,5	mm 10,5

- Naturale Matt Naturelle Matt **R9** (A richiesta On request Sur demand Auf Anfrage **R10**)
- Gloss **R9**
- Levigata Polished Polie Poliert

Nel caso di combinazioni di formati di spessori diversi, specificarlo espressamente nell'ordine.

Please specify in your order if you wish to purchase formats including more than one thickness.

Prière de spécifier dans votre commande si vous souhaitez acheter des formats avec différentes épaisseurs.

Bitte weisen Sie im Bestellungsformular ausdrücklich darauf hin, wenn Sie Formatkombinationen mit verschiedenen Stärken wünschen.



Uniforme
Uniform
Uniforme
Einheitlich

Caratteristiche tecniche e imballi a pagina

Technical features and packing on page

Caractéristiques techniques et emballages à la page

Technische Eigenschaften und Verpackungen auf Seite

444

PEZZI SPECIALI TRIMS ACCESSOIRES FORMSTÜCKE

Battiscopa Bullnose
Plinthe à bord arrondi **Stehsockel**
cm 9x60 - 3¹/₂"x23⁵/₈"
cm 9x90 - 3¹/₂"x35³/₈"



Gradino Step tread
Nez de marche **Stufenplatte**
cm 30x60 - 11³/₄"x23⁵/₈"



Gradone (assemblato)
cm 60x33 - 23⁵/₈"x13"

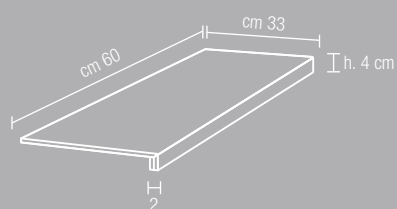

Angolare (assemblato)
cm 60x33 - 23⁵/₈"x13"

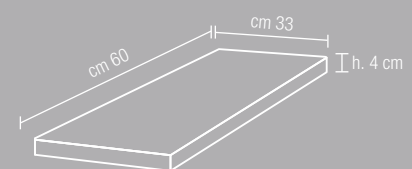

DECORI DECORS DÉCORS DEKORE

architecture
 GRANITOGRES

**mix listelli
 architecture A**

cm 30x30 - 11³/₄"x11³/₄"
 listello cm 1,4x30 - 1/2"x11³/₄"
su rete on net sur trame auf Netz
**beige, dark ivory,
 light ivory, white**
 naturale matt naturelle matt

**mix listelli
 architecture B**

cm 30x30 - 11³/₄"x11³/₄"
 listello cm 1,4x30 - 1/2"x11³/₄"
su rete on net sur trame auf Netz
**medium grey,
 dark grey black**
 naturale matt naturelle matt

**mix listelli
 architecture C**

cm 30x30 - 11³/₄"x11³/₄"
 listello cm 1,4x30 - 1/2"x11³/₄"
su rete on net sur trame auf Netz
**warm grey, cool grey,
 light grey, medium grey**
 naturale matt naturelle matt

**mix listelli
 architecture D**

cm 30x30 - 11³/₄"x11³/₄"
 listello cm 1,4x30 - 1/2"x11³/₄"
su rete on net sur trame auf Netz
**beige, dark brown,
 light brown**
 naturale matt naturelle matt

mix listelli*

cm 30x30 - 11³/₄"x11³/₄"
 listello cm 1,4x30 - 1/2"x11³/₄"
su rete on net sur trame auf Netz

* Disponibile in tutti i colori della serie.
 Available in all the colours of the series.
 Disponible dans tous les couleurs de la série.
 Verfügbar in allen Farben.
 Listelli in superficie gloss e naturale.
 Listellos in gloss and matt surface.
 Listelli en surface naturelle et gloss.
 Listelli Gloss und Natur Oberfläche.

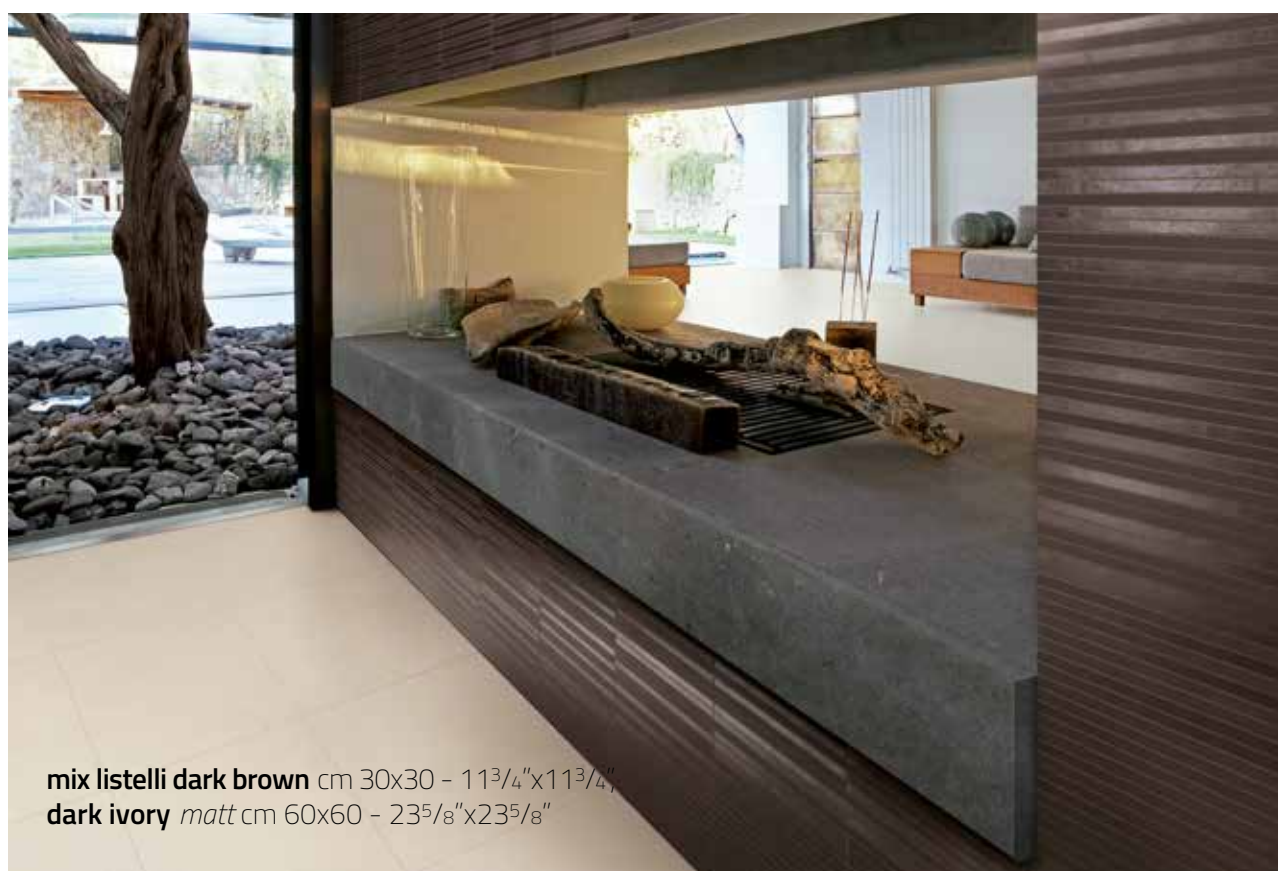

mix listelli dark brown cm 30x30 - 11³/₄"x11³/₄"
dark ivory *matt* cm 60x60 - 23⁵/₈"x23⁵/₈"

DECORI DECORS DÉCORS DEKORE

**mosaico
architecture A**



cm 30x30 - 11³/₄"x11³/₄"
tessera cm 1x1 - ³/₈"x³/₈"
su rete on net sur trame auf Netz

**beige, dark ivory,
light ivory, white**

**mosaico
architecture B**

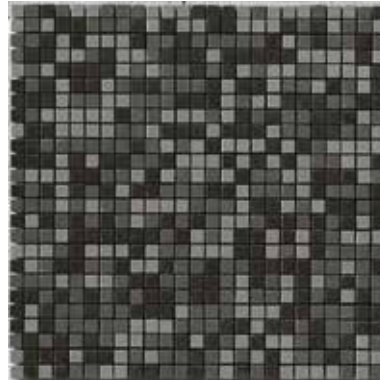

cm 30x30 - 11³/₄"x11³/₄"
tessera cm 1x1 - ³/₈"x³/₈"
su rete on net sur trame auf Netz

medium grey, dark grey, black

**mosaico
architecture C**

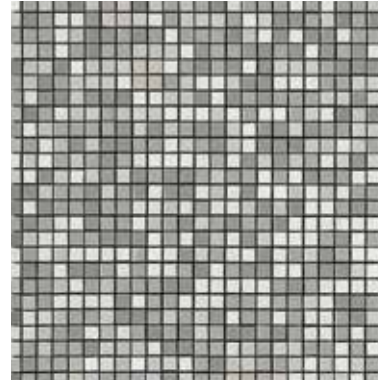

cm 30x30 - 11³/₄"x11³/₄"
tessera cm 1x1 - ³/₈"x³/₈"
su rete on net sur trame auf Netz

**warm grey, cool grey,
light grey, white**

**mosaico
architecture D**

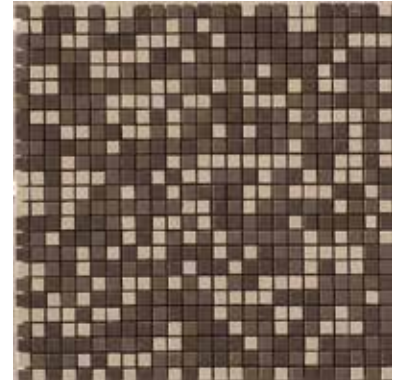

cm 30x30 - 11³/₄"x11³/₄"
tessera cm 1x1 - ³/₈"x³/₈"
su rete on net sur trame auf Netz

**beige, dark brown,
light brown**

**mosaico
architecture E**

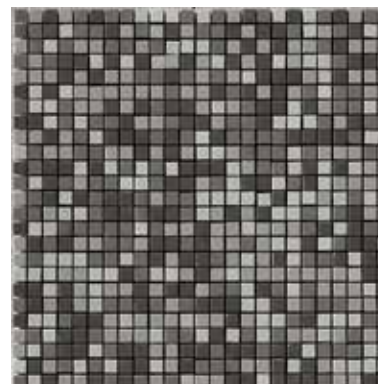

cm 30x30 - 11³/₄"x11³/₄"
tessera cm 1x1 - ³/₈"x³/₈"
su rete on net sur trame auf Netz

**dark grey, medium grey,
light grey, cool grey**



mosaico architecture C cm 30x30 - 11³/₄"x11³/₄",
cool grey *gloss* cm 60x60 - 23⁵/₈"x23⁵/₈"
white *matt* cm 15x90 - 5⁷/₈"x35³/₈"

architecture
GRANITOGRES

dark grey *gloss* cm 90x90 - 35³/₈"x35³/₈"

unicolore
GRANITOGRES



bianco assoluto *levigato polished* cm 60x60 - 23⁵/₈"x23⁵/₈", 60x120 - 23⁵/₈"x47¹/₄"

COLORI COLOURS COULEURS FARBEN

nero



grigio cenere



grigio perla



violet



blu forte

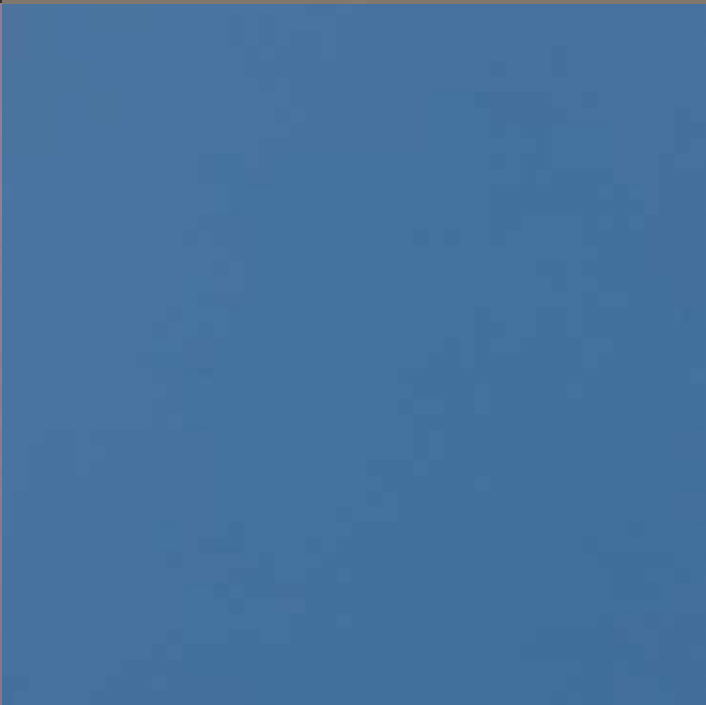

blu

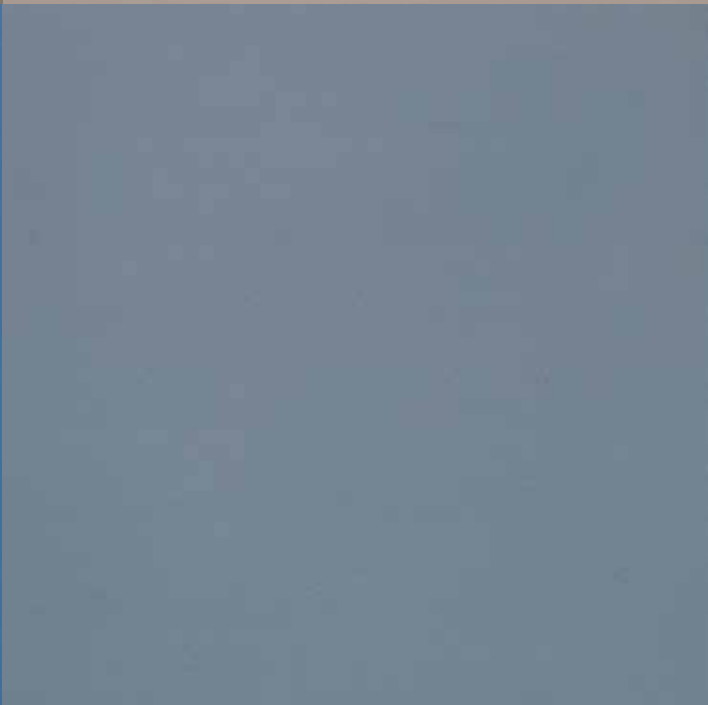

unicolore
GRANITOGRES

bianco avorio



bianco B



bianco assoluto

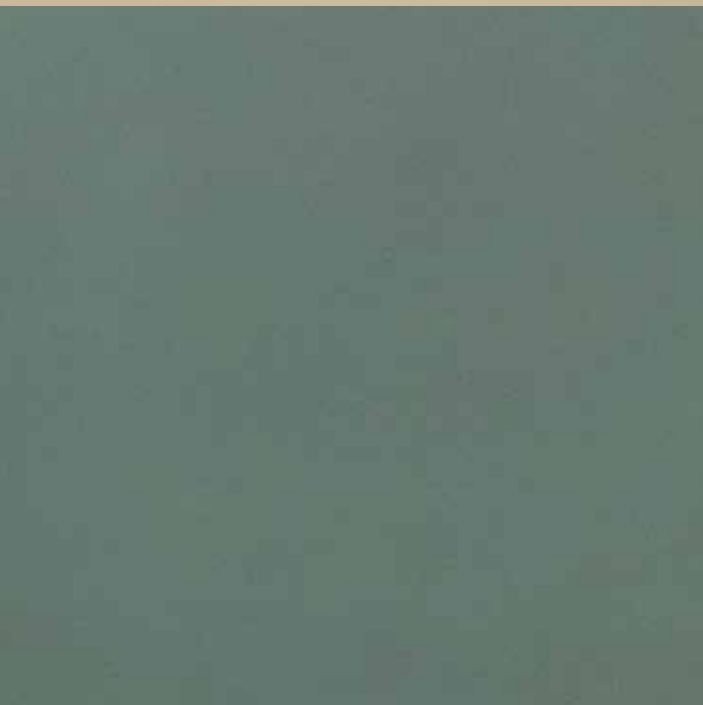
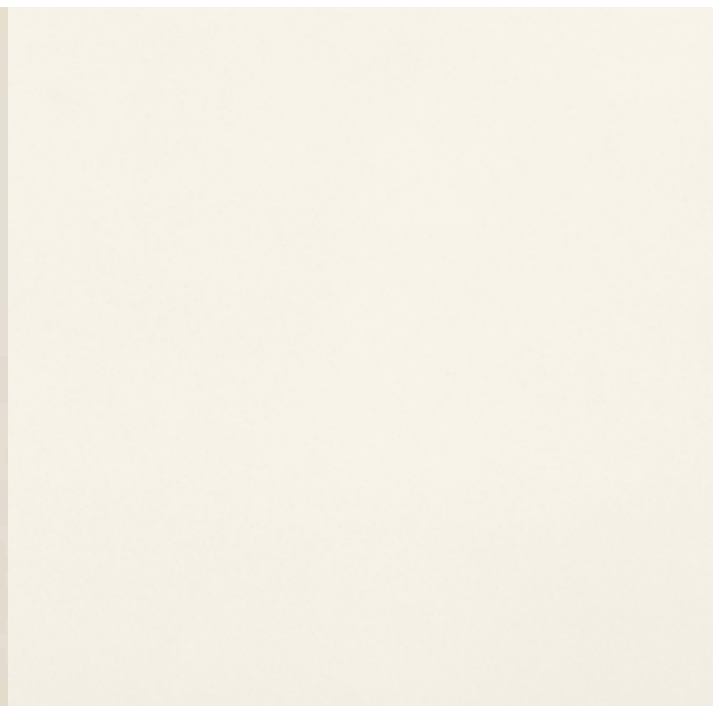

verde



grigio azzurro



acquamarina

COLORI COLOURS COULEURS FARBEN

rosso pompeii

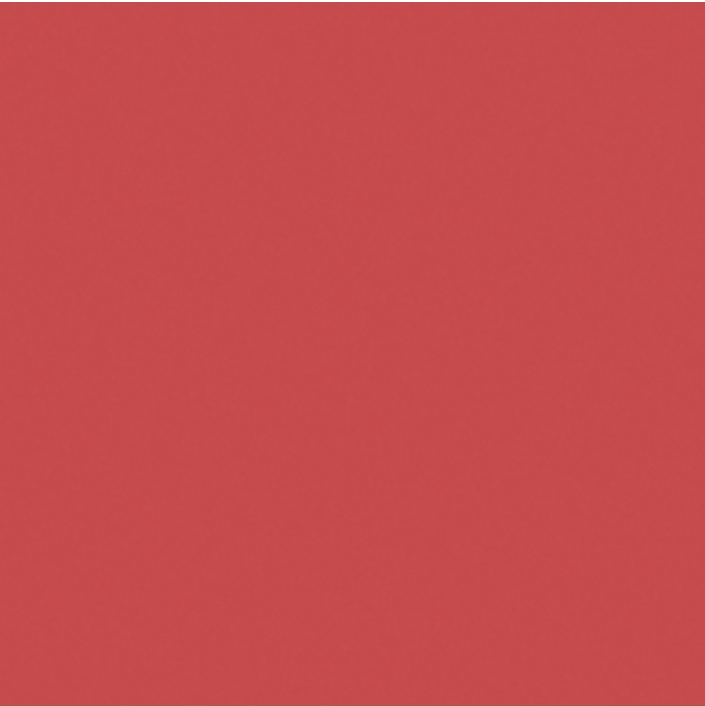

rosa antico



rosso mattone



giallo ocra

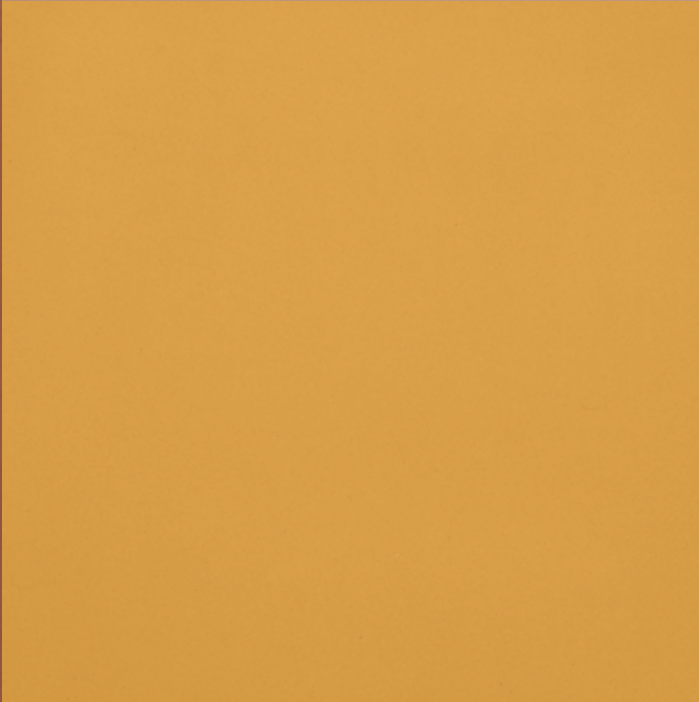









SUPERFICI **SURFACES** SURFACES OBERFLÄCHEN

unicolore
GRANITOGRES

levigata polished polie poliert

naturale matt naturelle matt R9A

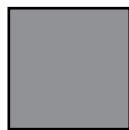
FORMATI SIZES FORMATS FORMATE

Formati Sizes Formats Formate	 cm 10x20** 4"x7 ^{7/8} "	 cm 20x20** 7 ^{7/8} "x7 ^{7/8} "	 cm 12,5x25** 4 ^{7/8} "x9 ^{7/8} "	 cm 30x30** 11 ^{3/4} "x11 ^{3/4} "	 cm 40x40** 15 ^{3/4} "x15 ^{3/4} "	 cm 30x60 11 ^{3/4} "x23 ^{5/8} "	 cm 60x60 23 ^{5/8} "x23 ^{5/8} "	 cm 60x120 23 ^{5/8} "x47 ^{1/4} "
Acquamarina		●		● ●	● ●			
Bianco Assoluto		●		● ●	● ●	● ●	● ●	● ●
Bianco Avorio	●	● ●	● ●	● ● ●	● ●			● ●
Bianco B	●	● ●	● ●	● ● ●	● ●	● ●	● ●	● ●
Blu		●		● ●	● ●			
Blu Forte		●		● ●	● ●			
Giallo Ocra		●		● ●	● ●			
Grigio Azzurro		●		● ●	● ●			
Grigio Cenere		● ●		● ● ●	● ●			
Grigio Perla		●		● ●	● ●			
Nero		●		● ●	● ●			
Rosa Antico		●		● ●	● ●			
Rosso Mattone		●		● ●	● ●			
Rosso Pompei		●		● ●	● ●			
Verde		●		● ●	● ●			
Violet		●		● ●	● ●			
Spessori* Thicknesses* Épaisseurs* Stärken*	mm 8	mm 8	mm 8	mm 8	mm 9	mm 10,5 mm 9,4***	mm 10,5	mm 10,5

- Naturale Matt Naturelle Matt **R9 A**
- Levigata Polished Polie Poliert
- Technic **R10**



Uniforme
Uniform
Uniforme
Einheitlich

Caratteristiche tecniche e imballi a pagina
Technical features and packing on page
Caractéristiques techniques et emballages à la page
Technische Eigenschaften und Verpackungen auf Seite
444

* Spessore su superficie naturale.
Thickness on matt surface.
Épaisseur sur surface naturelle.
Stärke der Fliesen mit Mattoberfläche.

** Non rettificato unico calibro.
Unrectified, monocalibre.
Non rectifié dans un calibre unique.
Nicht kalibriert Einziges Kaliber.

*** Solo Bianco Assoluto.
Only Bianco Assoluto.
Seulement Bianco Assoluto.
Nur Bianco Assoluto.

Per superfici speciali antiscivolo e spessori maggiorati vedere catalogo Technic.
For increased thicknesses and special no-slip surfaces see the Technic catalogue.
Pour des surfaces antidérapantes et les épaisseurs majorés, voir catalogue Technic.
Für sonderrutschhemmende Oberflächen und Stärken siehe Katalogue Technic.

PEZZI SPECIALI TRIMS ACCESSOIRES FORMSTÜCKE

Battiscopa Bullnose
Plinthe à bord arrondi Stehsockel
 cm 9x30 - 3½"x11¾"
 cm 9x40 - 3½"x15¾"
 cm 10x20 - 4"x7⅞"



Gradino Step tread
Nez de marche Stufenplatte
 cm 30x30 - 11¾"x11¾"

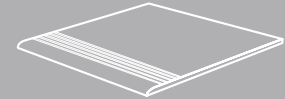

Tozzetto Insert
Cabochon Einleger
 cm 9x9 - 3½"x 3½"



* **Zoccolo a raccordo a taglio retto**
Cove base - straight top
Plinthe à gorge avec bord vif
Hohlkehlsocbel (scharfkantig)
 cm 10x20 - 4"x7⅞"

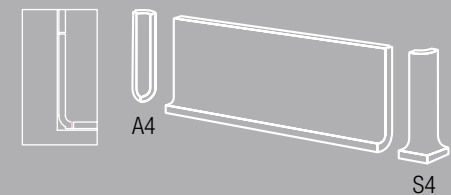

Listello Listel
Listel Zeierleiste
 cm 9x30 - 3½"x11¾"
 cm 9x40 - 3½"x15¾"



* **Zoccolo ad appoggio smussato**
Sit-on skirting - bevelled top
Plinthe à talon avec
bord arrondi
Aufsetzsockel mit
abgerundeter Kante
 cm 10x20 - 4"x7⅞"

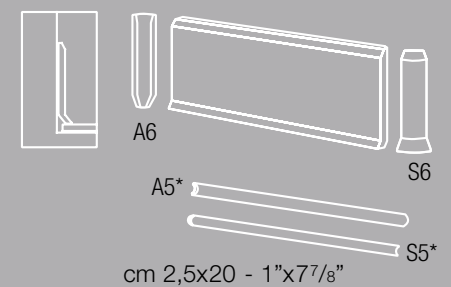

***Sguscetta** ***Cove**
 ***Gorge** ***Rinnleiste**
 cm 4x20 - 1⅝"x7⅞"



* Produzione corrente solo nei colori:
 Currently produced only in the following colours:
 Productions courantes seulement dans les couleurs:
 Aktuelle Produktion nur in den Farben:
Bianco Avorio, Bianco B

Altri colori sono prodotti solo su richiesta.
Other colours are produced on demand.
Autres teintes disponibles sur demand.
Andere Farben nur auf Anfrag.



grigio cenere cm 30x30 - 11¾"x11¾"

caleidoscopio

ECOGRES



pistacchio, caffè cm 20x20 - 7⁷/₈"x7⁷/₈"

COLORI COLOURS COULEURS FARBEN

liquirizia

caffè

oceano

smeraldo

oliva

pistacchio

cobalto

marina

anice

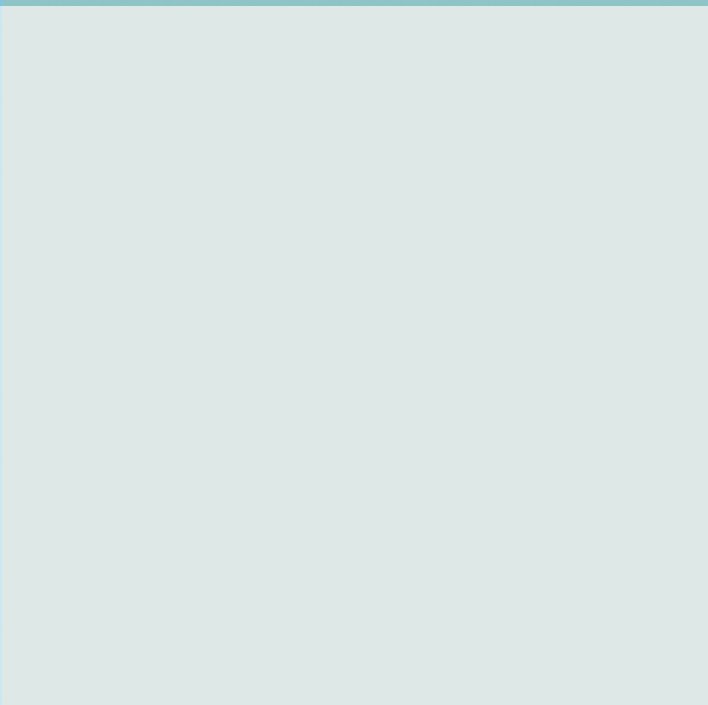
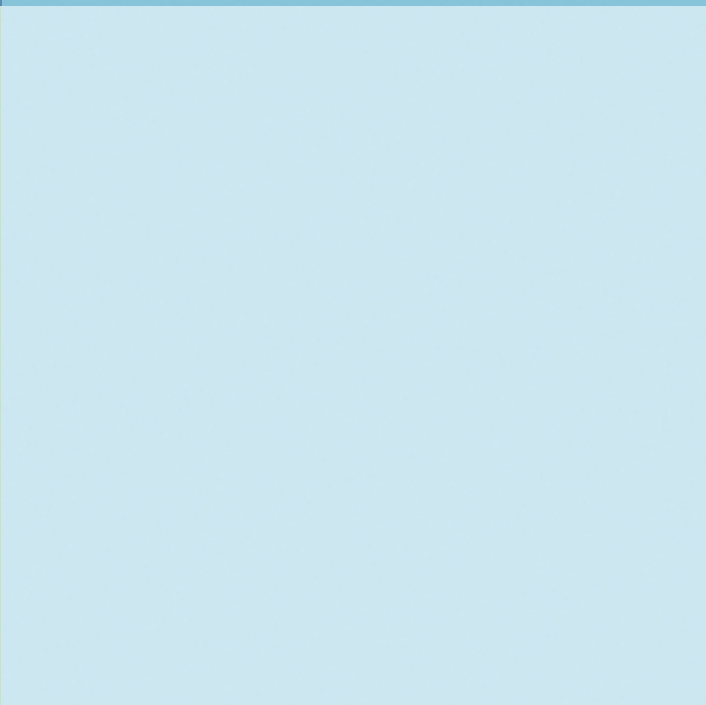
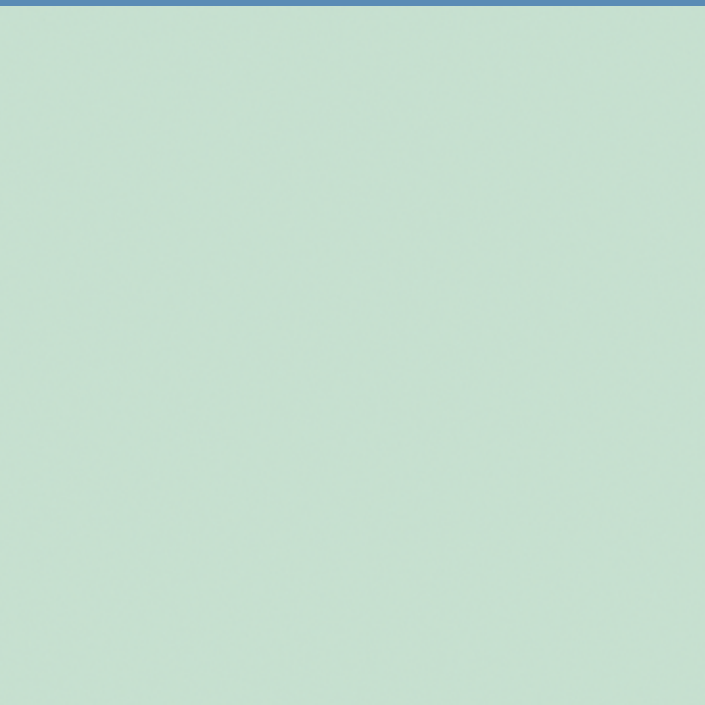
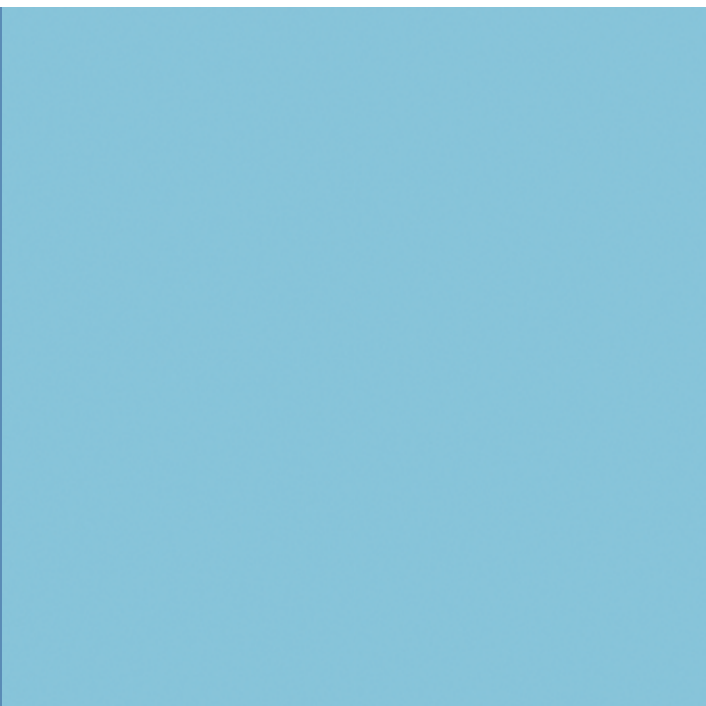

menta

cielo

pack

COLORI COLOURS COULEURS FARBEN

rosso selenio



corallo



ocra



antracite



granita

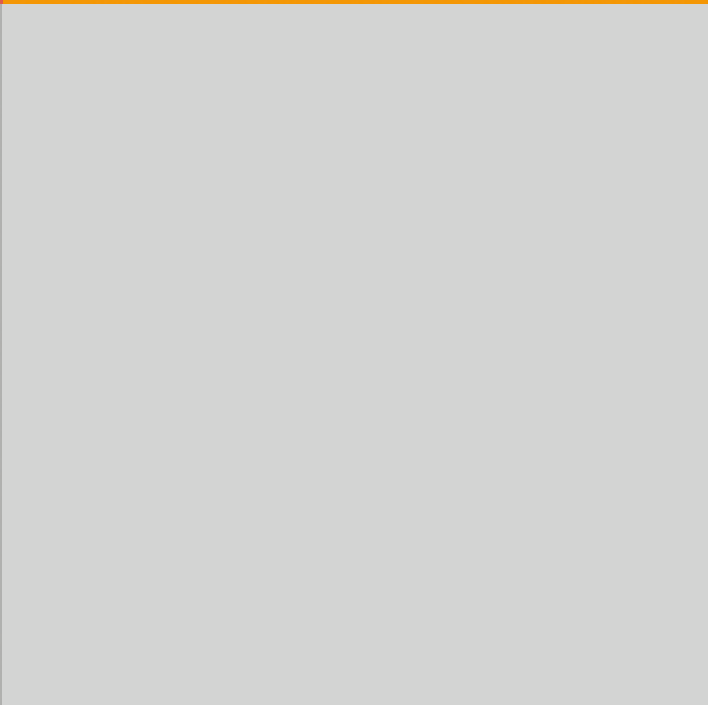

ghiaccio

caramel



fragola



panna

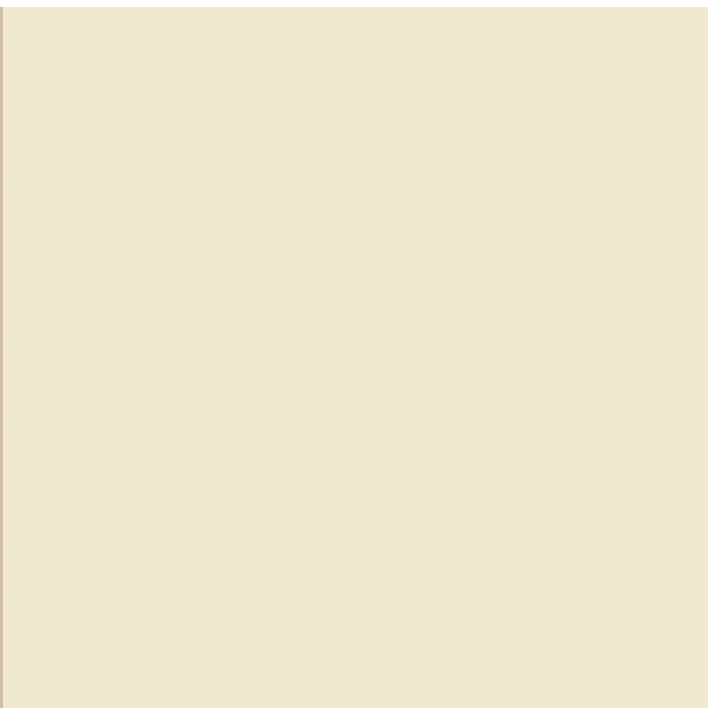

betulla

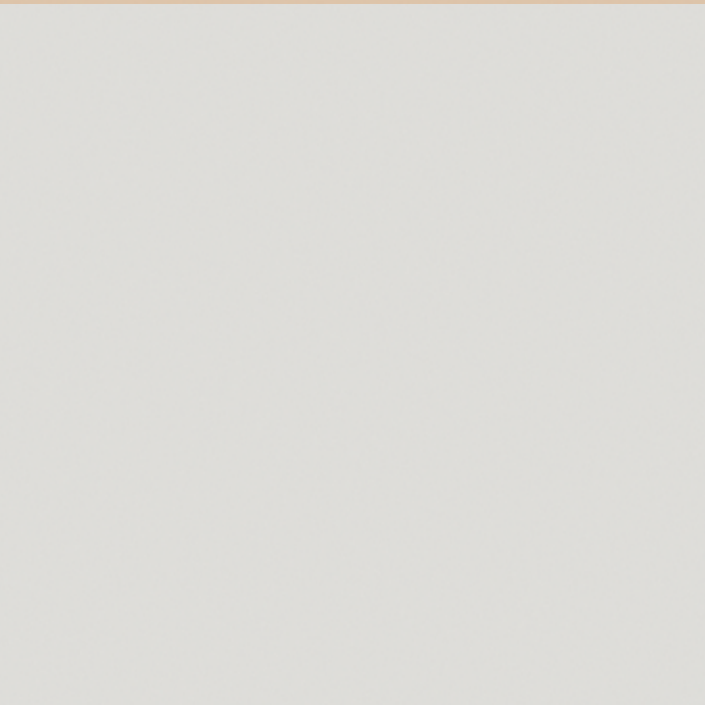

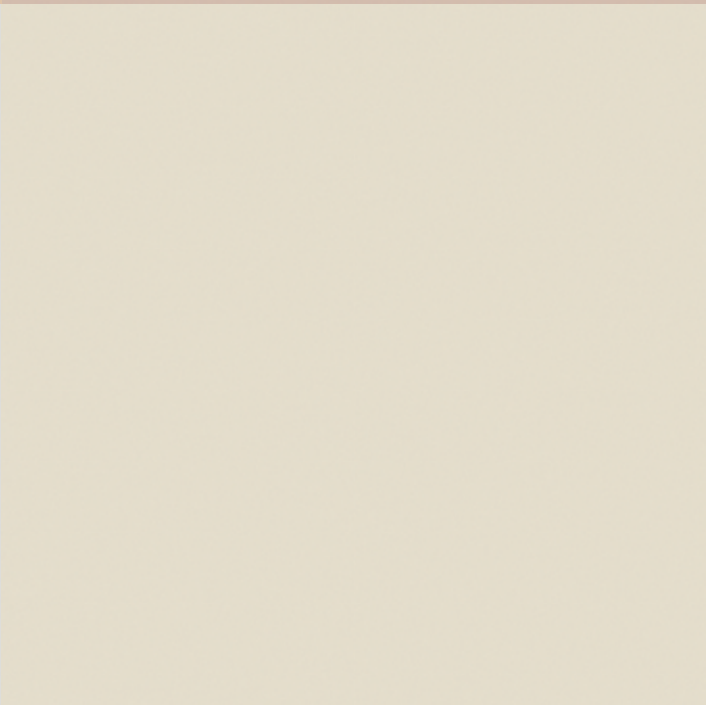

avorio

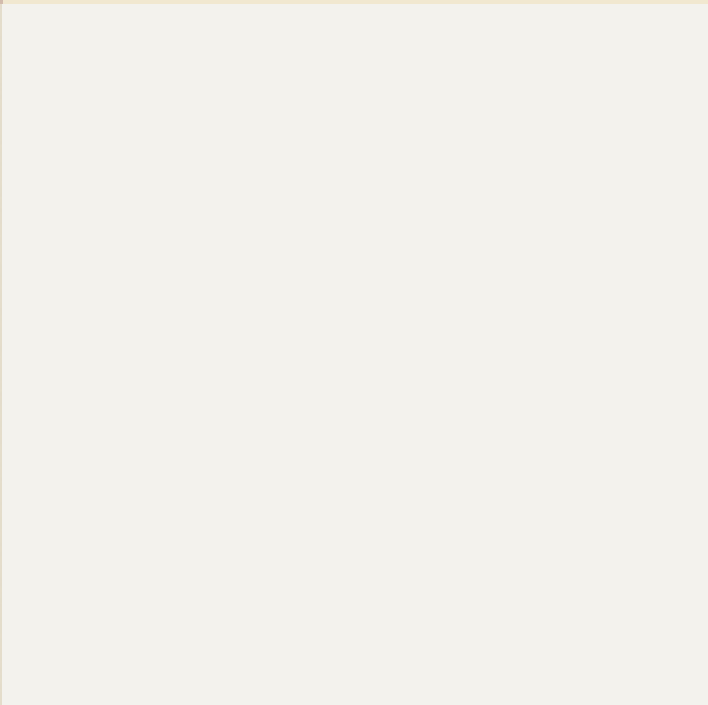

cocco



FORMATI SIZES FORMATS FORMATE

Formati Sizes Formats Formate	 cm 10x20 4"x7 ⁷ / ₈ "	 cm 20x20 7 ⁷ / ₈ "x7 ⁷ / ₈ "	 cm 33x33 13"x13"
Anice G3*		● ●	
Antracite G3*		●	
Avorio G3*		●	
Betulla G3*	●	● ●	●
Caffè G2*		●	
Caramel G3*		●	
Cielo G3*		●	
Cobalto G3*		●	
Cocco G3*	●	●	●
Corallo G3*		●	
Fragola G3*		●	
Ghiaccio G3*		●	
Granita G3*		● ●	
Liquirizia G2*		●	
Marina G3*		●	
Menta G3*		●	
Oceano G2*		●	
Ocra G3*		●	
Oliva G2*		●	
Pack G3*		●	
Panna G3*		●	
Pistacchio G2*		●	
Rosso selenio G2*		●	
Smeraldo G2*		●	
Spessor Thicknesses Epaisseurs Stärken	mm 7,3	mm 7,3	mm 8,2

- Naturale Matt Naturelle Matt
- Grip **R10**

* Vedi pagina See page Voir page Siehe Seite
455



Uniforme
Uniform
Uniforme
Einheitlich

Caratteristiche tecniche e imballi a pagina
Technical features and packing on page
Caractéristiques techniques et emballages à la page
Technische Eigenschaften und Verpackungen auf Seite
454

PEZZI SPECIALI TRIMS ACCESSOIRES FORMSTÜCKE

Battiscopa Bullnose**
Plinthe à bord arrondi Stehsocket*
cm 8x33 - 3¹/₂"x11³/₄"



Conchiglia**



Sguscetta Cove**
Gorge Rinneleiste*
cm 2,5x20 - 1"x7⁷/₈"



Piè d'oca**



DECORI DECORS DÉCORS DEKORE

matita***



cm 2x20
3/4"x7⁷/₈"

london***



cm 3x20
1¹/₈"x7⁷/₈"

spigolo***



***Disponibile nei colori: Available in the colours:

Disponibile dans les couleurs: Verfügbar in den folgenden Farben:

anice, caramel, cobalto, fragola, granita, marina, menta, pack, smeraldo

** Produzione corrente solo nei colori: Currently produced only in the following colours:
Productions courantes seulement dans les couleurs: Aktuelle Produktion nur in den Farben:
Betulla, Cocco

SUPERFICI **SURFACES** SURFACES OBERFLÄCHEN

caleidoscopio
ECOGRES

naturale matt naturelle matt

grip R10

e

C



eco**concrete** éco**ciment** öko**zement**

cemento

ecocemento

- 364 **beton**
- 372 **cemento**
- 380 **resina**
- 386 **spazio**
- 392 **econcrete**
- 396 **loft**
- 402 **feel**
- 406 **living**
- 410 **venezia**
- 414 **old season**
- 418 **cotto cerato**

511

CEMENTO

Composto di silicati e alluminati di calcio ottenuto attraverso la cottura a elevata temperatura di calcare e argilla o di marna. La materia prima risultante viene macinata e addizionata con altri componenti per specializzarne le prestazioni in funzione dell'impiego. Miscelato con acqua, si idrata e solidifica progressivamente.

CONCRETE

Composed of silicates and calcium aluminates, made by cooking limestone and clay or marl at high temperatures. The resulting material is crushed and mixed with other ingredients to make it perform according to its intended use. Mixed with water, it progressively gets hydrated and sets.

84



beton
GRANITOKER



ivory cm 75,5x151 - 29³/₄"x59¹/₂"

COLORI COLOURS COULEURS FARBEN

dark



pearl

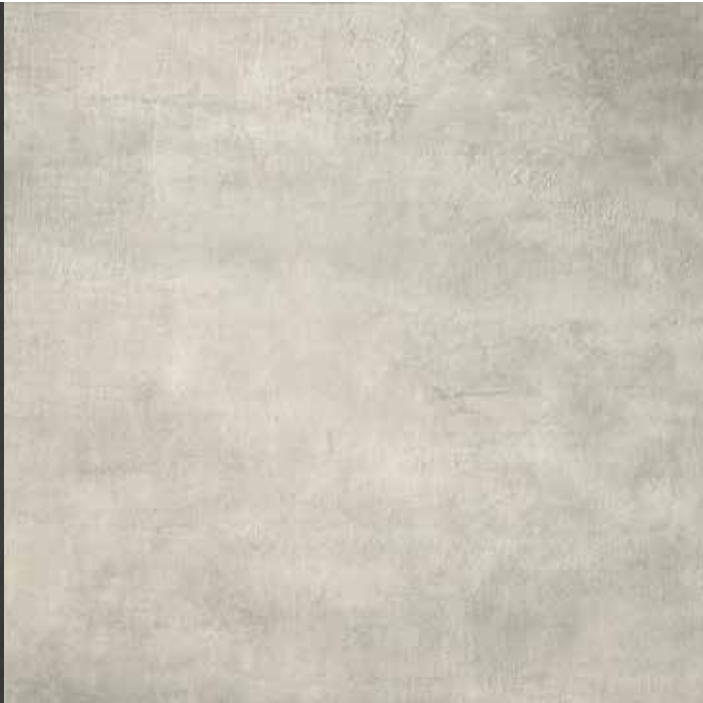

mud



sand



ivory

beton

GRANITOKER

dark cm 75,5x75,5 - 29³/₄"x29³/₄"

BETON

CEMENTO

RESINA

SPAZIO

ECONCRETE

LOFT

FEEL





LIVING

VENEZIA

OLD SEASON

COTTO CERATO

FORMATI SIZES FORMATS FORMATE

Formati Sizes Formats Formate			
	cm 37,5x75,5 14 ³ / ₄ "x29 ³ / ₄ "	cm 75,5x75,5 29 ³ / ₄ "x29 ³ / ₄ "	cm 75,5x151 29 ³ / ₄ "x59 ¹ / ₂ "
Superfici Surfaces Surfaces Oberflächen	●	●	●
Spessori Thicknesses Epaisseurs Stärken	mm 10 mm 9	mm 10	mm 10
● Naturale Matt Naturelle Matt R10 Rettificate in un unico calibro. Single caliber, rectified. Version Rectifiés en un unique calibre. Kalibriert einziges Kaliber.		 Media Medium Moyenne Mittel	Caratteristiche tecniche e imballi a pagina Technical features and packing on page Caractéristiques techniques et emballages à la page Technische Eigenschaften und Verpackungen auf Seite 450

PEZZI SPECIALI TRIMS ACCESSOIRES FORMSTÜCKE

Battiscopa Bullnose
Plinthe à bord arrondi Stehsockel
cm 9x75,5 - 3¹/₂"x29³/₄"



Gradino Step tread
Nez de marche Stufenplatte
cm 37,5x75,5 - 14³/₄"x29³/₄"



Gradone (assemblato)
cm 75,5x33 - 29³/₄"x13"

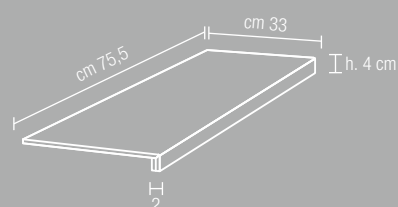

Angolare (assemblato)
cm 60x33 - 23⁵/₈"x13"

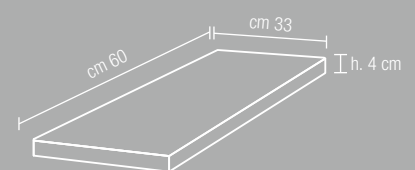

beton

GRANITOKER



pearl cm 75,5x151 - 29³/₄"x59¹/₂"

DECORI DECORS DÉCORS DEKORE

inserto beton A

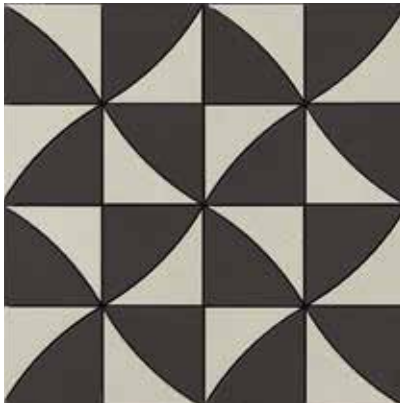

cm 37,5x37,5 - 14³/₄"x14³/₄"
1 pearl+dark
2 mud+ivory

inserto beton B



cm 37,5x37,5 - 14³/₄"x14³/₄"
1 pearl+dark
2 mud+ivory

inserto beton C

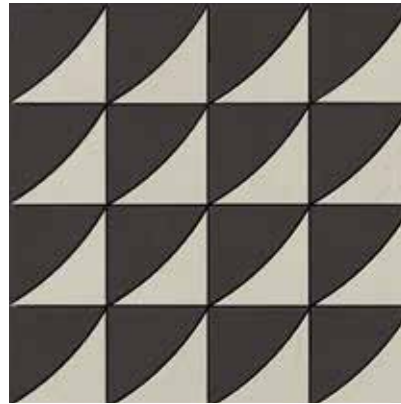

cm 37,5x37,5 - 14³/₄"x14³/₄"
1 pearl+dark
2 mud+ivory

inserto beton D

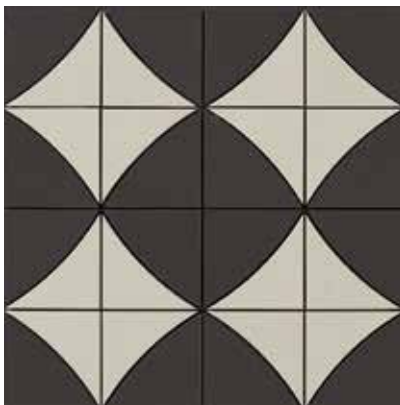

cm 37,5x37,5 - 14³/₄"x14³/₄"
1 pearl+dark
2 mud+ivory

inserto beton E



cm 37,5x37,5 - 14³/₄"x14³/₄"
1 pearl+dark
2 mud+ivory



DECORI DECORS DÉCORS DEKORE

beton
GRANITOKER

quadrotta beton



cm 25,1x25,1 - 9⁷/₈"x9⁷/₈"
pearl



cm 25,1x25,1 - 9⁷/₈"x9⁷/₈"
pearl

mosaico 6x6*



cm 30x30 - 11³/₄"x11³/₄"
tessera 6x6 - 2³/₈" x 2³/₈"
su rete on net sur trame auf Netz

mosaico tessuto

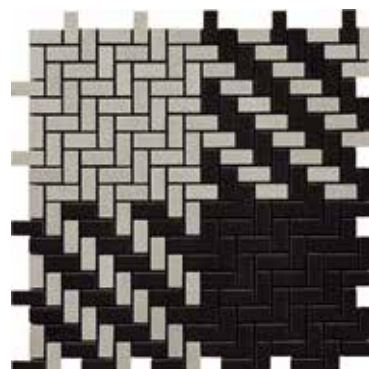

cm 25,1x25,1 - 9⁷/₈"x9⁷/₈"
1 pearl+dark
2 mud+ivory

affresco*



cm 75,5x151 - 29³/₄"x59¹/₂"
decorato a mano hand decorated décoré à la main Handbemalt

* Disponibile in tutti i colori della serie.
Available in all the colours of the series.
Disponibile dans tous les couleurs de la série.
Verfügbar in allen Farben.

cemento rasato antracite

cemento
GRANITOKER



rasato antracite cm 60x120 - 23⁵/₈"x47¹/₄"

COLORI COLOURS COULEURS FARBEN

cassero antracite



cassero grigio



cassero beige



rasato antracite

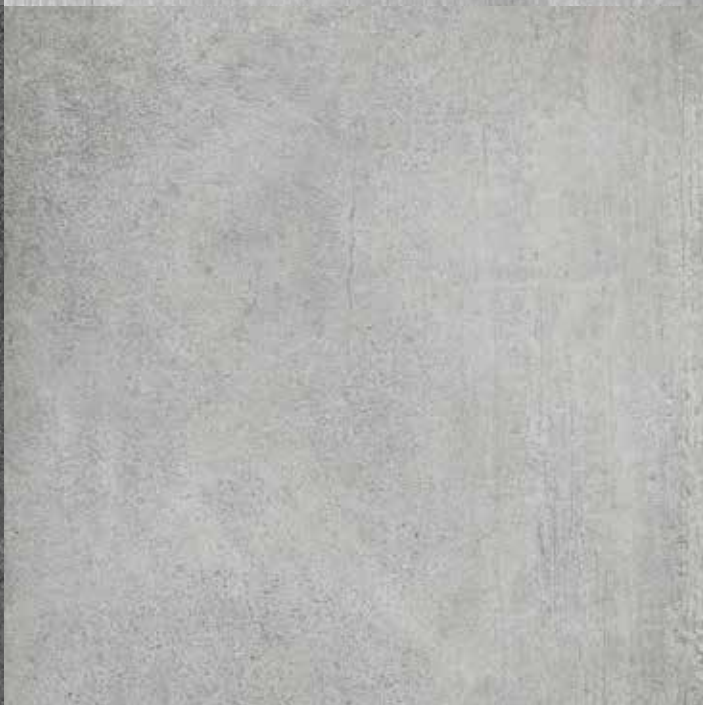

rasato grigio

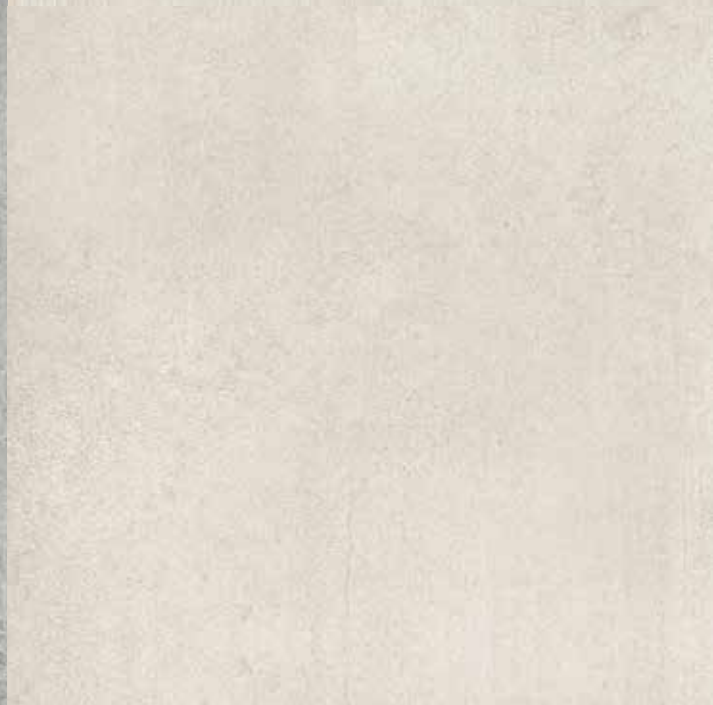

rasato beige

cemento
GRANITOKER

cassero bianco









rasato bianco



rasato grigio cm 60x60 - 23⁵/₈"x23⁵/₈", **cassero grigio** cm 60x120 - 23⁵/₈"x47¹/₄"

FORMATI SIZES FORMATS FORMATE

					
Formati Sizes Formats Formate	cm 30x60 11 ³ / ₄ "x23 ⁵ / ₈ "	cm 60x60 23 ⁵ / ₈ "x23 ⁵ / ₈ "	cm 37,5x75,5 14 ³ / ₄ "x29 ³ / ₄ "	cm 75,5x75,5 29 ³ / ₄ "x29 ³ / ₄ "	cm 60x120 23 ⁵ / ₈ "x47 ¹ / ₄ "
Superfici Surfaces Surfaces Oberflächen	● ●	● ●	● ●	● ●	● ●
Spessori Thicknesses Epaisseurs Stärken	mm 10,5 mm 9,4	mm 10,5	mm 10 mm 9	mm 10	mm 10,5
● Cassero R10 ● Rasato R9			 Media Medium Moyenne Mittel	Caratteristiche tecniche e imballi a pagina Technical features and packing on page Caractéristiques techniques et emballages à la page Technische Eigenschaften und Verpackungen auf Seite 450	

PEZZI SPECIALI TRIMS ACCESSOIRES FORMSTÜCKE

Battiscopa Bullnose
Plinthe à bord arrondi Stehsockel
cm 9x60 - 3¹/₂"x23⁵/₈"
cm 9x75,5 - 3¹/₂"x29³/₄"



Gradino Step tread
Nez de marche Stufenplatte
cm 30x60 - 11³/₄"x23⁵/₈"

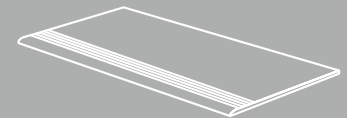

Gradone (assemblato)
cm 60x33 - 23⁵/₈"x13"
cm 120x33 - 47¹/₄"x13"

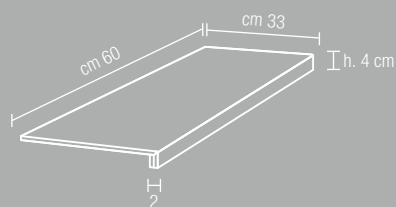

Angolare (assemblato)
cm 60x33 - 23⁵/₈"x13"
cm 120x33 - 47¹/₄"x13"

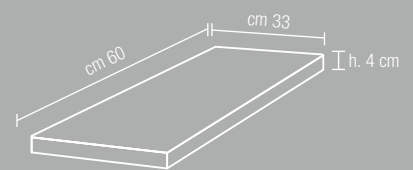

DECORI DECORS DÉCORS DEKORE

cemento
GRANITOKER

composizione A*



cm 30x60 - 11³/₄"x23⁵/₈"
su rete on net sur trame auf Netz
 Solo superficie cassero. Cassero surface only.
 Seulement surface cassero. Nur in der "Cassero" Oberfläche.

rug cemento*

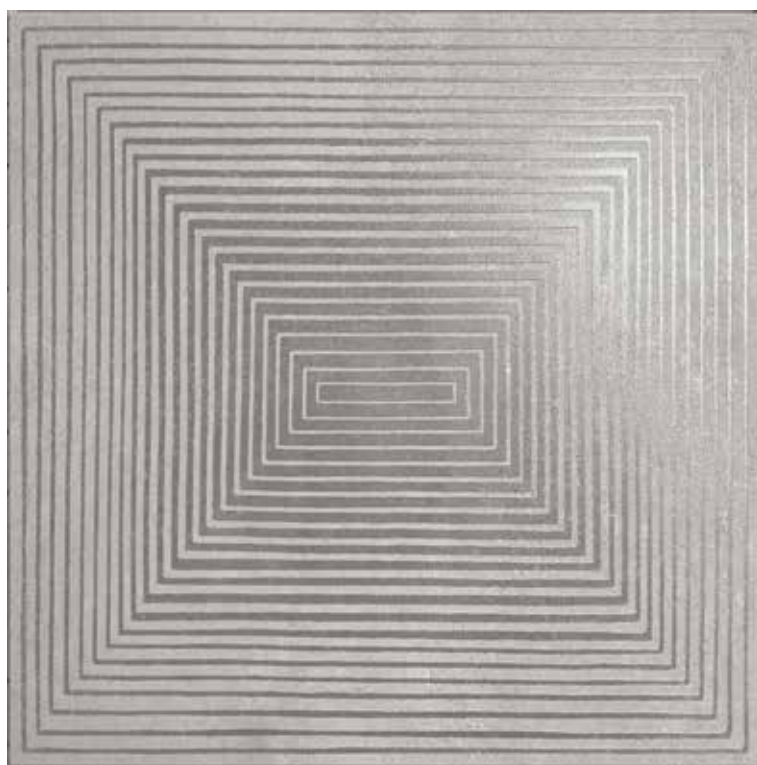

cm 60x60 - 23⁵/₈"x23⁵/₈"
 Solo superficie rasato. Rasato surface only.
 Seulement surface rasato. Nur in der "Rasato" Oberfläche.

* Disponibile in tutti i colori della serie.
 Available in all the colours of the series.
 Disponible dans tous les couleurs de la série.
 Verfügbar in allen farben.



rasato antracite cm 60x120 - 23⁵/₈"x47¹/₄"
 rug cassero cm 60x60 - 23⁵/₈"x23⁵/₈"



rasato beige cm 60x120 - 23⁵/₈"x47¹/₄"
 composizione A beige cm 30x60 - 11³/₄"x 23⁵/₈"

DECORI DECORS DÉCORS DEKORE

quadrotta cemento



cm 25,1x25,1 - 97/8"x97/8"
rasato grigio



cm 25,1x25,1 - 97/8"x97/8"
rasato grigio

mosaico tessuto

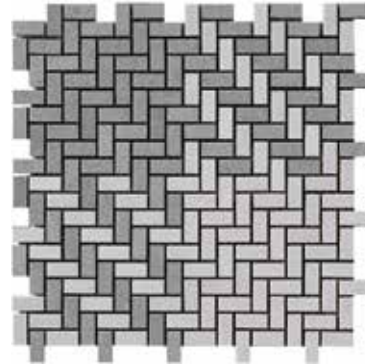

cm 25,1x25,1 - 97/8"x97/8"
1 Rasato Antracite + Rasato Grigio
2 Rasato Grigio + Rasato Bianco

Solo superficie rasato.
Rasato surface only.
Seulement surface rasato.
Nur in der "Rasato" Oberfläche.

* Disponibile in tutti i colori della serie.
Available in all the colours of the series.
Disponibile dans tous les couleurs de la série.
Verfügbar in allen Farben.

listelli cemento*



cm 30x30 - 11³/₄"x11³/₄"
listello 1,4x30 - 1/2"x11³/₄"
su rete on net sur trame auf Netz
Solo superficie cassero.
Cassero surface only.
Seulement surface cassero.
Nur in der "Cassero" Oberfläche.

mosaico cemento*

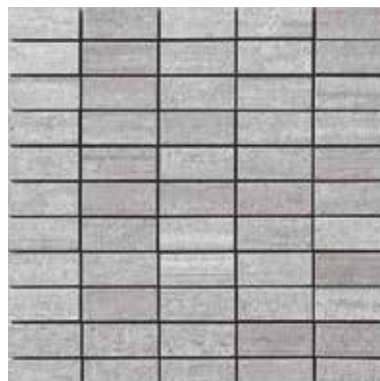

cm 30x30 - 11³/₄"x11³/₄"
tessera cm 5,7x2,5 - 2¹/₄"x1"
su rete on net sur trame auf Netz
Solo superficie cassero.
Cassero surface only.
Seulement surface cassero.
Nur in der "Cassero" Oberfläche.

mosaico 6x6*



cm 30x30 - 11³/₄"x11³/₄"
tessera cm 6x6 - 2³/₈"x2³/₈"
su rete on net sur trame auf Netz
Superficie cassero e rasato.
Cassero and rasato surface.
Surface cassero et rasato.
Nur in der "cassero" und "rasato" Oberfläche.



cemento
GRANITOKER

rasato grigio, cassero grigio cm 60x120 - 23⁵/₈"x47¹/₄"
listelli cemento grigio cm 30x30 - 11³/₄"x11³/₄"

resina
GRANITOKER



havana cm 90x180 - 35³/₈"x70⁷/₈", **white** cm 90x180 - 35³/₈"x70⁷/₈"

COLORI COLOURS COULEURS FARBEN

black



havana



tobacco



grey



white



resina
GRANITOKER

black cm 90x180 - 35³/₈"x70⁷/₈", 45x90 - 17³/₄"x35³/₈" / 90x90 - 35³/₈" 35³/₈"

| BETON

| CEMENTO

| **RESINA**

| SPAZIO

| ECONCRETE

| LOFT

| FEEL





| LIVING

| VENEZIA

| OLD SEASON

| COTTO CERATO

FORMATI SIZES FORMATS FORMATE

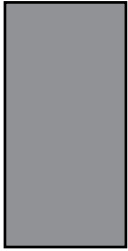
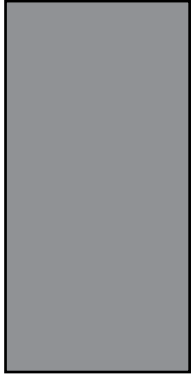
						
Formati Sizes Formats Formate	cm 30x60 11 ³ / ₄ "x23 ⁵ / ₈ "	cm 60x60 23 ⁵ / ₈ "x23 ⁵ / ₈ "	cm 45x90 17 ³ / ₄ "x35 ³ / ₈ "	cm 90x90 35 ³ / ₈ "x35 ³ / ₈ "	cm 60x120 23 ⁵ / ₈ "x47 ¹ / ₄ "	cm 90x180 35 ³ / ₈ "x70 ⁷ / ₈ "
Superfici Surfaces Surfaces Oberflächen	●	●	●	●	●	●
Spessori Thicknesses Epaisseurs Stärken	mm 10	mm 10	mm 10	mm 10	mm 10	mm 10

● Naturale Matt Naturelle Matt **R9**



Leggera
Subtle
Légère
Leicht

Caratteristiche tecniche e imballi a pagina
Technical features and packing on page
Caractéristiques techniques et emballages à la page
Technische Eigenschaften und Verpackungen auf Seite
450

PEZZI SPECIALI TRIMS ACCESSOIRES FORMSTÜCKE

Battiscopa Bullnose
Plinthe à bord arrondi Stehsockel
cm 9x90 - 3¹/₂"x35³/₈"



Gradino Step tread
Nez de marche Stufenplatte
cm 30x90 - 11³/₄"x35³/₈"



Gradone (assemblato)
cm 90x33 - 35³/₈"x13"

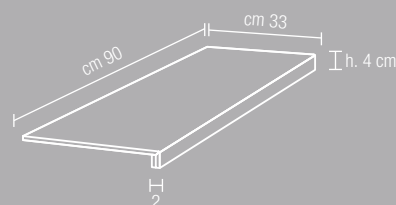

Angolare (assemblato)
cm 90x33 - 35³/₈"x13"

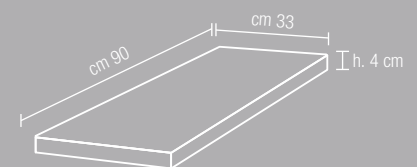

DECORI DECORS DÉCORS DEKORE

resina
GRANITOKER

mosaico 6x6*



cm 30x30 - 11³/₄"x11³/₄"
 tessera cm 6x6 - 2³/₈"x2³/₈"
su rete on net sur trame auf Netz

mosaico penta



cm 31,6x63,2 - 12¹/₂"x23⁷/₈"
Combinazione di Black + Havana + Tobacco

composizione D*



cm 28,5x57,6 - 11¹/₄"x22⁵/₈"
 mattoncino cm 7x28 - 2³/₄"x11¹/₄"
su rete on net sur trame auf Netz

coprispigolo*



cm 45x1,2 - 17³/₄"x³/₈"

fascia resina*



cm 22,5x90 - 8⁷/₈"x35³/₈"

* Disponibile in tutti i colori della serie.
 Available in all the colours of the series.
 Disponible dans tous les couleurs de la série.
 Verfügbar in allen Farben.

spazio
PIETRE NATIVE



antracite cm 60x60 - 23⁵/₈"x23⁵/₈"

antracite

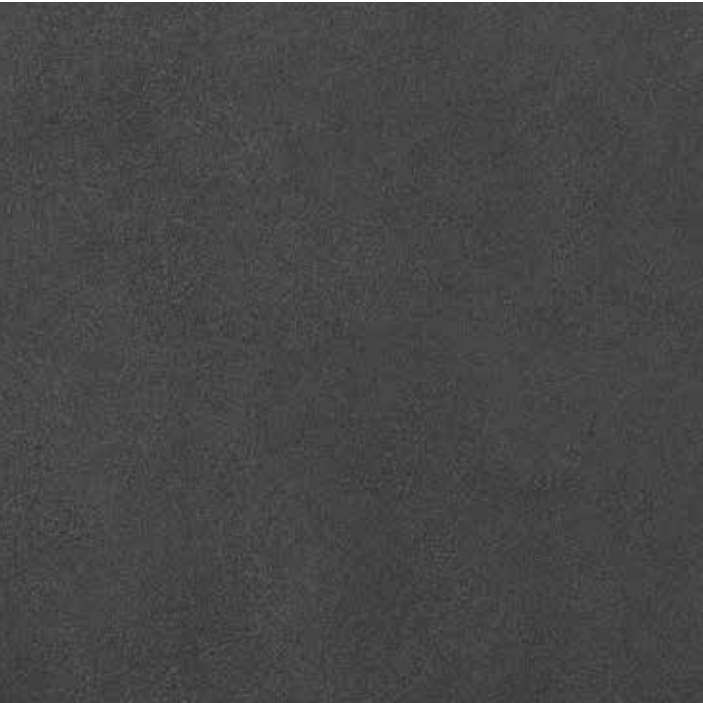

bronzo

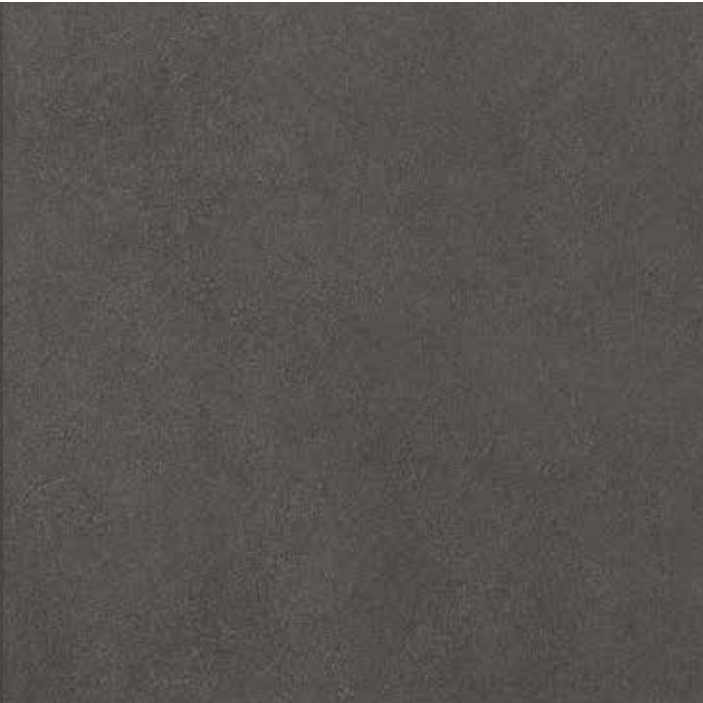

tabacco



perla

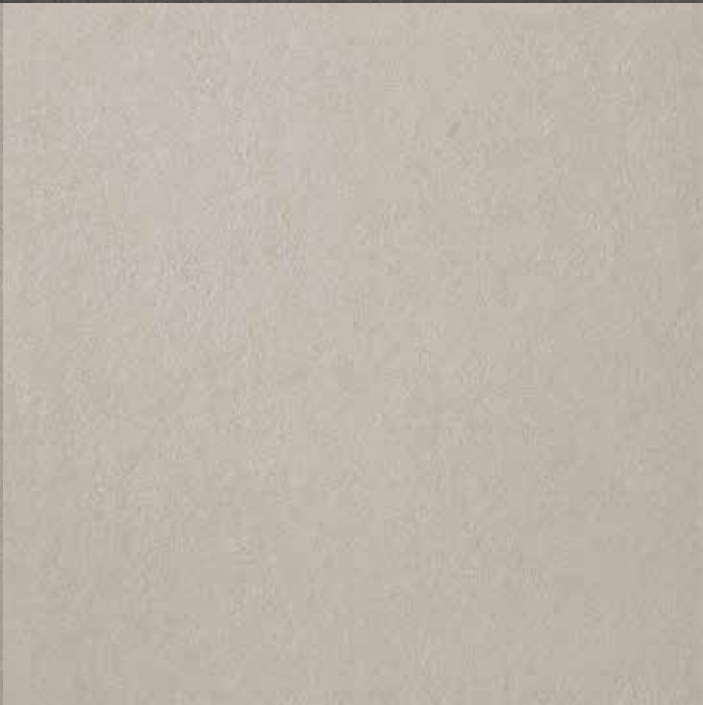

argento

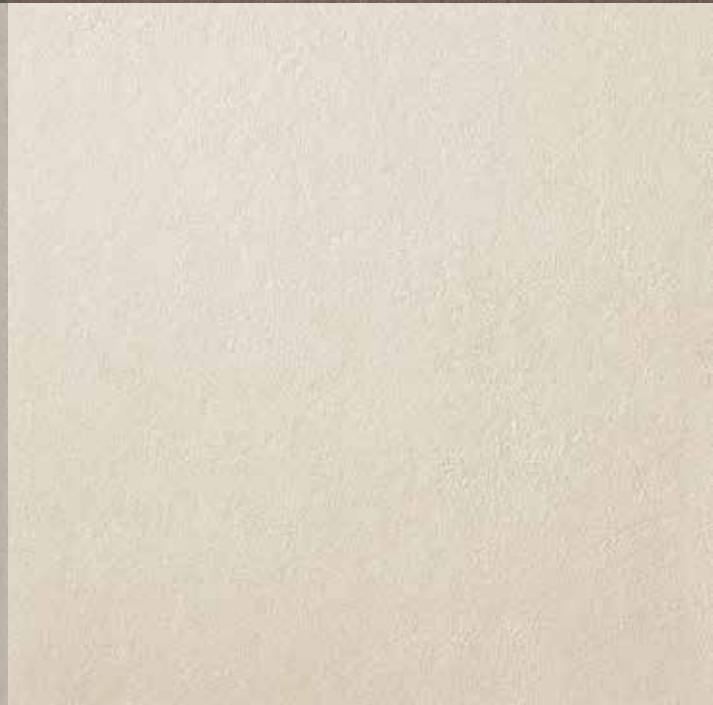

beige

spazio

PIETRE NATIVE

tortora

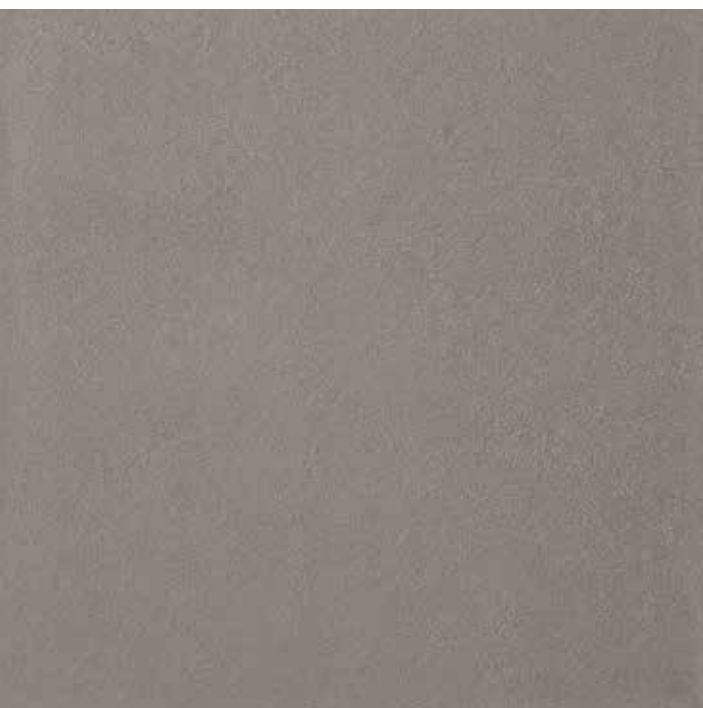

grigio

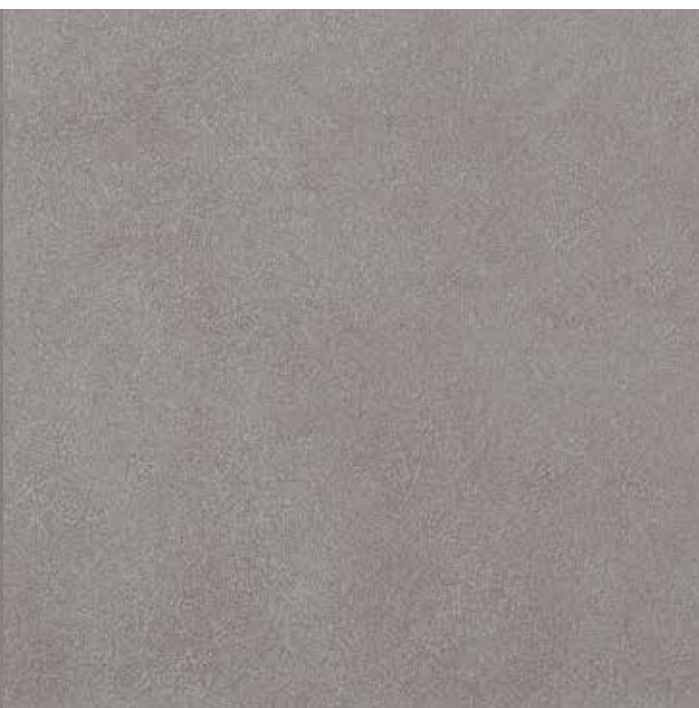

beige cm 30x60 - 11³/₄"x23⁵/₈",
60x60 - 23⁵/₈"x23⁵/₈"

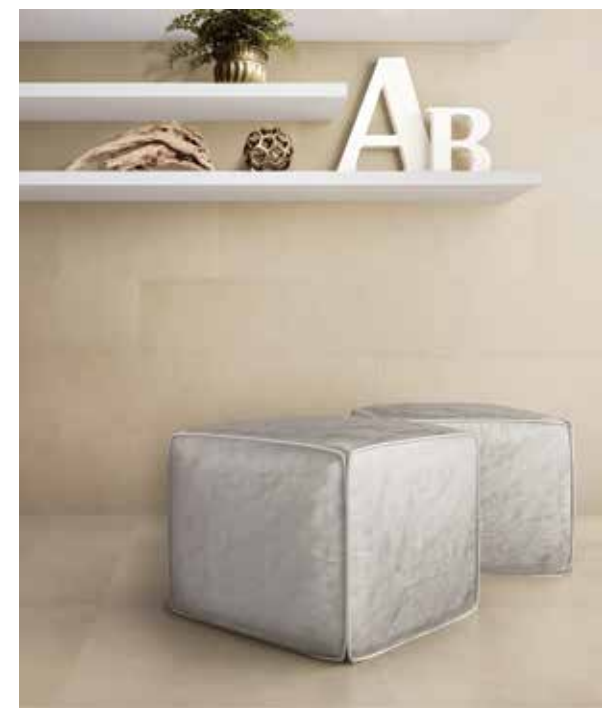

bianco



tabacco cm 60x60 - 23⁵/₈"x23⁵/₈"

FORMATI SIZES FORMATS FORMATE

Formati Sizes Formats Formate	cm 30x30 11 ³ / ₄ "x11 ³ / ₄ "	cm 45x45 17 ³ / ₄ "x17 ³ / ₄ "	cm 30x60 11 ³ / ₄ "x23 ⁵ / ₈ "	cm 60x60 23 ⁵ / ₈ "x23 ⁵ / ₈ "	cm 37,5x75,5 14 ³ / ₄ "x29 ³ / ₄ "	cm 75,5x75,5 29 ³ / ₄ "x29 ³ / ₄ "
Superfici Surfaces Surfaces Oberflächen	●	●	●	●	●	●
Spessori Thicknesses Epaisseurs Stärken	mm 9,4	mm 9	mm 10 mm 9,4	mm 10	mm 10	mm 10
● Naturale Matt Naturelle Matt R10						
				 Leggera Subtle Légère Leicht	Caratteristiche tecniche e imballi a pagina Technical features and packing on page Caractéristiques techniques et emballages à la page Technische Eigenschaften und Verpackungen auf Seite 448	

PEZZI SPECIALI TRIMS ACCESSOIRES FORMSTÜCKE

Battiscopa Bullnose
Plinthe à bord arrondi Stehsockel
 cm 9x30 - 3¹/₂"x11³/₄"
 cm 9x45 - 3¹/₂"x17³/₄"
 cm 9x60 - 3¹/₂"x23⁵/₈"
 cm 9x75,5 - 3¹/₂"x29³/₄"



Gradino Step tread
Nez de marche Stufenplatte
 cm 30x30 - 11³/₄"x11³/₄"
 cm 30x45 - 11³/₄"x17³/₄"
 cm 30x60 - 11³/₄"x23⁵/₈"

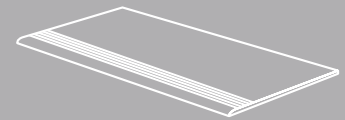

Gradone (assemblato)
 cm 60x33 - 23⁵/₈"x13"

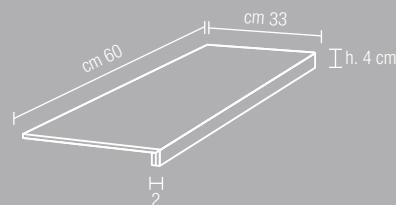

Angolare (assemblato)
 cm 60x33 - 23⁵/₈"x13"

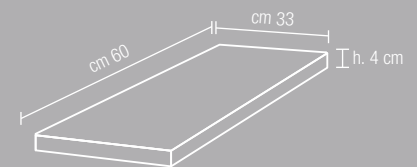

Tozzetto Insert
Cabochon Einleger
 cm 9x9 3¹/₂"x3¹/₂"



Listello Listel
Listel Zeilerleiste
 cm 9x30 3¹/₂"x11³/₄"



Terminale
Pezzo incollato Glued piece
Pièce collée Geklebter Stück
 cm 15x30x5 - 5⁷/₈"x11³/₄"x2"

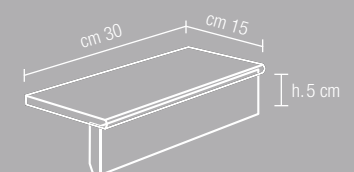

DECORI DECORS DÉCORS DEKORE

spazio
PIETRE NATIVE

mix listelli spazio A



cm 30x30 - 11³/₄"x11³/₄"
listello cm 1,4x30 - 1/2"x11³/₄"
su rete on net sur trame auf Netz
bianco, argento, grigio

mix listelli spazio B



cm 30x30 - 11³/₄"x11³/₄"
listello cm 1,4x30 - 1/2"x11³/₄"
su rete on net sur trame auf Netz
antracite, grigio, bianco, argento

mix listelli spazio C



cm 30x30 - 11³/₄"x11³/₄"
listello cm 1,4x30 - 1/2"x11³/₄"
su rete on net sur trame auf Netz
beige, tortora, perla

mix listelli spazio D



cm 30x30 - 11³/₄"x11³/₄"
listello cm 1,4x30 - 1/2"x11³/₄"
su rete on net sur trame auf Netz
bronzo, antracite, tabacco



bianco cm 60x60 - 23⁵/₈"x23⁵/₈"



mix listelli spazio C cm 30x30 - 11³/₄"x11³/₄",
beige cm 30x30 - 11³/₄"x11³/₄", 60x60 - 23⁵/₈"x23⁵/₈"



econcrete
GRESPLUS



grigio cm 60x60 - 23⁵/₈"x23⁵/₈"

antracite



beige



cenere



grigio



bianco

econcrete
GRESPLUS

Formati Sizes
Formats Formate



cm 30x60
11³/₄"x23⁵/₈"



cm 60x60
23⁵/₈"x23⁵/₈"

Superfici Surfaces
Surfaces Oberflächen



Spessori Thicknesses
Epaisseurs Stärken

mm 9

mm 9

- Naturale Matt Naturelle Matt **R10 A+B**
- Grip **R11 A+B**

Caratteristiche tecniche e imballi a pagina
Technical features and packing on page
Caractéristiques techniques et emballages à la page
Technische Eigenschaften und Verpackungen auf Seite
452

PEZZI SPECIALI TRIMS ACCESSOIRES FORMSTÜCKE

Battiscopa Bullnose
Plinthe à bord arrondi Stehsockel
cm 9x60 - 3¹/₂"x23⁵/₈"



Gradino Step tread
Nez de marche Stufenplatte
cm 30x60- 11³/₄"x23⁵/₈"

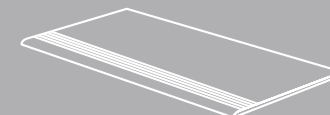

beige cm 30x60 - 11³/₄"x23⁵/₈"

loft
GRANITOKER



nero cm 60x60 - 23⁵/₈"x 23⁵/₈"

COLORI COLOURS COULEURS FARBEN

nero



grigio



bianco



rosso



moka



avorio

loft

GRANITOKER

rosso cm 60x60 - 23⁵/₈"x23⁵/₈"

| BETON

| CEMENTO

| RESINA

| SPAZIO

| ECONCRETE

| LOFT

| FEEL



| LIVING

| VENEZIA

| OLD SEASON

| COTTO CERATO

FORMATI SIZES FORMATS FORMATE

Formati Sizes Formats Formate	 cm 30x60 11 ³ / ₄ "x23 ⁵ / ₈ "	 cm 60x60 23 ⁵ / ₈ "x23 ⁵ / ₈ "
Superfici Surfaces Surfaces Oberflächen	●	●
Spessori Thicknesses Epaisseurs Stärken	mm 10,5	mm 10,5
● Naturale Matt Naturelle Matt R9	Caratteristiche tecniche e imballi a pagina Technical features and packing on page Caractéristiques techniques et emballages à la page Technische Eigenschaften und Verpackungen auf Seite 450	

PEZZI SPECIALI TRIMS ACCESSOIRES FORMSTÜCKE

Battiscopa Bullnose
Plinthe à bord arrondi Stehsockel
 cm 9x60 - 3¹/₂"x23⁵/₈"



Gradino Step tread
Nez de marche Stufenplatte
 cm 30x60 - 11³/₄"x23⁵/₈"

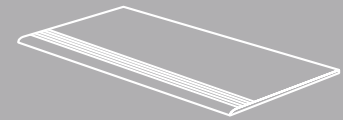

DÉCORS DEKORE

loft
GRANITOKER

decoro loft grigio (● nero)



cm 60x60 - 23⁵/₈"x23⁵/₈"
su rete on net sur trame auf Netz

decoro loft nero (● grigio)

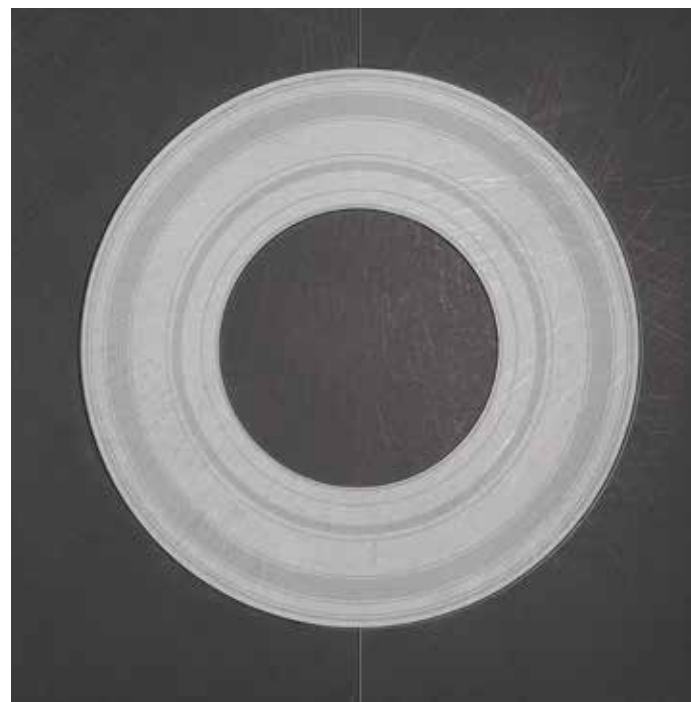

cm 60x60 - 23⁵/₈"x23⁵/₈"
su rete on net sur trame auf Netz

decoro loft avorio (● moka)



cm 60x60 - 23⁵/₈"x23⁵/₈"
su rete on net sur trame auf Netz

decoro loft moka (● avorio)



cm 60x60 - 23⁵/₈"x23⁵/₈"
su rete on net sur trame auf Netz

feel
ECOGRES



grey cm 41,5x41,5 - 16³/₈"x16³/₈"

COLORI COLOURS COULEURS FARBEN

black



grey



silver



olive

beige





white



FORMATI SIZES FORMATS FORMATE

feel
ECOGRES

Formati Sizes Formats Formate	 cm 33x33 13"x13"	 cm 41,5x41,5 16 ³ / ₈ "x16 ³ / ₈ "	 cm 30x60 11 ³ / ₄ "x23 ⁵ / ₈ "
Feel Black G3*	●	●	●
Feel Grey G3*	●	●	●
Feel Silver G4*	●	●	●
Feel Olive G4*	●	●	●
Feel Beige G4*	●	●	●
Feel White G4*	●	●	●
Spessori Thicknesses Epaisseurs Stärken	mm 8,2	mm 8,8	mm 9

- Naturale Matt Naturelle Matt **R9**

* Vedi pagina See page
Voire page Siehe Seite
455

Caratteristiche tecniche e imballi a pagina
Technical features and packing on page
Caractéristiques techniques et emballages à la page
Technische Eigenschaften und Verpackungen auf Seite
454

PEZZI SPECIALI TRIMS ACCESSOIRES FORMSTÜCKE

Battiscopa Bullnose
Plinthe à bord arrondi Stehsockel
cm 8x33 - 3¹/₂"x13"
cm 8x41,5 - 3¹/₂"x16³/₈"
cm 9x60 - 3¹/₂"x23⁵/₈"



Gradino Step tread
Nez de marche Stufenplatte
cm 33x33 - 13"x13"

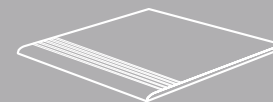

Gradino
cm 30x60 - 11³/₄"x23⁵/₈"



living
ECOGRES



brown cm 33x33 - 13"x13"

COLORI COLOURS COULEURS FARBEN

black



brown



grey



beige

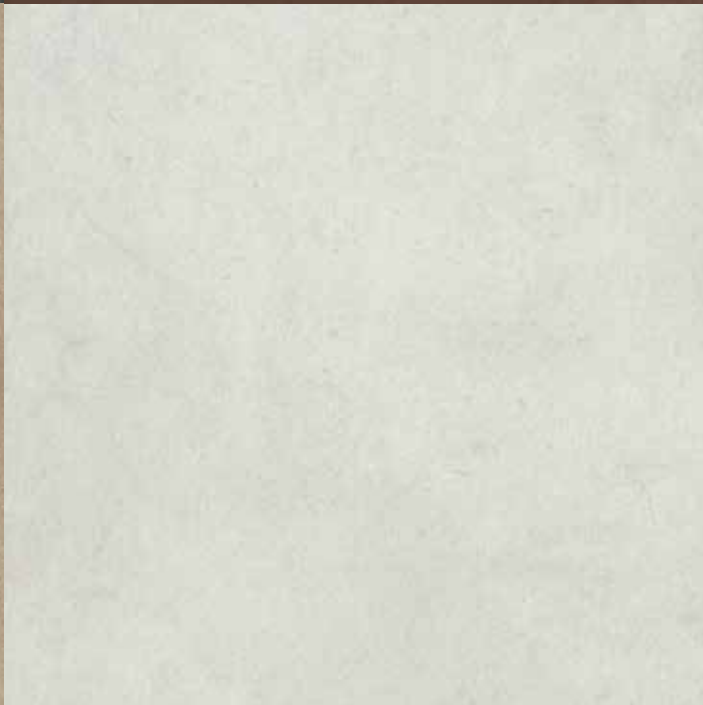

ice

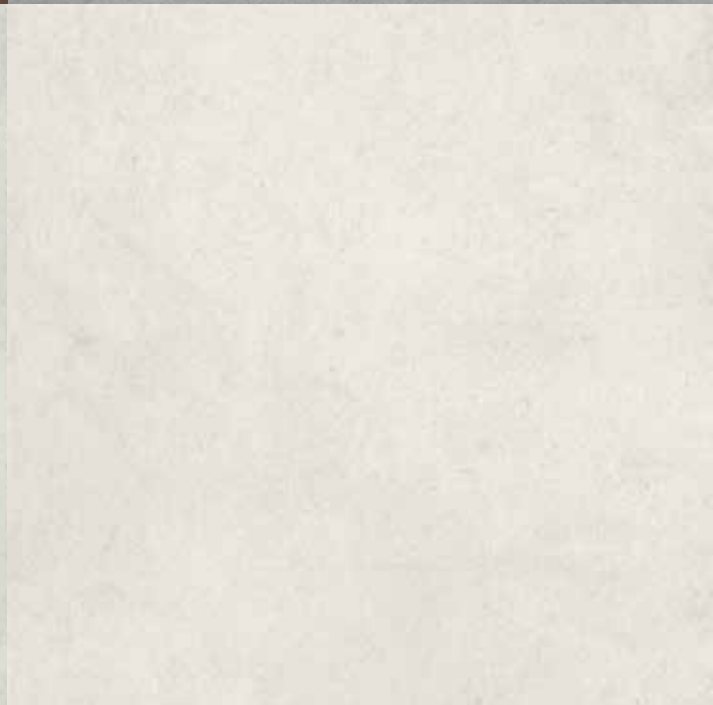

white

FORMATI SIZES FORMATS FORMATE

living
ECOGRES

noisette

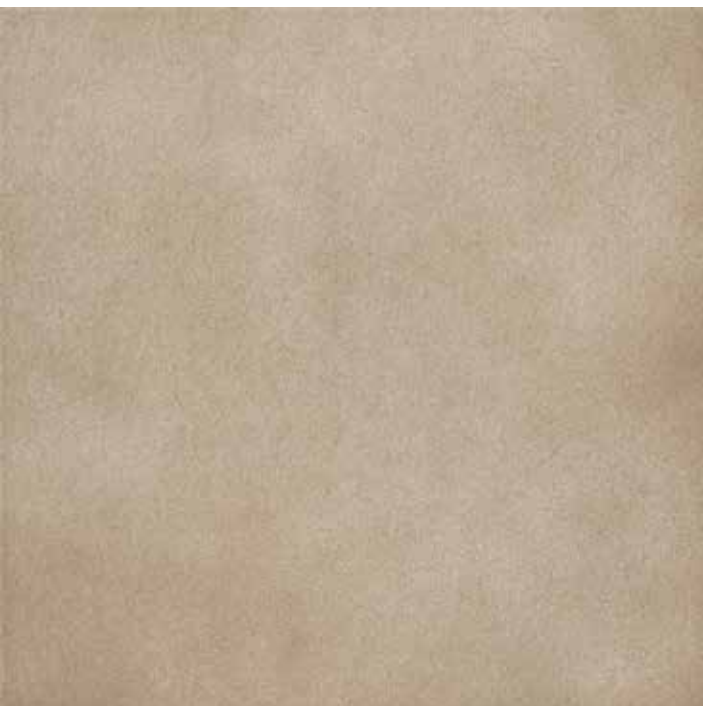

Formati Sizes Formats Formate	cm 33x33 13"x13"	cm 41,5x41,5 16 ³ / ₈ "x16 ³ / ₈ "	cm 30x60 11 ³ / ₄ "x23 ⁵ / ₈ "	cm 60x60 23 ⁵ / ₈ "x23 ⁵ / ₈ "
Living Black G3*	●	●	●	●
Living Brown G3*	●	●	●	●
Living Grey G4*	●	●	●	●
Living Noisette G4*	●	●	●	●
Living Beige G4*	●	●	●	●
Living Ice G4*	●	●	●	●
Living White G4*	●	●	●	●
Spessori Thicknesses Epaisseurs Stärken	mm 8,2	mm 8,8	mm 9	mm 9,5

- Naturale Matt Naturelle Matt **R9**

* Vedi pagina See page
Voire page Siehe Seite
455

Caratteristiche tecniche e imballi a pagina
Technical features and packing on page
Caractéristiques techniques et emballages à la page
Technische Eigenschaften und Verpackungen auf Seite
454

Nel caso di combinazioni di formati di spessori diversi, specificarlo espressamente nell'ordine.
Please specify in your order if you wish to purchase formats including more than one thickness.
Prière de spécifier dans votre commande si vous souhaitez acheter des formats avec différentes épaisseurs.
Bitte weisen Sie im Bestellungsformular ausdrücklich darauf hin, wenn Sie Formatkombinationen mit verschiedenen Stärken wünschen.

PEZZI SPECIALI TRIMS ACCESSOIRES FORMSTÜCKE

Battiscopa Bullnose
Plinthe à bord arrondi Stehsockel
cm 8x33 - 3¹/₂"x13"
cm 8x41,5 - 3¹/₂"x16³/₈"
cm 9x60 - 3¹/₂"x23⁵/₈"



Gradino Step tread
Nez de marche Stufenplatte
cm 33x33 - 13"x13"

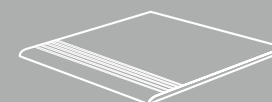

Gradino
cm 30x60 - 11³/₄"x23⁵/₈"



venezia
ECOGRES

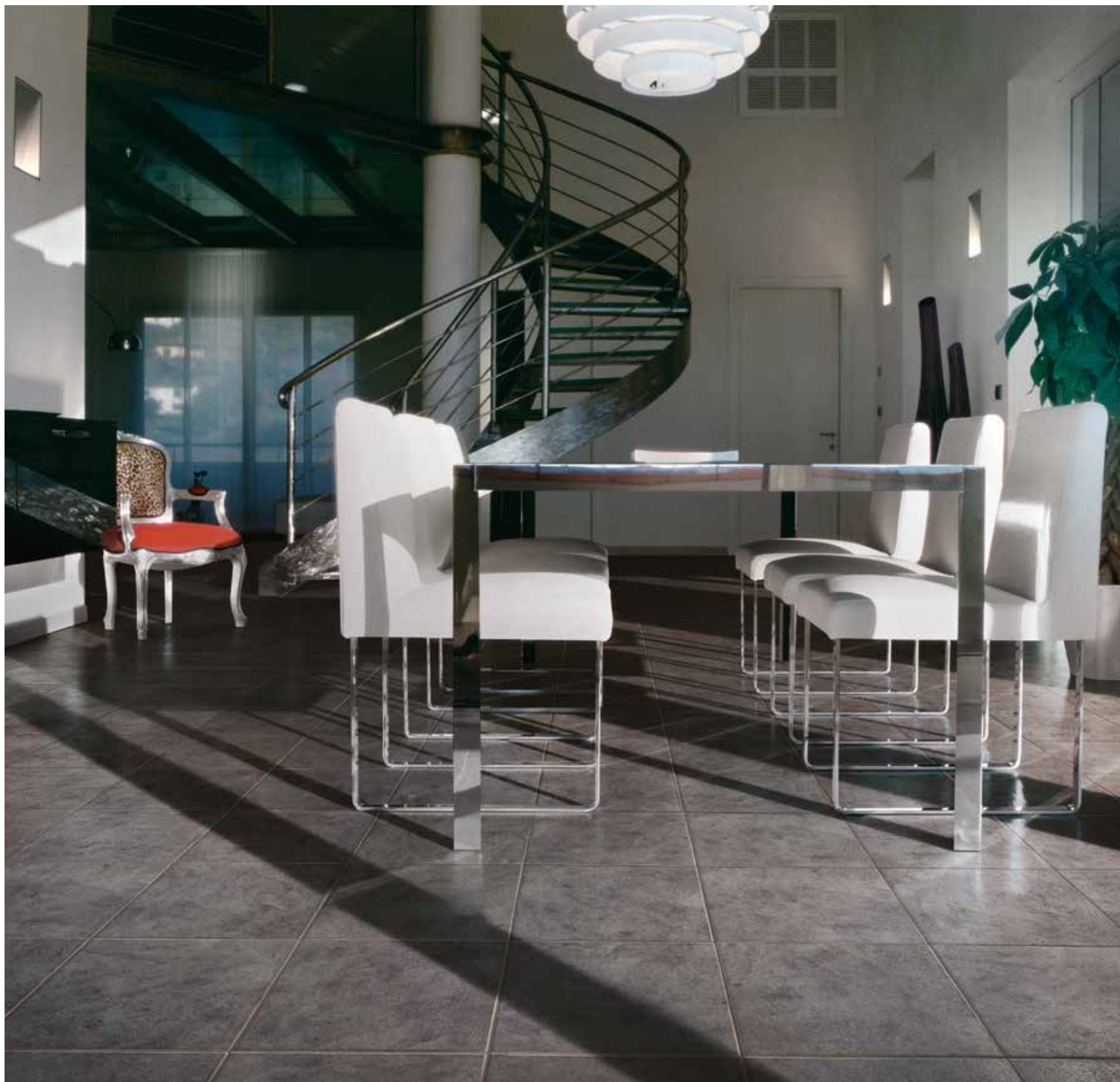

rialto cm 33x33 - 13"x13"

COLORI COLOURS COULEURS FARBEN

rialto



canalgrande





lido

san marco

FORMATI SIZES FORMATS FORMATE

venezia
ECOGRES

Formati Sizes Formats Formate	 cm 33x33 13"x13"	 cm 41,5x41,5 16 ³ / ₈ "x16 ³ / ₈ "
Rialto G3*	●	●
Canalgrande G3*	●	●
Lido G4*	●	●
San Marco G4*	●	●
Spessori Thicknesses Epaisseurs Stärken	mm 8,2	mm 8,8
● Naturale Matt Naturelle Mat	Caratteristiche tecniche e imballi a pagina Technical features and packing on page Caractéristiques techniques et emballages à la page Technische Eigenschaften und Verpackungen auf Seite 454	
* Vedi pagina See page Voire page Siehe Seite 455		

PEZZI SPECIALI TRIMS ACCESSOIRES FORMSTÜCKE

Battiscopa Bullnose
Plinthe à bord arrondi Stehsockel
cm 8x33 - 3¹/₂"x13"
cm 8x41,5 - 3¹/₂"x16³/₈"



Gradino Step tread
Nez de marche Stufenplatte
cm 33x33 - 13"x13"

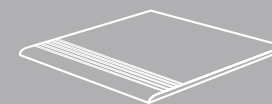

old season

GRESPLUS

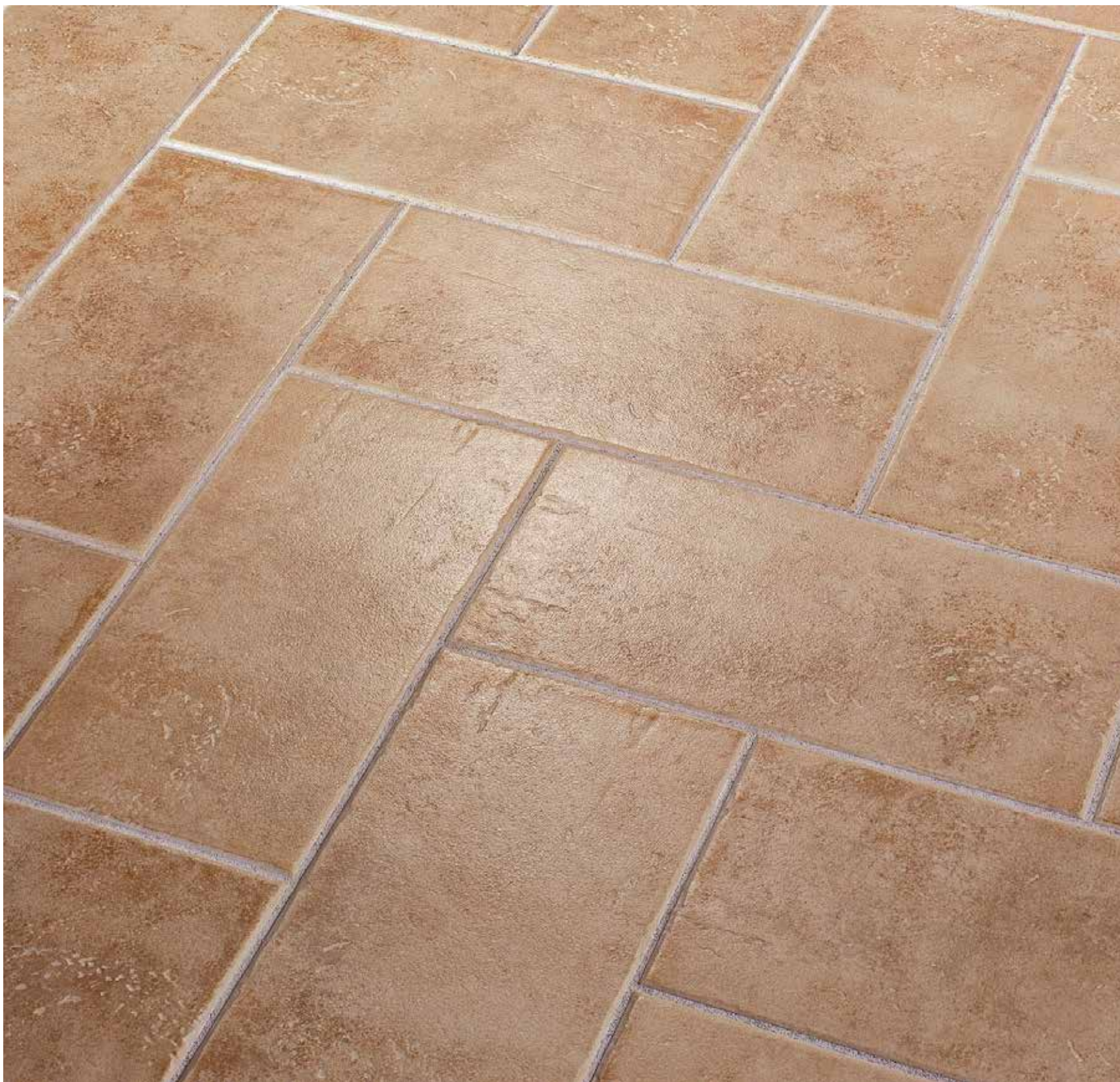

spring cm 15x30 - 5⁷/₈"x11³/₄"

COLORI COLOURS COULEURS FARBEN

summer

winter



autumn

spring

FORMATI SIZES FORMATS FORMATE

old season
GRESPLUS

Formati Sizes Formats Formate	 cm 15x30 5 ⁷ / ₈ "x 11 ³ / ₄ "	 cm 30x30 11 ³ / ₄ "x11 ³ / ₄ "
Summer G4*	●	●
Winter G4*	●	●
Autumn G4*	●	●
Spring G4*	●	●
Spessori Thicknesses Epaisseurs Stärken	mm 8	mm 8,2

● Naturale Matt Naturelle Mat

* Vedi pagina See page
Voire page Siehe Seite
453

Caratteristiche tecniche e imballi a pagina
Technical features and packing on page
Caractéristiques techniques et emballages à la page
Technische Eigenschaften und Verpackungen auf Seite
452

PEZZI SPECIALI TRIMS ACCESSOIRES FORMSTÜCKE

Battiscopa Bullnose
Plinthe à bord arrondi Stehsockel
cm 9x30 - 3¹/₂"x11³/₄"



Gradino Step tread
Nez de marche Stufenplatte
cm 30x30 - 11³/₄"x11³/₄"



Gradone
Pezzo incollato Glued piece
Piece collee Geklebter Stück
cm 30x33 - 3¹/₂"x13"

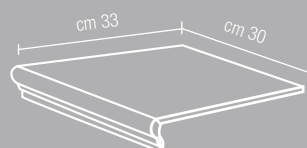

Gradone angolare
Pezzo incollato Glued piece
Piece collee Geklebter Stück
cm 33x33 - 13"x13"

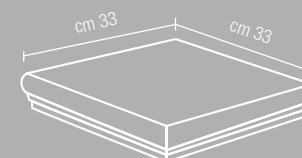

cotto cerato

GRESPLUS

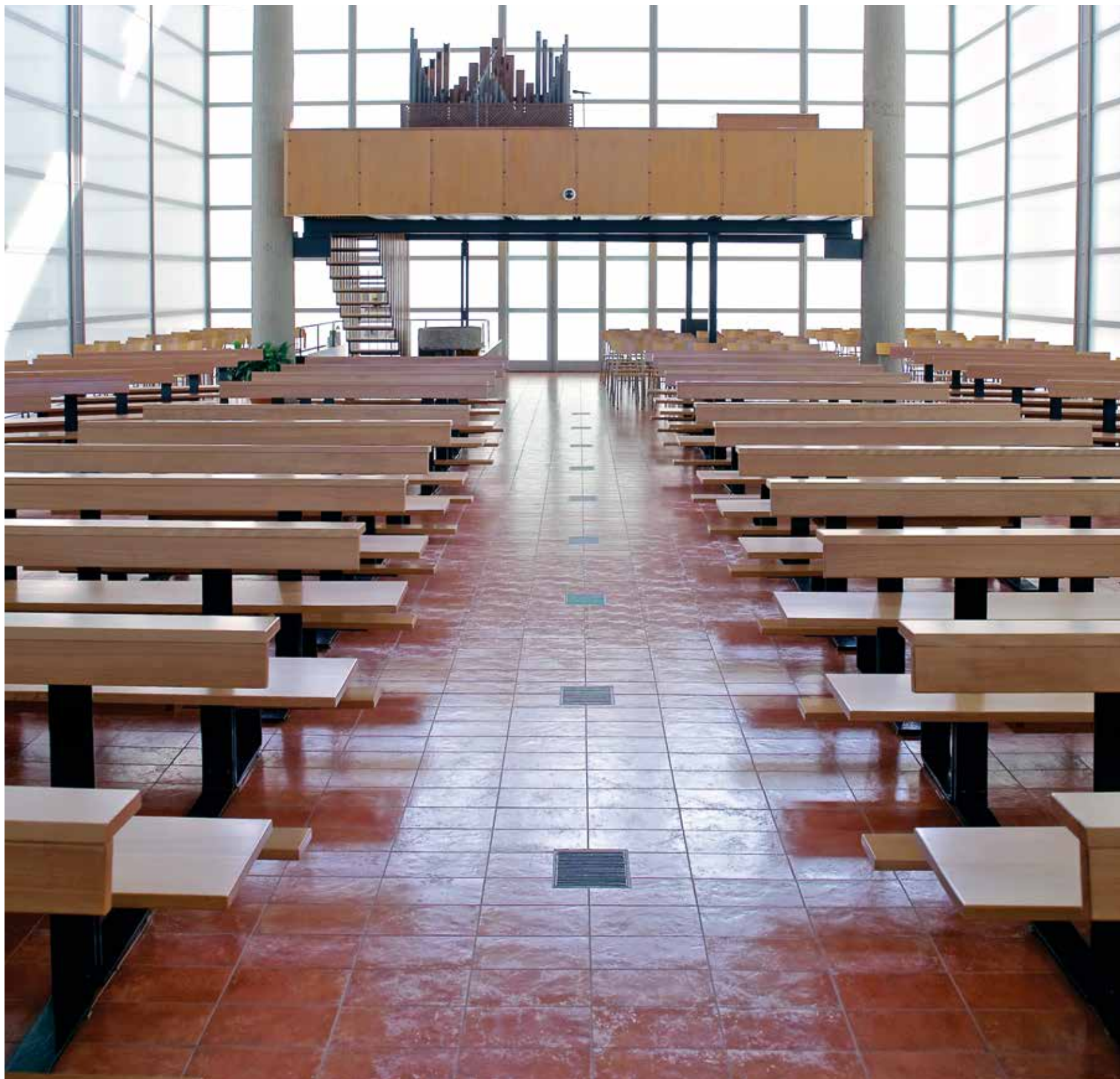

cotto ramato

COLORI COLOURS COULEURS FARBEN

cotto rosato



cotto ramato



cotto paglierino

FORMATI SIZES FORMATS FORMATE

cotto cerato
GRESPLUS



cm 30x30
11³/₄"x11³/₄"

Formati Sizes
Formats Formate

Cotto Rosato G4*

Cotto Ramato G4*

Cotto Paglierino G4*



Spessori Thicknesses
Epaisseurs Stärken

mm 8,2

● Naturale Matt Naturelle Mat

* Vedi pagina See page
Voire page Siehe Seite
453

Caratteristiche tecniche e imballi a pagina
Technical features and packing on page
Caractéristiques techniques et emballages à la page
Technische Eigenschaften und Verpackungen auf Seite
452

PEZZI SPECIALI TRIMS ACCESSOIRES FORMSTÜCKE

Battiscopa Bullnose
Plinthe à bord arrondi Stehsockel
cm 9x30 - 3¹/₂"x11³/₄"



Gradino Step tread
Nez de marche Stufenplatte
cm 30x30 - 11³/₄"x11³/₄"



Gradone
Pezzo incollato Glued piece
Piece collee Geklebter Stück
cm 30x33 - 3¹/₂"x13"

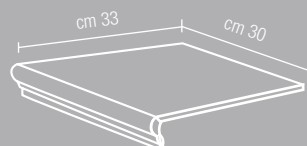

Gradone angolare
Pezzo incollato Glued piece
Piece collee Geklebter Stück
cm 33x33 - 13"x13"

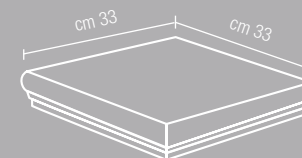

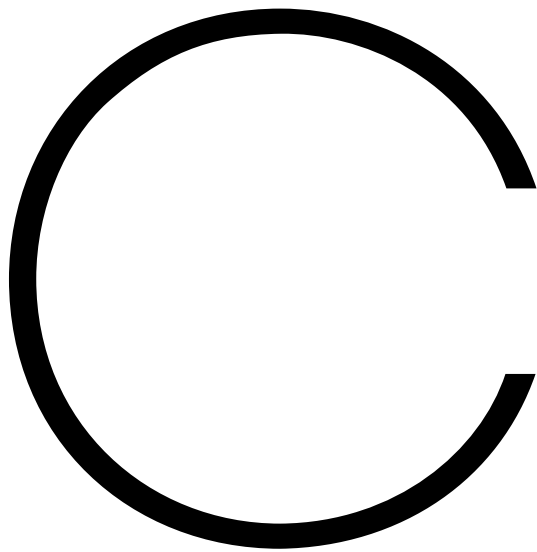
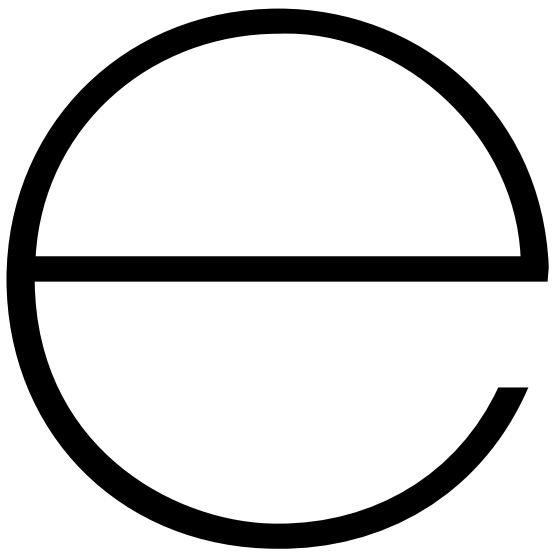

eco**technique** éco**technique** öko**technik**

tecnico

eco**tecnico**

426 **technic**

436 **tactile**

TECNICO

Materiale, prodotto, componente dotato di proprietà e caratteristiche prestazionali individuate o definite in rapporto alla sua origine e all'impiego a cui è destinato, che ne determinano il livello e il conseguente grado di specializzazione. Le proprietà e le caratteristiche sono valutabili secondo unità di misura, grandezze, capacità e procedure di prova rilevabili attraverso specifiche unanimemente condivise.

TECHNICAL

Material, product or component possessing properties and performance specifications identified or defined depending on their origin and the use for which they have been designed, and that determine their level and consequent degree of specialisation. The properties and characteristics can be evaluated according to units of measurement, magnitudes, capacities and test procedures established by universally accepted specifications.





technic
GRANITOGRES



nebraska cm 20x20 - 7⁷/₈"x7⁷/₈"

COLORI COLOURS COULEURS FARBEN

grigio cenere



bianco avorio



bianco B



colorado



sahara



nebraska

technic
GRANITOGRES

ontario



labrador



arkansas



georgia

SERIE LANDSCAPE

Landscape tundra 100 satin lucida

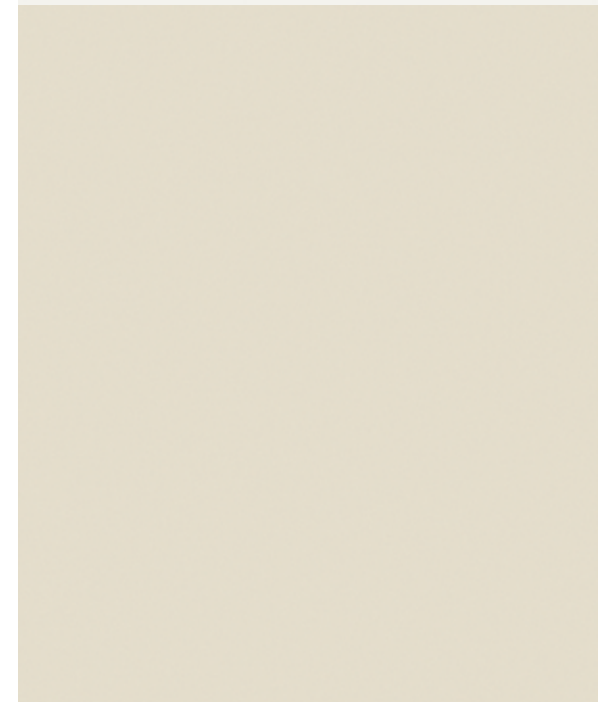
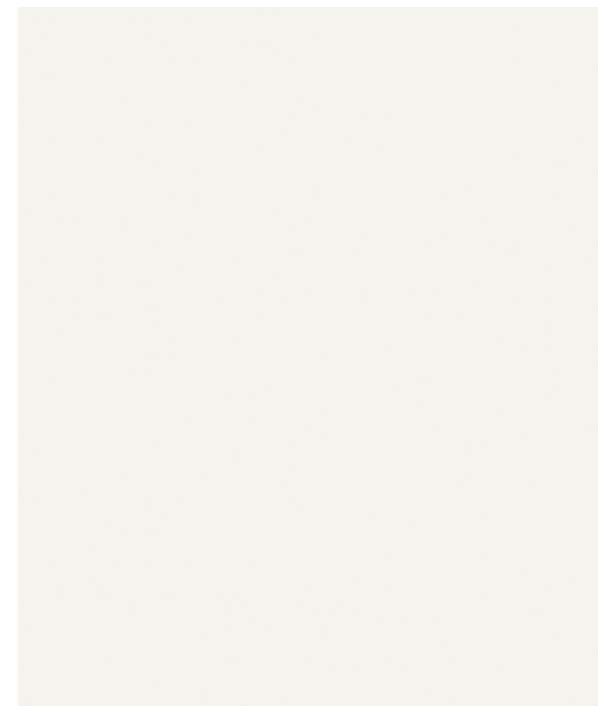

Landscape beach 101 satin

Rivestimenti smaltati
Glazed tiles
Revêtement émaillé
Fliesen aus glasiertem Feinsteinzeug

SUPERFICI SURFACES SURFACES OBERFLÄCHEN

technic R10

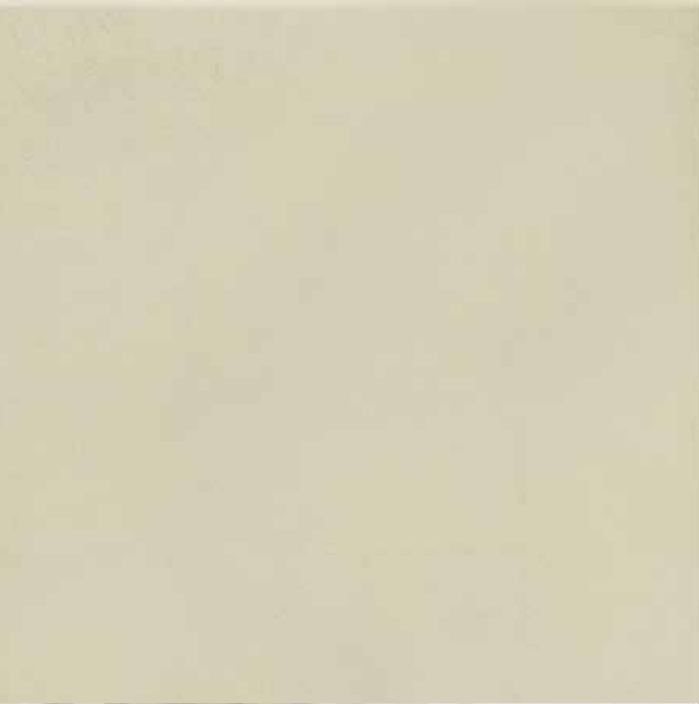

roccia R12 (A+B+C)



profil R12 - V8 (A+B+C)

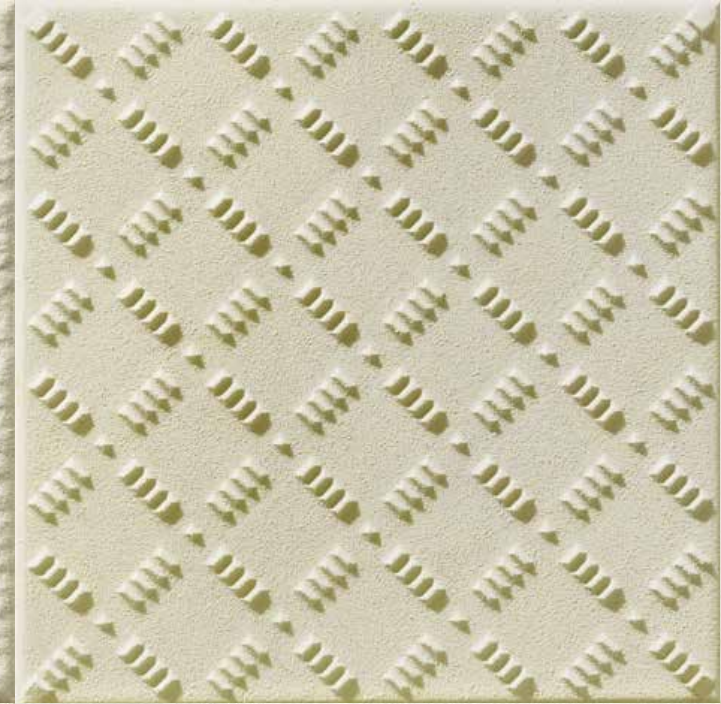

reticolo R12 - V4 (A+B+C)



carbo R12

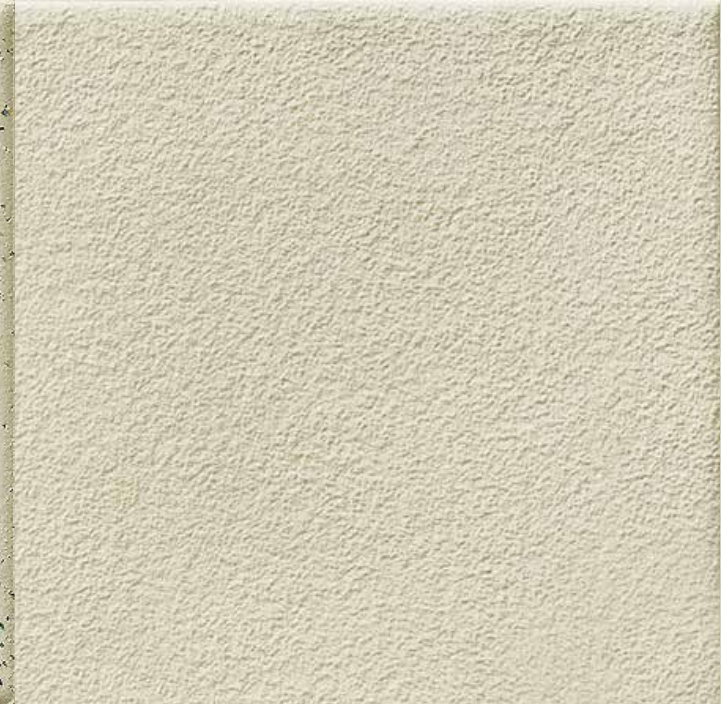

secura R11 (A+B)

bugnato R11 - V6 (A+B+C)

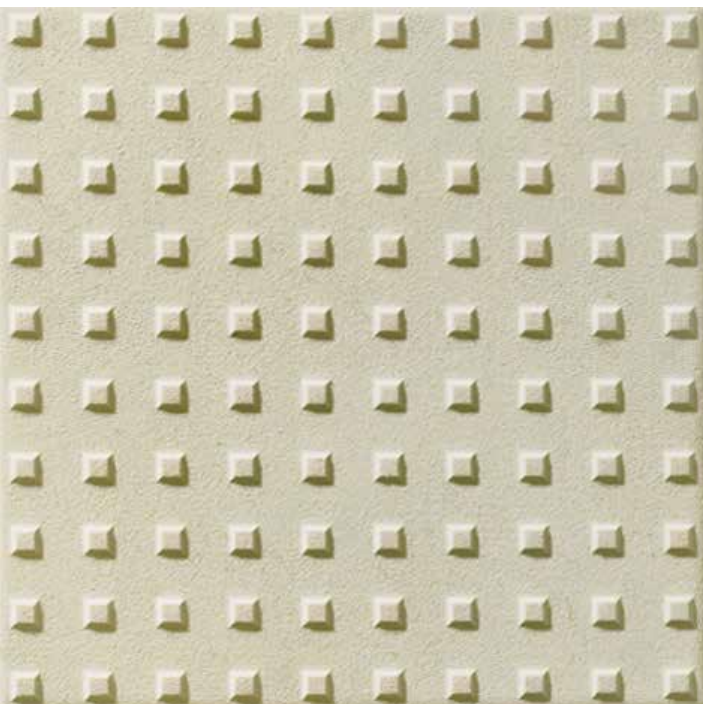

pavè R11 - V4 (A+B+C)







safe R13 (A+B+C)
agrèé par la CNAMTS



tundra satin,
bianco avorio secura
M 12,5 x 25 cm

FORMATI SIZES FORMATS FORMATE

GRES PORCELLANATO NON SMALTATO UNGLAZED PORCELAIN STONEWARE GRÉS CÉRAME NON ÉMAILLÉ UNGLASIERTE FEINSTEINZEUGFLIESEN

Formati Sizes Formats Formate	 cm 15x15 5 ⁷ / ₈ "x5 ⁷ / ₈ "	 cm 20x20 7 ⁷ / ₈ "x7 ⁷ / ₈ "	 cm 12,5x25[▲] 4 ⁷ / ₈ "x 9 ⁷ / ₈ "	 cm 30x30 11 ³ / ₄ "x11 ³ / ₄ "
Roccia	■	■	■	■
	8	8/12/14,2	8	8/11,2/14,2
Bugnato		■		
		8/12/14,2		
Profil	■	■	■	■
	8	8/12/14,2		
Pavè		■	■	
		8/12/14,2	8	
Secura	■	■	■	■
	8	8/12/14,2	8	8/11,2/14,2
Carbo		■		
		8,5/12*		
Technic	■	■	■	■
	8	8/12/14,2	8	8/11,2/14,2
Reticolo	■	■		
	8	8/12/14,2**		
Safe		■		
		8/12***		

▲ Dimensioni di fabbricazione 118x243. La modularità si ottiene con una fuga di 7mm.
Factory size 118x243. For modular laying, install with a 7 mm joint.
Dimensions de fabrication 118x243. Calpinage avec un joint de 7 mm.
Fertigungsgröße 118x243. Die Modularität wird mit einer 7 mm Füge erzielt.

* Produzione nei colori: Currently produced in the following colours:
Production dans les couleurs: Lieferbar in den Farben: **Bianco Avorio, Labrador.**

** Produzione nei colori: Currently produced in the following colours:
Production dans les couleurs: Lieferbar in den Farben: **Nebraska, Arkansas, Labrador.**

*** Produzione nei colori: Currently produced in the following colours:
Production dans les couleurs: Lieferbar in den Farben: **Bianco Avorio, Bianco B.**

Caratteristiche tecniche e imballi a pagina
Technical features and packing on page
Caractéristiques techniques et emballages à la page
Technische Eigenschaften und Verpackungen auf Seite

444

GRES PORCELLANATO SMALTATO GLAZED PORCELAIN STONEWARE GRÉS CÉRAME ÉMAILLÉ GLASIERTE FEINSTEINZEUGFLIESEN

Formati Sizes Formats Formate	 cm 12,5x12,5[▲] 4 ⁷ / ₈ "x 9 ⁷ / ₈ "
Satin	■ 8
Lucida	■ 8

PEZZI SPECIALI TRIMS ACCESSOIRES FORMSTÜCKE

Battiscopa Bullnose
Plinthe à bord arrondi Stehsockel
cm 9x30 - 3¹/₂"x11³/₄"
cm 10x20 - 4"x7⁷/₈"



Angolare Longitudinal angle
Angulaire Schenkelplatte
cm 20x5x5 - 7⁷/₈"x2"x2"

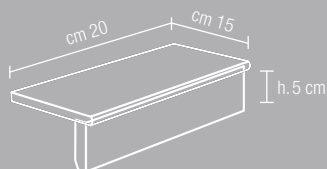

Sguscetta Cove
Gorge Rinneleiste
cm 4x20 - 1¹/₂"x7⁷/₈"



Gradino Step tread
Nez de marche Stufenplatte
cm 30x30 - 11³/₄"x11³/₄"

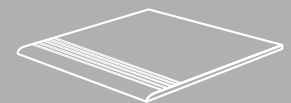

Zoccolo a raccordo a taglio retto
Cove base - straight top
Plinthe à gorge avec bord vif
Hohlkehlssockel (scharfkantig)
cm 10x20 - 4"x7⁷/₈"

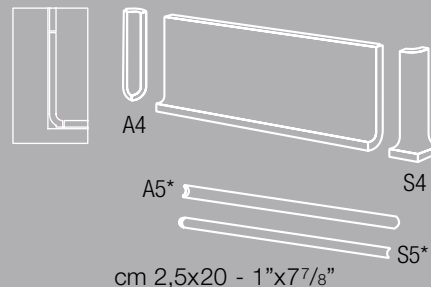

Zoccolo ad appoggio smussato
Sit-on skirting - bevelled top
Plinthe à talon avec bord arrondi
Aufsetzsockel mit abgerundeter Kante
cm 10x20 - 4"x7⁷/₈"

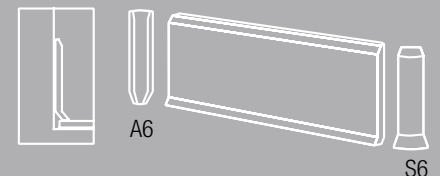

SPESSORI THICKNESSES ÉPAISSEURS STÄRKEN

technic
GRANITOGRES

8 mm

11,2/12 mm

14,2 mm

PEZZI SPECIALI MODULO M 12,5x25

MODULAR TRIMS ACCESSOIRES MODULAIRES MODULAR FORMSTÜCKE

SISTEMA CANALETTA 1 CHANNEL SYSTEM 1 SYSTEME CANIVEAU 1 RINNESYSTEM 1

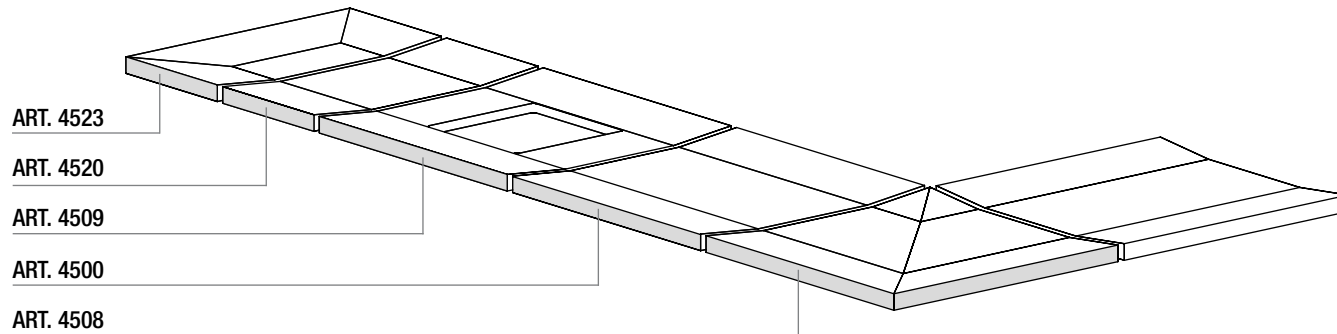

Produzione nei colori:
Currently produced in the following colours:
Production dans les couleurs :
Lieferbar in den Farben:
bianco avorio, bianco B
Superficie: Surface:
Surface : Oberfläche: **grip**

ART. 4523

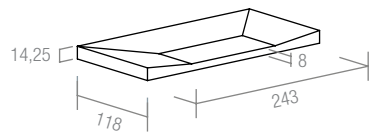

ART. 4520

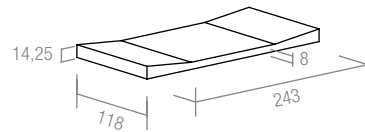

ART. 4509

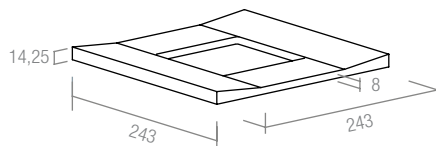

ART. 4500

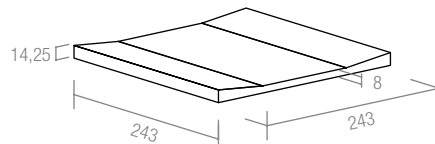

ART. 4508

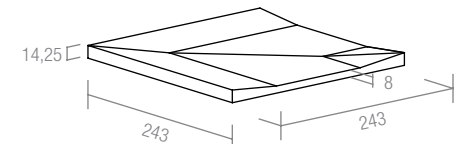

SISTEMA CANALETTA 2 CHANNEL SYSTEM 2 SYSTEME CANIVEAU 2 RINNESYSTEM 2

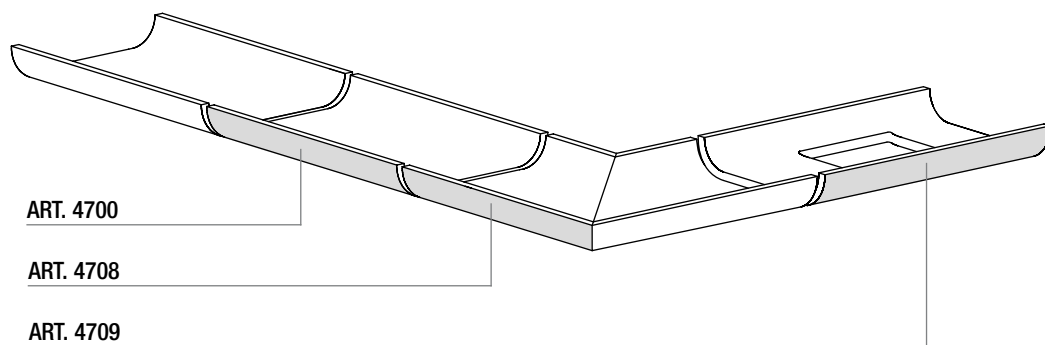

Produzione nei colori:
Currently produced in the following colours:
Production dans les couleurs :
Lieferbar in den Farben: **tundra 100**
Superficie: Surface:
Surface : Oberfläche: **satın**

ART. 4700

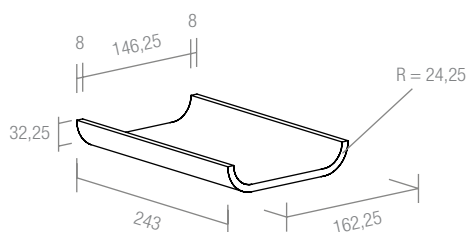

ART. 4708

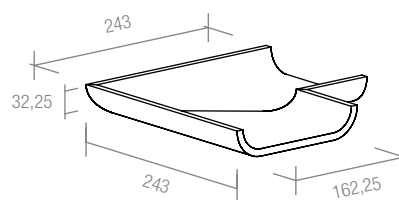

ART. 4709

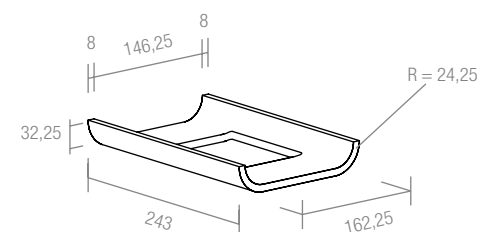

PEZZI SPECIALI MODULO M 12,5x25

MODULAR TRIMS ACCESSOIRES MODULAIRES MODULAR FORMSTÜCKE

technic
GRANITOGRES

SISTEMA BECCO DI CIVETTA BULLNOSE SYSTEM SYSTEME BORD ARRONDI STEH SOCKELSYSTEM

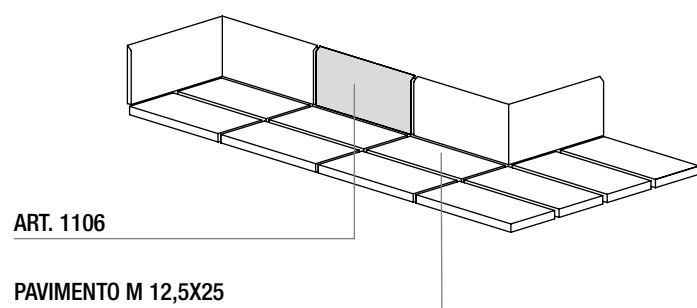

ART. 1106

PAVIMENTO M 12,5X25

Produzione nei colori: Currently produced in the following colours:
Production dans les couleurs : Lieferbar in den Farben:
bianco avorio, bianco B Superficie: Surface: Surface : Oberfläche: **matt**
tundra 100, beach 101 Superficie: Surface: Surface : Oberfläche: **satin**

ART. 1106

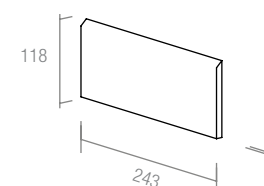

SISTEMA ZOCCOLO A RACCORDO SMUSSATO COVE BASE SYSTEM WITH BEVELLED TOP SYSTEME PLINTHE A GORGE BISEAUTE HÖHKEHL SOCKELSYSTEM MIT ABGERUNDETER KANTE

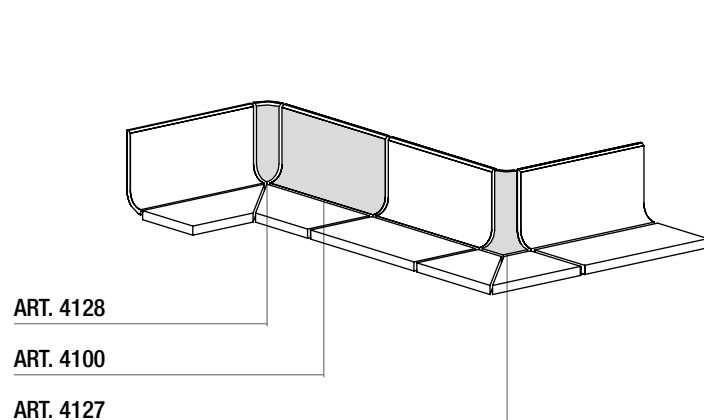

ART. 4128

ART. 4100

ART. 4127

Produzione nei colori: Currently produced in the following colours:
Production dans les couleurs : Lieferbar in den Farben:
bianco avorio, bianco B Superficie: Surface: Surface : Oberfläche: **matt**
tundra 100, beach 101 Superficie: Surface: Surface : Oberfläche: **satin**

ART. 4100

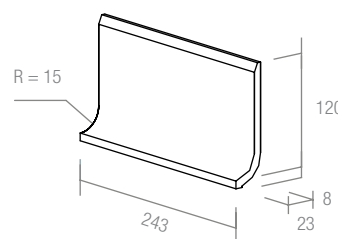

ART. 4127

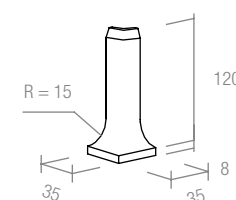

ART. 4128

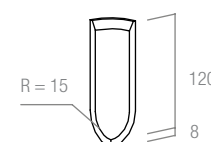

SISTEMA SGUSCETTA COVE SYSTEM SYSTEME GORGE RINNENLEISTESYSTEM

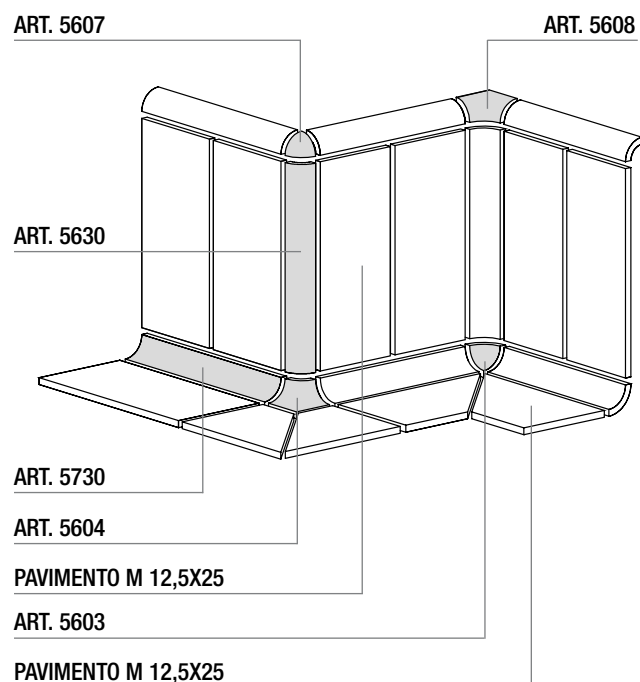

ART. 5607

ART. 5608

ART. 5630

ART. 5730

ART. 5604

PAVIMENTO M 12,5X25

ART. 5603

PAVIMENTO M 12,5X25

ART. 5607

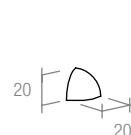

ART. 5603

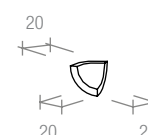

ART. 5630

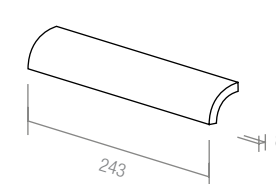

ART. 5604

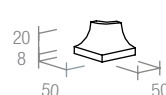

ART. 5608

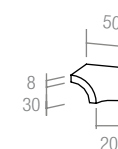

ART. 5730

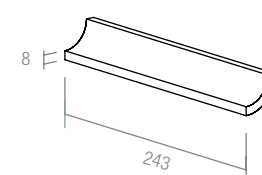

Produzione nei colori: Currently produced in the following colours:
Production dans les couleurs : Lieferbar in den Farben:
bianco avorio, bianco B Superficie: Surface: Surface : Oberfläche: **matt**
tundra 100 Superficie: Surface: Surface : Oberfläche: **satin, lucida**
beach 101 Superficie: Surface: Surface : Oberfläche: **satin**

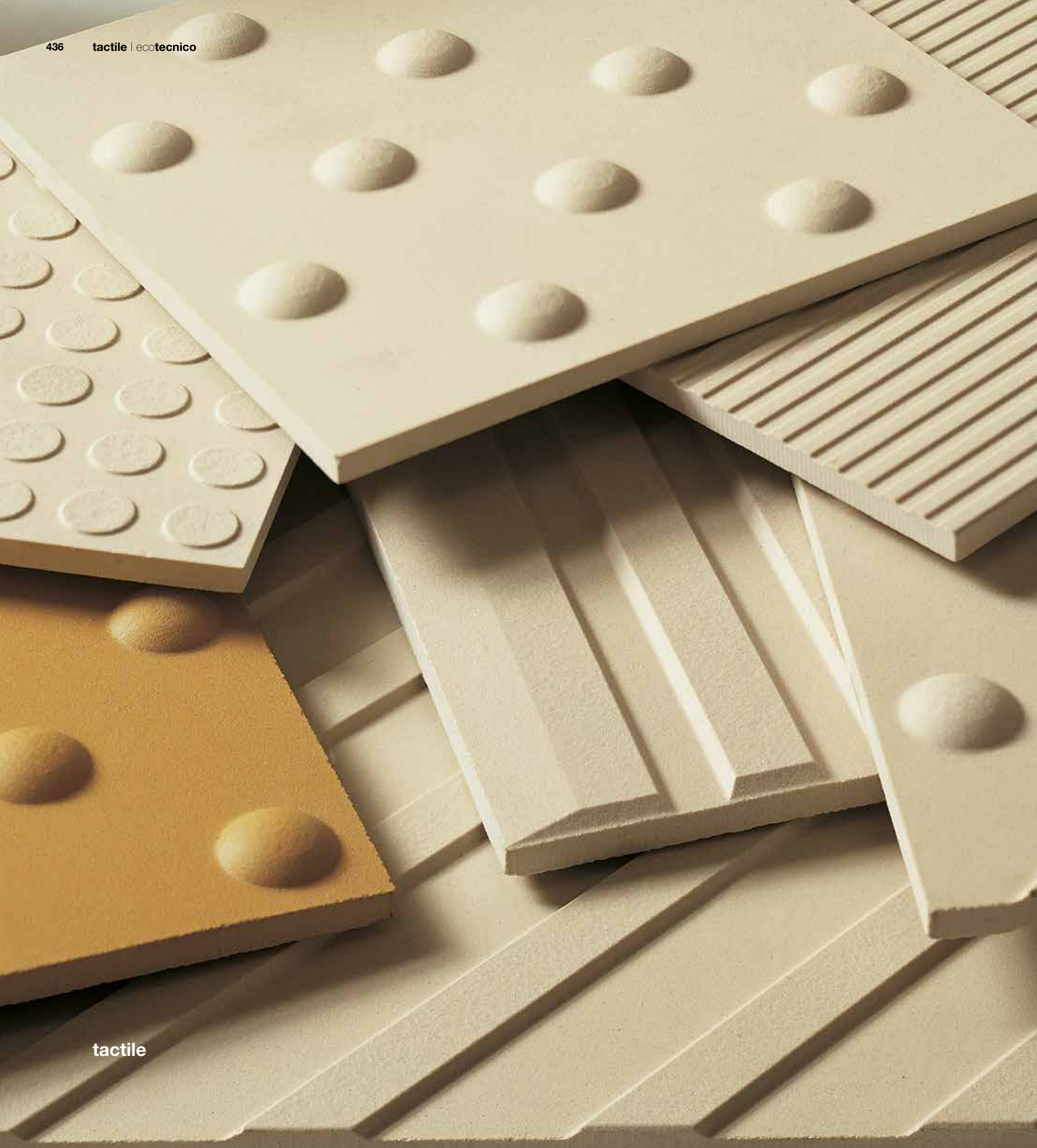

tactile
GRANITOGRES



tactile, ontario segura cm 30x30 - 11³/₄"x 11³/₄"

COLORI COLOURS COULEURS FARBEN*

budapest

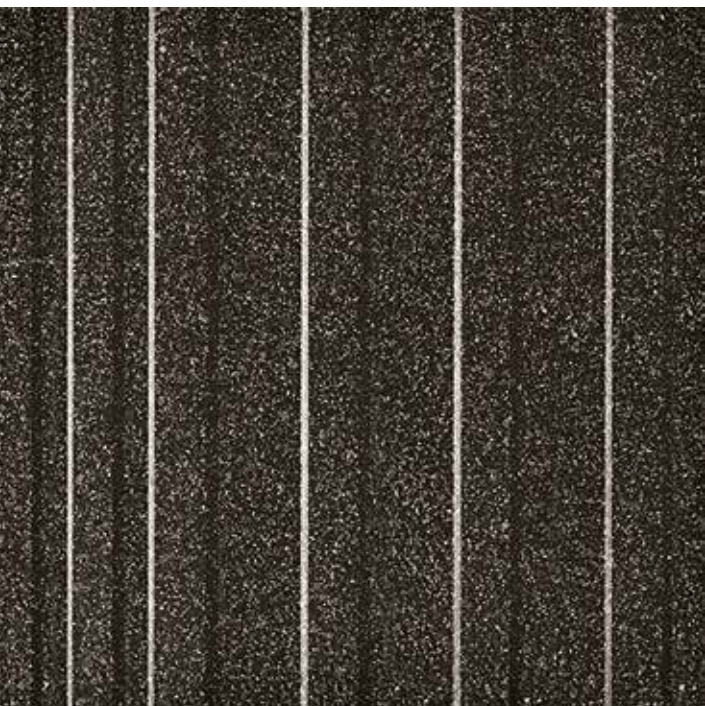

shanghai

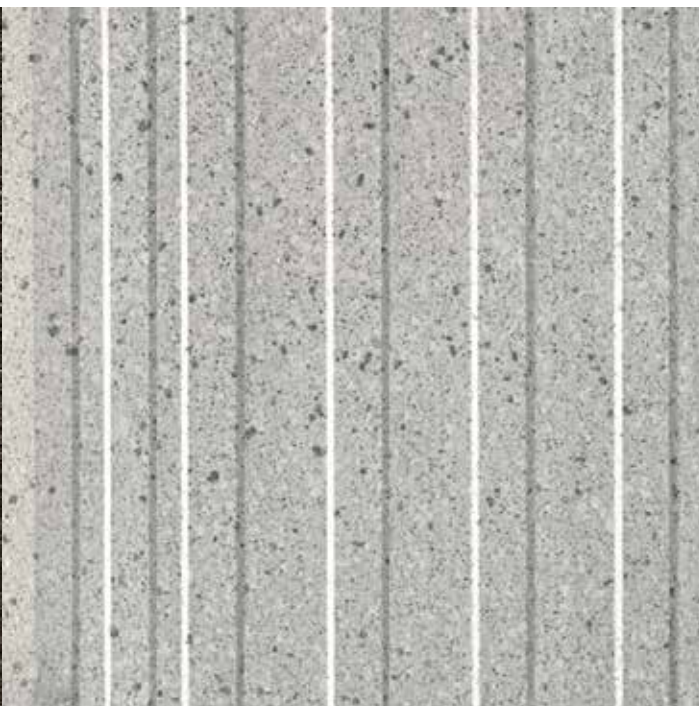

bianco avorio

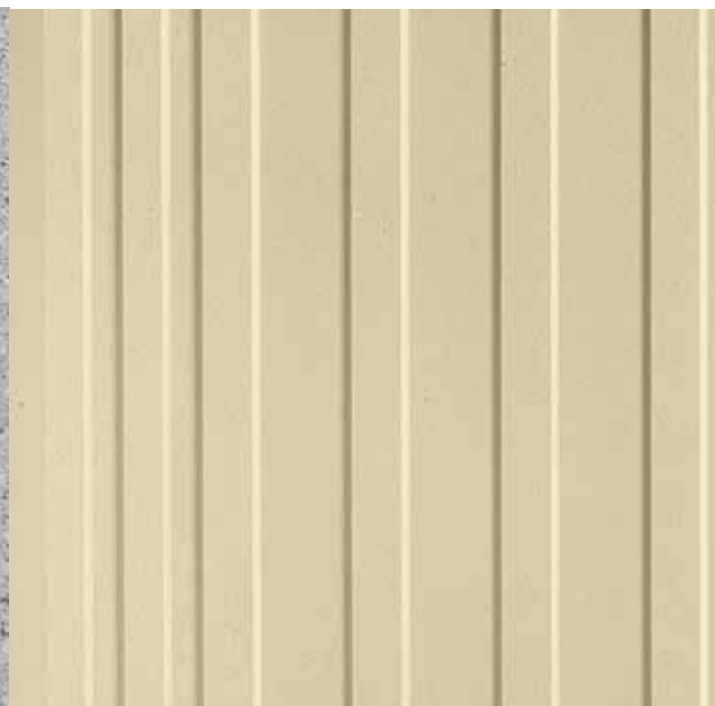

madrid



giallo ocra

* Eventuali altri colori possono essere richiesti dal progettista per particolari esigenze architettoniche o progettuali.
Other colours may be requested by the designer for specific architectural or design needs.
D'autres couleurs peuvent être éventuellement demandées par le projecteur pour exigences architecturales ou projectuelles.
Evt. andere Farben können von Architekt, im Fall Von besondere Baubedürfnisse, nachgefragt werden.

PERCORSO GUIDA PER DISABILI VISIVI
 GUIDED PATH FOR VISUALLY DISABLED PEOPLE
 PARCOURS GUIDE POUR LES MALVOYANT ET AVEUGLES
 SEHEBEHINDERTLEITWEG

tactile
 GRANITOGRES

Codice di direzione rettilinea
 Straight direction code
 Code de direction rectiligne
 Geradlinige Richtung



Codice di incrocio a T
 T-junction code
 Code de croisement en T
 T-förmige Kreuzung



Codice di svolta obbligata ad L
 Compulsory L-turn code
 Code de tournant obligatoire en L
 Obligatorisches L-förmiges Abbiegen

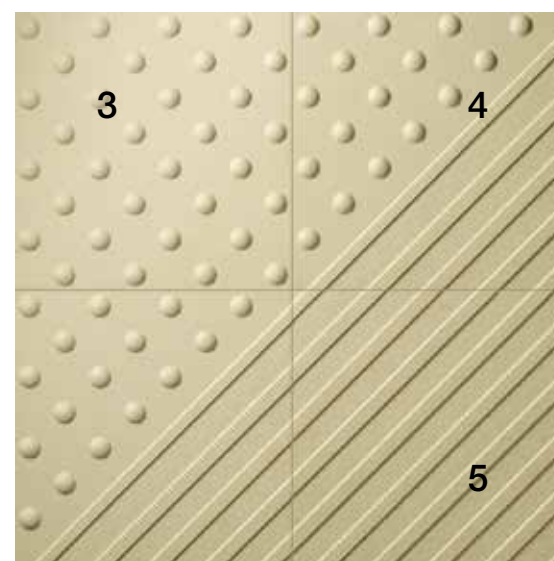

Codice di arresto-pericolo
 Stop-danger code
 Code d'arrêt-danger
 Stehenbleiben-Gefahr

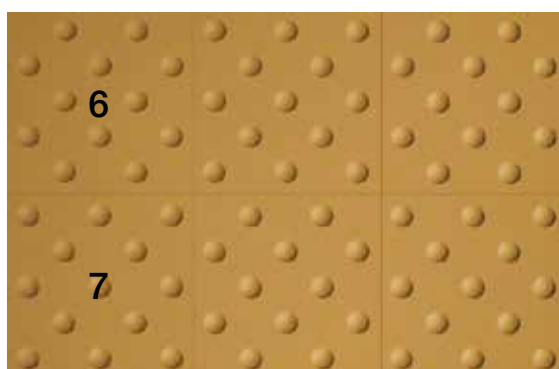

Codice di pericolo valicabile
 Dangerous to pass code
 Code de danger franchissable
 Überwindbare Gefahr

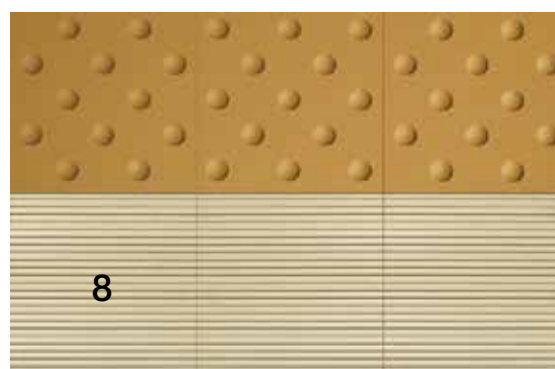

Codice di attenzione-servizio
 Attention-service code
 Code d'attention-service
 Achtung-Service

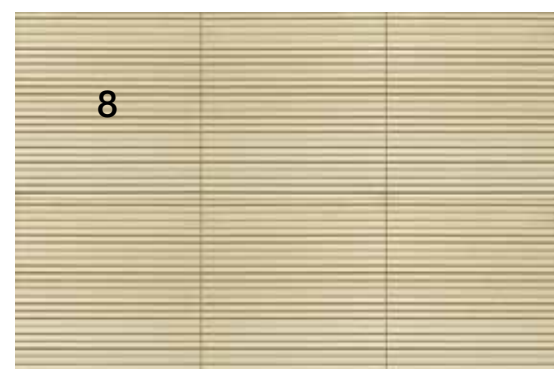

- 1. art. 30x30 rettilineo
- 2. art. 20x20 borchie
- 3. art. 30x30 tondi
- 4. art. 30x30 diagonale/tondi

- 5. art. 30x30 diagonale
- 6. art. 20x20 12 tondi
- 7. art. 20x20 13 tondi
- 8. art. 20x20 righe

e e e

utility

caratteristiche tecniche
technical features
caractéristiques techniques
technische Eigenschaften

444 **granitogres**

448 **pietre native**

450 **granitoker**

452 **gresplus**

454 **ecogres**

456 **stonalizzazione**
shade variations
variations d'ombre
farbtonvarianten

457 **complementi**
in acciaio e alluminio
accessories in steel
and aluminium
compléments en acier
et en aluminium
zusatzelemente
aus Stahl und Aluminium

458 **voci di capitolato**
specifications
cahier des charges
ausschreibungstexte

460 **posa e manutenzione**
installation and maintenance
pose et entretien
verlegung und Pflege

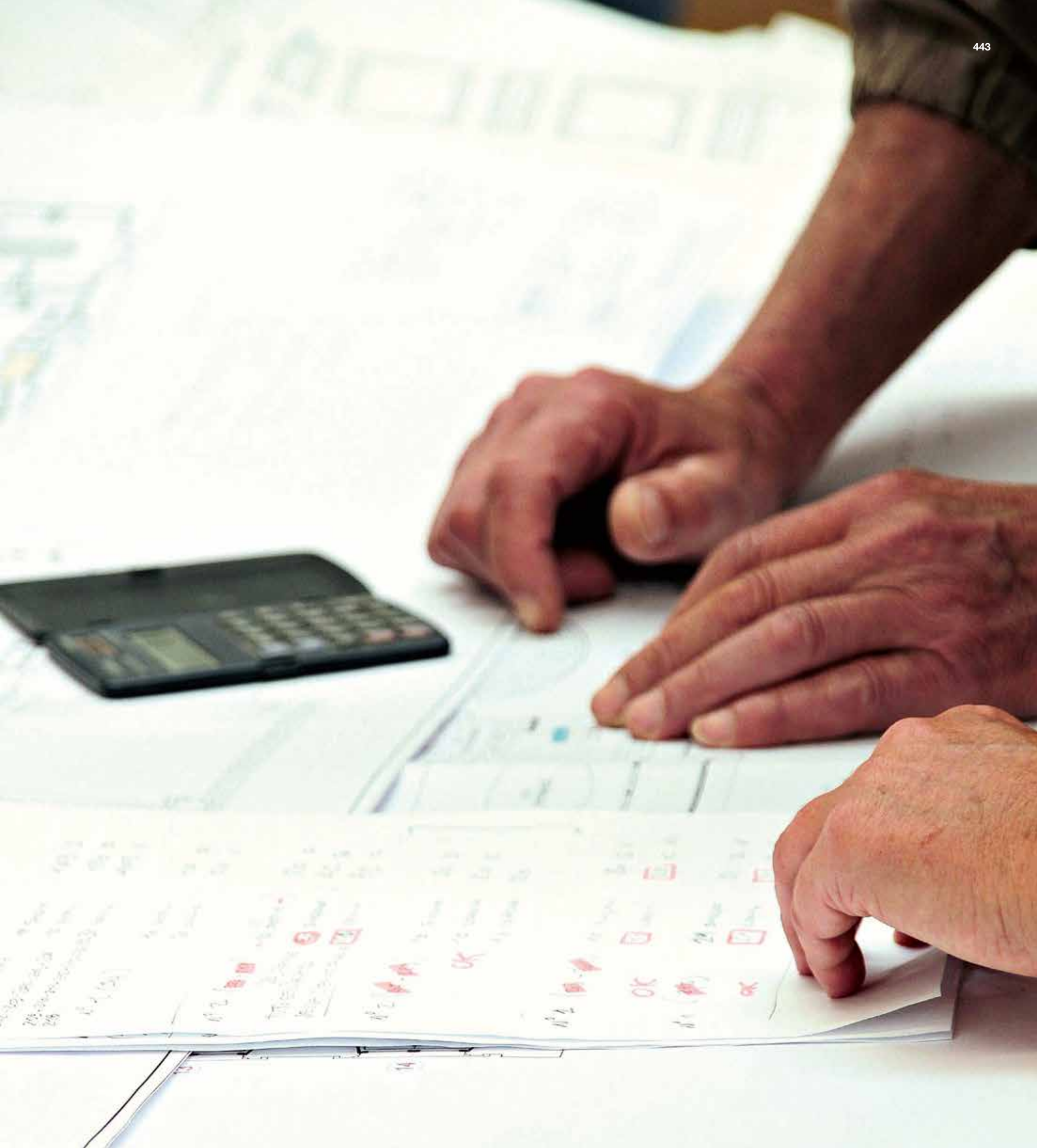









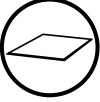

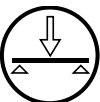
GRANITOGRES

CARATTERISTICHE TECNICHE TECHNICAL FEATURES
CARACTÉRISTIQUES TECHNIQUES TECHNISCHE EIGENSCHAFTEN



PT0050

	norma standards norme Norm	risultato prova* test results* resultats des essais* Ergebnisse*
 classificazione prodotto product classification classement Klassifizierung	UNI EN 14411-G ISO 13006	gruppo B1a UGL completamente greificato group B1a UGL fully vitrified group B1a UGL grès cérame fin Gruppe B1a UGL Feinsteinzeug
 caratteristiche dimensionali e d'aspetto dimensional and surface quality caractéristiques de la surface Oberflächenqualität	UNI EN ISO 10545-2	tolleranze minime nella 1 ^a scelta very low tolerance des tolérances minimales en 1er choix Entspricht Normen
 assorbimento di acqua water absorption absorption d'eau Wasseraufnahme	UNI EN ISO 10545-3	< 0,1%
 resistenza alla flessione flexural strenght résistance a la flexion Biegezug-Festigkeit	UNI EN ISO 10545-4	> 45 N/mm ²
 resistenza al gelo frost resistance résistance au gel Frostwiderstandsfähigkeit	qualsiasi norma all standards toute norme Alle normen	garantita guaranteed garantie Frostsicher
 resistenza attacco chimico (esclusione acido fluoridrico) resistance to acids and alkalis (with the exception of hydrofluoric acid) résistance à l'attaque chimique (exclusion de l'acide fluorhydrique) Säure und Laugen Beständigkeit (mit Ausnahme von Fluorwasserstoff)	UNI EN ISO 10545-13	nessuna alterazione no damage non attaquées Nicht angegriffen
 resistenza usura e abrasione wear and abrasion resistance résistance à l'usure et abrasion Abriebhärte	UNI EN ISO 10545-6	≤ 150 mm ³
 dilatazione termica lineare linear thermal expansion coefficient linéaire de dilatation thermique Lineare Wärmeausdehnung	UNI EN ISO 10545-8	6 x 10 ⁻⁶
 resistenza alle macchie stain resistance résistance aux taches Fleckenfestigkeit	UNI EN ISO 10545-14	garantita guaranteed garantie garantiert
 resistenza alla scivolosità (Superficie Naturale) slip resistance (Matt surface) résistance au glissement (Surface naturelle) Trittsicherheit (Natur Oberflächen)	DIN 51130 D.M. N° 236 del 14.06.89 Metodo B.C.R.	vedere singole serie see every series voir les séries une par une Siehe einzelne Serie valore μ > 0,40
 resistenza dei colori alla luce colour resistance to sunlight exposure résistance de la couleur à la lumière Unveränderlichkeit der Farben wenn Strahlung zugesetzt wird	DIN 51094	nessuna variazione no change of colours couleurs inchangées Keinerlei Farbänderung

* valore indicativo approx value donnee approximative Ungefähre Werte

**Test made on Granito 1, Arizona Matt

***Test made on Marte Series



norma ASTM
ASTM standards

risultato prova test results
resultats des essais Ergebnisse

ASTM C-373
impervious
≤ 0,5%

< 0,1%^{**}

ASTM C-648
breaking strength
≥ 250 lbs

425 lbs^{**}
625 lbs^{***}

ASTM C-1026
no sample must show
alterations to surface

resistant

ASTM C-650
alterations to surface

ASTM C-501
≥ 100

311^{**}











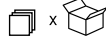

ASTM C-1028
NO ANSI
Standard

≥ 0,6 in matt surface^{**}
≥ 0,7 in matt and bocciardato surfaces^{***}

▲ Si rimanda all'elenco prodotti UPEC ufficiale, consultabile sul sito: Please see the official UPEC product list:
Veuillez consulter la liste officielle produits UPEC: Sïhe die offizielle UPEC-Produktliste auf der Website: <http://webapp.cstb.fr/upec-ceramique/>

GRANITOGRES

PESI, MISURE E CONTENUTO DEI COLLI WEIGHT, SIZE AND CONTENTS OF THE PACKING POIDS, DIMENSIONS, CONTENU DES COLIS VERPACKUNGSGRÖSSEN/GEWICHTE

		mm ▼ ▲	 x 	 x 	 x 	 x 	 x 	 x 
cm 10x20	4"x7 ⁷ / ₈ "	8	60	1,20	18,0	68	81,60	1.469
cm 10x60	4"x23 ⁵ / ₈ "	9,4	18	1,08	21,6	48	51,84	1.120
cm 12,5x25	4 ⁷ / ₈ "x9 ⁷ / ₈ "	8	32	1,00	18,0	72	72,00	1.296
cm 15x15	5 ⁷ / ₈ "x5 ⁷ / ₈ "	8	44	0,99	17,0	64	63,36	1.077
cm 15x15	5 ⁷ / ₈ "x5 ⁷ / ₈ " Pietre Runiche	9	38	0,86	21,0	64	54,72	1.149
cm 15x15	5 ⁷ / ₈ "x5 ⁷ / ₈ " Natural Slate	9	40	0,90	21,0	64	57,60	1.210
cm 15x30	5 ⁷ / ₈ "x11 ³ / ₄ "	8	22	0,99	18,0	64	63,36	1.140
cm 15x30	5 ⁷ / ₈ "x11 ³ / ₄ " Pietre Runiche	9	19	0,85	21,0	64	54,40	1.142
cm 15x30	5 ⁷ / ₈ "x11 ³ / ₄ " Pietre Runiche	9	20	0,90	21,0	64	57,60	1.210
cm 15x60	5 ⁷ / ₈ "x23 ⁵ / ₈ "	9,4	12	1,08	21,6	40	43,20	933
cm 15x90	5 ⁷ / ₈ "x35 ³ / ₈ "	10,5	6	0,81	25,0	48	38,88	972
cm 20x20	7 ⁷ / ₈ "x7 ⁷ / ₈ "	8	30	1,20	18,0	68	81,60	1.469
cm 20x20	7 ⁷ / ₈ "x7 ⁷ / ₈ "	12	21	0,84	27,0	68	57,12	1.542
cm 20x20	7 ⁷ / ₈ "x7 ⁷ / ₈ "	14,2	18	0,72	32,0	51	36,72	1.175
cm 20x60	7 ⁷ / ₈ "x23 ⁵ / ₈ "	10,5	8	0,96	25,0	48	46,08	1.152
cm 20x120	7 ⁷ / ₈ "x47 ¹ / ₄ "	10,5	4	0,96	25,0	42	40,32	1.008
cm 30x30	11 ³ / ₄ "x11 ³ / ₄ "	7,6	14	1,26	17,5	48	60,48	1.058
cm 30x30	11 ³ / ₄ "x11 ³ / ₄ " levigata polished	8	14	1,26	17,0	48	60,48	1.028
cm 30x30	11 ³ / ₄ "x11 ³ / ₄ "	8	13	1,17	18,0	48	56,16	1.011
cm 30x30	11 ³ / ₄ "x11 ³ / ₄ "	8,2	13	1,17	19,0	48	56,16	1.067
cm 30x30	11 ³ / ₄ "x11 ³ / ₄ "	8,5	13	1,17	19,0	48	56,16	1.067
cm 30x30	11 ³ / ₄ "x11 ³ / ₄ " Pietre Runiche	9	11	0,99	21,0	48	47,52	998
cm 30x30	11 ³ / ₄ "x11 ³ / ₄ " Natural Slate	9	12	1,08	21,0	48	51,84	1.089
cm 30x30	11 ³ / ₄ "x11 ³ / ₄ " non rettificato unrectified	9	12	1,08	21,0	48	51,84	1.089
cm 30x30	11 ³ / ₄ "x11 ³ / ₄ " levigata polished	9,4	13	1,17	20,0	48	56,16	1.123
cm 30x30	11 ³ / ₄ "x11 ³ / ₄ "	9,4	12	1,08	21,6	48	51,84	1.120
cm 30x30	11 ³ / ₄ "x11 ³ / ₄ "	10	11	0,99	23,0	48	47,52	1.093
cm 30x30	11 ³ / ₄ "x11 ³ / ₄ " levigata polished	10,5	11	0,99	23,0	48	47,52	1.093
cm 30x30	11 ³ / ₄ "x11 ³ / ₄ "	11,2	10	0,9	26,0	48	43,20	1.123
cm 30x30	11 ³ / ₄ "x11 ³ / ₄ "	14,2	8	0,72	32,7	48	34,56	1.130
cm 30x60	11 ³ / ₄ "x23 ⁵ / ₈ "	9	6	1,08	21,0	48	51,84	1.089
cm 30x60	11 ³ / ₄ "x23 ⁵ / ₈ " levigata polished	9,4	6	1,08	20,0	48	51,84	1.037
cm 30x60	11 ³ / ₄ "x23 ⁵ / ₈ "	9,4	6	1,08	21,6	48	51,84	1.120
cm 30x60	11 ³ / ₄ "x23 ⁵ / ₈ " levigata polished	10	5	0,90	23,0	48	43,20	994
cm 30x60	11 ³ / ₄ "x23 ⁵ / ₈ "	10	5	0,90	24,0	48	43,20	1.037
cm 30x60	11 ³ / ₄ "x23 ⁵ / ₈ "	10,5	5	0,90	25,0	48	43,20	1.080
cm 40x40	15 ³ / ₄ "x15 ³ / ₄ "	9	8	1,28	21,0	48	61,44	1.290
cm 40x40	15 ³ / ₄ "x15 ³ / ₄ " levigata polished	9,4	8	1,28	19,0	48	61,44	1.167
cm 40x40	15 ³ / ₄ "x15 ³ / ₄ "	9,4	8	1,28	21,6	48	61,44	1.327
cm 40x40	15 ³ / ₄ "x15 ³ / ₄ "	14,2	5	0,80	32,0	48	38,40	1.229
cm 45x45	17 ³ / ₄ "x17 ³ / ₄ "	9	5	1,01	21,6	34	34,41	743
cm 45x90	17 ³ / ₄ "x35 ³ / ₈ "	10,5	3	1,22	25,0	30	36,45	911
cm 60x60	23 ⁵ / ₈ "x23 ⁵ / ₈ "	10	4	1,44	24,0	30	43,20	1.037
cm 60x60	23 ⁵ / ₈ "x23 ⁵ / ₈ "	10,5	4	1,44	25,0	30	43,20	1.080
cm 60x120	23 ⁵ / ₈ "x47 ¹ / ₄ " levigata polished	10,5	2	1,44	23,0	24	34,56	795
cm 60x120	23 ⁵ / ₈ "x47 ¹ / ₄ "	10,5	2	1,44	25,0	24	34,56	864
cm 90x90	35 ³ / ₈ "x35 ³ / ₈ "	10,5	2	1,62	25,0	24	38,88	972

**PESI, MISURE E CONTENUTO DEI COLLI WEIGHT, SIZE AND CONTENTS OF THE PACKING
POIDS, DIMENSIONS, CONTENU DES COLIS VERPACKUNGSGRÖSSEN/GEWICHTE**

BATTISCOPA B.C. BULLNOSE PLINTHE À BORD ARRONDI STEHSOCKEL			
cm 9x30	3½"x11¾"	<i>Agorà - Ardesia - Granito 1 - Granito 1Evo Granito 2 - Granito 3 - Tiburtino - Unicolore</i>	30
cm 9x30	3½"x11¾"	<i>Marmogres - Marte Natural Slate - Pietre Rare - Titano</i>	28
cm 9x30	3½"x11¾"	<i>Pietre Runiche</i>	27
cm 9x40	3½"x15¾"		22
cm 9x45	3½"x17¾"		18
cm 9x60	3½"x23⅝"		18
cm 9x90	3½"x35⅝"		9
cm 10x20	4"x7⅞"		30
GRADINO STEP TREAD NEZ DE MARCHE STUFENPLATTE			
cm 30x30	11¾"x11¾"		13
cm 30x30	11¾"x11¾"	<i>levigata polished</i>	14
cm 30x30	11¾"x11¾"	<i>Marte - Natural Slate Pietre Rare - Titano</i>	12
cm 30x30	11¾"x11¾"	<i>levigata polished Marte - Pietre Rare - Titano</i>	13
cm 30x30	11¾"x11¾"	<i>Marmogres - Pietre Runiche</i>	11
cm 30x60	11¾"x23⅝"	<i>Marte - Pietre Rare - Titano</i>	6
cm 30x60	11¾"x23⅝"	<i>Marmogres</i>	5
cm 40x40	15¾"x15¾"		8
cm 45x45	17¾"x17¾"		5
SCALINO			
cm 40x33	16"x13"		4
cm 45x33	18"x13"		4
cm 60x33	23⅝"x13"	<i>Marmogres</i>	6
SCALINO ANGOLARE			
cm 40x33	16"x13"		3
cm 45x33	18"x13"		3
cm 60x33	23⅝"x13"	<i>Marmogres</i>	4
GRADONE			
cm 25x33	10"x13"		5
cm 30x33	11¾"x13"		4
cm 60x33	23⅝"x13"		4
GRADONE ANGOLARE			
cm 25x33	10"x13"		5
cm 30x33	11¾"x13"		2
cm 60x33	23⅝"x13"		3









GRADONE RUSTICATO			
cm 30x30	11¾"x11¾"		4
GRADONE ANGOLARE RUSTICATO			
cm 30x30	11¾"x11¾"		2
GRADONE TORO			
cm 60x33	23⅝"x13"		4
cm 60x33	23⅝"x13"		1
<i>Con bordo antiscivolo. Step treadstep with non-slip edging. Marche avec nez antidérapant. Stufenplatte mit rutschsicherer Kante.</i>			
cm 120x33	47¼"x13"		4
ANGOLARE TORO			
cm 60x33	23⅝"x13"		4
cm 120x33	47¼"x13"		2
ZOCCOLO SKIRTING PLINTHE HOHLKEHLSOCKEL			
cm 10x20	4"x7⅞"		30
cm 10x30	4"x11¾"		30
cm 15x30	5⅞"x11¾"		12
SGUSCETTA COVE GORGE RINNLEISTE			
cm 4x20	1½"x7⅞"		30
cm 2,5x10	1"x4"	A4 - S4	10
cm 2,5x20	1"x7⅞"	A5 - S5	60
cm 3x15	1"x5⅞"	A7 - S7	10
TOZZETTO INSERT CABOCHON EINLEGER			
cm 9x9	3½"x3½"		35
cm 9x9	3½"x3½"	<i>Marmogres - Marte - Pietre Rare - Titano</i>	33
LISTELLO LISTEL LISTEL ZEIERLEISTE			
cm 9x30	3½"x11¾"		30
cm 9x30	3½"x11¾"	<i>Marmogres - Marte - Pietre Rare - Titano</i>	28
cm 9x40	3½"x16"		22
cm 9x60	3½"x23⅝"		18
TERMINALE STEP TREAD REBORD BECKENRANDPLATTE			
cm 15x30x3,5	6"x11¾"x1½"		6
cm 15x30x5	6"x11¾"x2"		8
cm 30x30x5	11¾"x11¾"x2"		4

PIETRE NATIVE

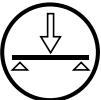
CARATTERISTICHE TECNICHE TECHNICAL FEATURES
CARACTÉRISTIQUES TECHNIQUES TECHNISCHE EIGENSCHAFTEN





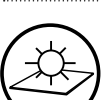







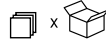

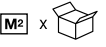
PT0050

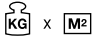

	norma standards norme Norm	risultato prova* test results* resultats des essais* Ergebnisse*
 classificazione prodotto product classification classement Klassifizierung	UNI EN 14411-G ISO 13006	gruppo B1a completamente greificato group B1a fully vitrified group B1a grès cérame fin Gruppe B1a Feinsteinzeug
 caratteristiche dimensionali e d'aspetto dimensional and surface quality caractéristiques de la surface Oberflächenqualität	UNI EN ISO 10545-2	tolleranze minime nella 1ª scelta very low tolerance des tolérances minimales en 1er choix Entspricht Normen
 assorbimento di acqua water absorption absorption d'eau Wasseraufnahme	UNI EN ISO 10545-3	< 0,1%
 resistenza alla flessione flexural strenght résistance a la flexion Biegezug-Festigkeit	UNI EN ISO 10545-4	> 45 N/mm ²
 resistenza al gelo frost resistance résistance au gel Frostwiderstandsfähigkeit	qualsiasi norma all standards toute norme Alle normen	garantita guaranteed garantie Frostsicher
 resistenza attacco chimico (esclusione acido fluoridrico) resistance to acids and alkalis (with the exception of hydrofluoric acid) résistance à l'attaque chimique (exclusion de l'acide fluorhydrique) Säure und Laugen Beständigkeit (mit Ausnahme von Fluorwasserstoff)	UNI EN ISO 10545-13	nessuna alterazione no damage non attaquées nicht angegriffen
 resistenza usura e abrasione wear and abrasion resistance résistance à l'usure et abrasion Abriebhärte	UNI EN ISO 10545-6	≤150 mm ³
 dilatazione termica lineare linear thermal expansion coefficient linéaire de dilatation thermique Lineare Wärmeausdehnung	UNI EN ISO 10545-8	6 x 10 ⁻⁶
 resistenza alle macchie stain resistance résistance aux taches Fleckenfestigkeit	UNI EN ISO 10545-14	garantita guaranteed garantie garantiert
 resistenza alla scivolosità (Superficie Naturale) slip resistance (Matt surface) résistance au glissement (Surface naturelle) Trittsicherheit (Natur Oberflächen)	DIN 51130	vedere singole serie see every series voir les séries une par une Seihe einzelne Serie
	D.M. N° 236 del 14.06.89 Metodo B.C.R	valore μ > 0,40
 resistenza dei colori alla luce colour resistance to sunlight exposure résistance de la couleur à la lumière Unveränderlichkeit der Farben wenn Strahlung zugesetzt wird	DIN 51094	nessuna variazione no change of colours couleurs inchangées Keinerlei Farbänderung

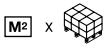

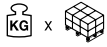
* valore indicativo approx value
donnee approximative Ungefährte Werte

▲ Si rimanda all'elenco prodotti UPEC ufficiale, consultabile sul sito: Please see the official UPEC product list:
Veuillez consulter la liste officielle produits UPEC: Sihe die offizielle UPEC-Produktliste auf der Website: <http://webapp.cstb.fr/upec-ceramique/>

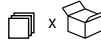
Al pari delle pietre naturali, le sfumature e le venature delle piastrelle della linea Pietre Native, non sono ripetitive. As whit natural stones, the shades and vein patterns of the tiles in the Pietre Native line are not repetitive. Tout comme sur les pierres naturelles, les nuances et les veines des carreaux de la ligne Pietre Native ne sont pas répétitives. Genauso wie bei den Natursteinen sind die Farbabschattungen und Äderungen der Fliesen der Produktlinie Pietre Native nicht repetitiv.

			mm ▼ ▲	 x 	 x 	 x 	 x 	 x 	 x 
cm 15x15	5 ⁷ / ₈ "x5 ⁷ / ₈ "	non rettificato unrectified	8,3	44	0,99	18,0	64	63,36	1.140
cm 15x15	5 ⁷ / ₈ "x5 ⁷ / ₈ "		9,4	40	0,90	21,6	64	57,60	1.244
cm 15x30	5 ⁷ / ₈ "x11 ³ / ₄ "	non rettificato unrectified	8,3	22	0,99	18,0	64	63,36	1.140
cm 15x60	5 ⁷ / ₈ "x23 ⁵ / ₈ "		9,4	12	1,08	21,6	40	43,20	933
cm 30x30	11 ³ / ₄ "x11 ³ / ₄ "		8,2	13	1,17	19,0	48	56,16	1.067
cm 30x30	11 ³ / ₄ "x11 ³ / ₄ "		9,4	12	1,08	21,6	48	51,84	1.120
cm 30x60	11 ³ / ₄ "x23 ⁵ / ₈ "		9	6	1,08	21,0	48	51,84	1.089
cm 30x60	11 ³ / ₄ "x23 ⁵ / ₈ "		9,4	6	1,08	21,6	48	51,84	1.120
cm 30x60	11 ³ / ₄ "x23 ⁵ / ₈ "		10	5	0,90	24,0	48	43,20	1.037
cm 30x60	11 ³ / ₄ "x23 ⁵ / ₈ "		10,5	5	0,90	25,0	48	43,20	1.080
cm 37,5x75,5	14 ¹ / ₂ "x3"		10	4	1,12	24	48	53,76	1.290
cm 45x45	17 ³ / ₄ "x17 ³ / ₄ "		4,9	10	2,03	11,3	34	68,85	778
cm 45x45	17 ³ / ₄ "x17 ³ / ₄ "		9	5	1,01	21,6	34	34,41	743
cm 45x45	17 ³ / ₄ "x17 ³ / ₄ "		10,5	5	1,01	25,0	34	34,41	860
cm 45x90	17 ³ / ₄ "x35 ³ / ₈ "		4,9	6	2,43	11,3	30	72,90	824
cm 45x90	17 ³ / ₄ "x35 ³ / ₈ "		10	3	1,22	24,0	30	36,60	878
cm 45x90	17 ³ / ₄ "x35 ³ / ₈ "		10,5	3	1,22	25,0	30	36,45	911
cm 45x90	17 ³ / ₄ "x35 ³ / ₈ "		20	2	0,81	44,5	26	21,06	937
cm 60x60	23 ⁵ / ₈ "x23 ⁵ / ₈ "		4,9	8	2,88	11,3	30	86,40	976
cm 60x60	23 ⁵ / ₈ "x23 ⁵ / ₈ "		10	4	1,44	24,0	30	43,20	1.037
cm 60x60	23 ⁵ / ₈ "x23 ⁵ / ₈ "		10,5	4	1,44	25	30	43,20	1.080
cm 60x60	23 ⁵ / ₈ "x23 ⁵ / ₈ "		20	2	0,72	46	32	23,04	1.060
cm 60x120	23 ⁵ / ₈ "x47 ¹ / ₄ "		4,9	4	2,88	11,3	24	69,12	781
cm 60x120	23 ⁵ / ₈ "x47 ¹ / ₄ "		10	2	1,44	24,0	24	34,56	829
cm 60x120	23 ⁵ / ₈ "x47 ¹ / ₄ "		10,5	2	1,44	25,0	24	34,56	864
cm 75,5x75,5	29 ³ / ₄ "x29 ³ / ₄ "		10	2	1,14	24,0	45	51,30	1.231
cm 90x90	35 ³ / ₈ "x35 ³ / ₈ "		10	2	1,62	24,0	24	38,88	933
cm 90x90	35 ³ / ₈ "x35 ³ / ₈ "		10,5	2	1,62	25,0	24	38,88	972
cm 90x180	35 ³ / ₈ "x70 ⁷ / ₈ "		10	1	1,62	24,0	30	48,60	1.166

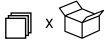







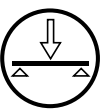

		 x 
BATTISCOPA B.C. BULLNOSE PLINTHE À BORD ARRONDI STEHSOCKEL		
cm 9x30	3 ¹ / ₂ "x11 ³ / ₄ "	28
cm 9x40	3 ¹ / ₂ "x16"	22
cm 9x45	3 ¹ / ₂ "x18"	18
cm 9x60	3 ¹ / ₂ "x23 ⁵ / ₈ "	18
cm 9x75,5	3 ¹ / ₂ "x29 ³ / ₄ "	8
cm 9x90	3 ¹ / ₂ "x35 ³ / ₈ "	9
GRADINO STEP TREAD NEZ DE MARCHE STUFENPLATTE		
cm 30x30	11 ³ / ₄ "x11 ³ / ₄ "	12
cm 30x60	11 ³ / ₄ "x23 ⁵ / ₈ "	6
cm 40x40	15 ³ / ₄ "x15 ³ / ₄ "	8
cm 45x45	17 ³ / ₄ "x17 ³ / ₄ "	5
SCALINO		
cm 30x33	11 ³ / ₄ "x13"	6
SCALINO ANGOLARE		
cm 30x33	11 ³ / ₄ "x13"	4
GRADONE		
cm 30x33	11 ³ / ₄ "x13"	4
cm 33x33	13"x13"	4
cm 60x33	23 ⁵ / ₈ "x13"	4

		 x 
ANGOLARE		
cm 30x33	11 ³ / ₄ "x13"	2
cm 33x33	13"x13"	2
cm 60x33	23 ⁵ / ₈ "x13"	3
GRADONE ASSEMBLATO		
cm 60x33	23 ⁵ / ₈ "x13"	4
cm 120x33	47 ¹ / ₄ "x13"	2
ANGOLARE ASSEMBLATO		
cm 60x33	23 ⁵ / ₈ "x13"	3
cm 120x33	47 ¹ / ₄ "x13"	1
TOZZETTO INSERT CABOCHON EINLEGER		
cm 9x9	3 ¹ / ₂ "x3 ¹ / ₂ "	33
LISTELLO LISTEL LISTEL ZEIERLEISTE		
cm 9x30	3 ¹ / ₂ "x11 ³ / ₄ "	28
cm 9x40	3 ¹ / ₂ "x15 ³ / ₄ "	22
cm 9x45	3 ¹ / ₂ "x17 ³ / ₄ "	18
TERMINALE STEP TREAD REBORD BECHKENRANDPLATTE		
cm 15x30x3,5	6"x11 ³ / ₄ "x3 ³ / ₈ "	6
cm 15x30x5	5 ⁷ / ₈ "x11 ³ / ₄ "x2"	8

GRANITOKER

CARATTERISTICHE TECNICHE TECHNICAL FEATURES
CARACTÉRISTIQUES TECHNIQUES TECHNISCHE EIGENSCHAFTEN





	norma standards norme Norm	risultato prova* test results* resultats des essais* Ergebnisse*
 classificazione prodotto product classification classement Klassifizierung	UNI EN 14411-G ISO 13006	gruppo Bla GL completamente greificato group Bla GL fully vitrified group Bla GL grès cérame fin Gruppe Bla GL Feinsteinzeug
 caratteristiche dimensionali e d'aspetto dimensional and surface quality caractéristiques de la surface Oberflächenqualität	UNI EN ISO 10545-2	tolleranze minime nella 1ª scelta very low tolerance des tolérances minimales en 1er choix Entspricht Normen
 assorbimento di acqua water absorption absorption d'eau Wasseraufnahme	UNI EN ISO 10545-3	< 0,1%
 resistenza alla flessione flexural strenght résistance a la flexion Biegezug-Festigkeit	UNI EN ISO 10545-4	> 45 N/mm ²
 resistenza al gelo frost resistance résistance au gel Frostwiderstandsfähigkeit	qualsiasi norma all standards toute norme Alle normen	garantita guaranteed garantie Frostsicher
 resistenza attacco chimico (esclusione acido fluoridrico) resistance to acids and alkalis (with the exception of hydrofluoric acid) résistance à l'attaque chimique (exclusion de l'acide fluorhydrique) Säure und Laugen Beständigkeit (mit Ausnahme von Fluorwasserstoff)	UNI EN ISO 10545-13	Nessuna alterazione No damage Non attaquées Nicht angegriffen
 resistenza usura e abrasione wear and abrasion resistance résistance à l'usure et abrasion Abriebhärte	UNI EN ISO 10545-7	Alta High Haute Hoch
 dilatazione termica lineare linear thermal expansion coefficient linéaire de dilatation thermique Lineare Wärmeausdehnung	UNI EN ISO 10545-8	6 x 10 ⁻⁶
 resistenza alle macchie stain resistance résistance aux taches Fleckenfestigkeit	UNI EN ISO 10545-14	garantita guaranteed garantie garantiert
 resistenza alla scivolosità (Superficie Naturale) slip resistance (Matt surface) résistance au glissement (Surface naturelle) Trittsicherheit (Natur Oberflächen)	DIN 51130 D.M. N° 236 del 14.06.89 Metodo B.C.R	vedere singole serie see every series voir les séries une par une Seihe einzelne Serie
 resistenza dei colori alla luce colour resistance to sunlight exposure résistance de la couleur à la lumière Unveränderlichkeit der Farben wenn Strahlung zugesetzt wird	DIN 51094	nessuna variazione no change of colours couleurs inchangées Keinerlei Farbänderung

▲ Si rimanda all'elenco prodotti UPEC ufficiale, consultabile sul sito: Please see the official UPEC product list:
Veuillez consulter la liste officielle produits UPEC: Sihe die offizielle UPEC-Produktliste auf der Website: <http://webapp.cstb.fr/upec-ceramique/>

* valore indicativo approx value
donnee approximative Ungefährhe Werte

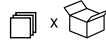
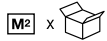
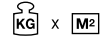
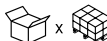
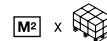
PESI, MISURE E CONTENUTO DEI COLLI WEIGHT, SIZE AND CONTENTS OF THE PACKING
POIDS, DIMENSIONS, CONTENU DES COLIS VERPACKUNGSGRÖSSEN/GEWICHTE

			mm						
			mm						
cm 9,8x59	37/8"x231/4"	non rettificato unrectified	10	18	1,04	24,0	48	49,92	1.198
cm 10x60	4"x235/8"		9,4	18	1,08	21,6	48	51,84	1.120
cm 11x90	43/8"x353/8"		10,5	9	0,89	25,0	50	44,55	1.114
cm 15x60	57/8"x235/8"	non rettificato unrectified	8,5	14	1,26	19,5	40	50,40	983
cm 15x90	57/8"x353/8"	non rettificato unrectified	8,5	7	0,95	19,5	48	45,60	885
cm 15x90	57/8"x353/8"		10,5	6	0,81	25,0	48	38,88	972
cm 15x120	57/8"x471/4"		10	5	0,90	24,0	48	43,20	1.037
cm 15x120	57/8"x471/4"		10,5	5	0,90	25,0	48	43,20	1.080
cm 20x120	77/8"x471/4"		10	4	0,96	24,0	42	40,32	968
cm 20x120	77/8"x471/4"		10,5	4	0,96	25,0	42	40,32	1.008
cm 22,5x90	87/8"x353/8"		10,5	5	1,01	25,0	54	54,65	1.366
cm 22,5x180	87/8"x707/8"		10	3	1,22	24,0	40	48,80	1.171
cm 29,5x59	115/8"x231/4"		10	5	0,87	24,0	48	41,76	1.002
cm 29,5x118	115/8"x461/2"		10	3	1,04	24,0	36	37,44	899
cm 30x60	113/4"x235/8"	non rettificato unrectified	9,4	6	1,08	22,0	48	51,84	1.140
cm 30x60	113/4"x235/8"		9,4	6	1,08	21,6	48	51,84	1.120
cm 30x60	113/4"x235/8"		10,5	5	0,90	25,0	48	43,20	1.080
cm 30x120	113/4"x471/4"		10	3	1,08	24,0	36	38,88	933
cm 30x120	113/4"x471/4"		10,5	3	1,08	25,0	36	38,88	972
cm 30x180	113/4"x707/8"		10	2	1,08	24,0	45	48,60	1.166
cm 37,5x75,5	141/2"x293/4"		9	4	1,13	21,0	54	61,02	1.281
cm 37,5x75,5	141/2"x293/4"		10	4	1,13	24,0	48	54,24	1.302
cm 45x90	173/4"x353/8"		10	3	1,22	24,0	30	36,60	878
cm 45x90	173/4"x353/8"		10,5	3	1,22	25,0	30	36,45	911
cm 59x59	231/4"x231/4"		10	4	1,39	24,0	30	41,70	1.001
cm 59x118	231/4"x461/2"		10	2	1,39	24,0	24	33,36	801
cm 60x60	235/8"x235/8"		10	4	1,44	25,0	30	43,20	1.080
cm 60x60	235/8"x235/8"		10,5	4	1,44	25,0	30	43,20	1.080
cm 60x120	235/8"x471/4"		10	2	1,44	24,0	24	34,56	829
cm 60x120	235/8"x471/4"		10,5	2	1,44	25,0	24	34,56	864
cm 75,5x75,5	293/4"x293/4"		10	2	1,14	24,0	45	51,30	1.231
cm 75,5x151	293/4"x291/2"		10	2	2,28	24,0	22	50,16	1.204
cm 90x90	353/8"x353/8"		10	2	1,62	24,0	24	38,88	933
cm 90x90	353/8"x353/8"		10,5	2	1,62	25,0	24	38,88	972
cm 90x180	353/8"x707/8"		10	1	1,62	24,0	30	48,60	1.166

			
BATTISCOPA B.C. BULLNOSE PLINTHE À BORD ARRONDI STEHSOCKEL			
cm 7,5x60	3"x235/8"		18
cm 9x45	31/2"x173/4"		16
cm 9x59	31/4"x235/8"		18
cm 9x60	31/4"x235/8"		18
cm 9x75,5	31/4"x293/4"		8
cm 9x90	31/4"x353/8"		9
cm 9x120	31/4"x471/4"		8
GRADINO STEP TREAD NEZ DE MARCHE STUFENPLATTE			
cm 29,5x59	115/8"x231/4"		6
cm 30x60	113/4"x235/8"		6
cm 30x90	113/4"x353/8"		4
cm 30x120	113/4"x471/4"		3
cm 37,5x75,5	143/4"x293/4"		4
ESAGONO			
cm 30x51,9	113/4"x203/8"		4
CHEVRON A*			
cm 31x29,5	121/4"x115/8"		6

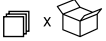
			
CHEVRON B*			
cm 14,6x50	53/4"x193/4"		12
GRADONE ASSEMBLATO			
cm 60x33	235/8"x13"		4
cm 75,5x33	293/4"x13"		-
ANGOLARE ASSEMBLATO			
cm 60x33	235/8"x13"		2
cm 75,5x33	293/4"x13"		-
cm 90x33	353/8"x13"		1
cm 118x33	461/2"x13"		1
cm 120x33	471/4"x13"		1
TOZZETTO INSERT CABOCHON EINLEGER			
cm 9,8x9,8	37/8"x37/8"		33
cm 10x10	4"x4"		33







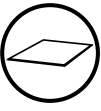

* La scatola contiene 50% dx e 50% sx / The carton contains 50% righthand and 50% leftand
 Le boîte contient 50% dx et 50% sx / Das paket enthält 50% rechtsdekore und 50% linksdekore.

GRESPLUS

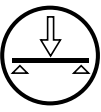
CARATTERISTICHE TECNICHE TECHNICAL FEATURES
CARACTÉRISTIQUES TECHNIQUES TECHNISCHE EIGENSCHAFTEN





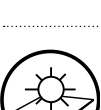







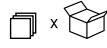

PT0078



	norma standards norme Norm	risultato prova* test results* resultats des essais* Ergebnisse*
 classificazione prodotto product classification classement Klassifizierung	UNI EN 14411-G ISO 13006	gruppo Bla GL completamente greificato group Bla GL fully vitrified group Bla GL grès cérame fin Gruppe Bla GL Feinsteinzeug
 caratteristiche dimensionali e d'aspetto dimensional and surface quality caractéristiques de la surface Oberflächenqualität	UNI EN ISO 10545-2	tolleranze minime nella 1ª scelta very low tolerance des tolérances minimales en 1er choix Entspricht Normen
 assorbimento di acqua water absorption absorption d'eau Wasseraufnahme	UNI EN ISO 10545-3	< 0,1%
 resistenza alla flessione flexural strength résistance à la flexion Biegezug-Festigkeit	UNI EN ISO 10545-4	> 45 N/mm ²
 resistenza al gelo frost resistance résistance au gel Frostwiderstandsfähigkeit	qualsiasi norma all standards toute norme Alle normen	garantita guaranteed garantie Frostsicher
 resistenza attacco chimico (esclusione acido fluoridrico) resistance to acids and alkalis (with the exception of hydrofluoric acid) résistance à l'attaque chimique (exclusion de l'acide fluorhydrique) Säure und Laugen Beständigkeit (mit Ausnahme von Fluorwasserstoff)	UNI EN ISO 10545-13	GA
 dilatazione termica lineare linear thermal expansion coefficient linéaire de dilatation thermique Lineare Wärmeausdehnung	UNI EN ISO 10545-8	6 x 10 ⁻⁶
 resistenza alle macchie stain resistance résistance aux taches Fleckenfestigkeit	UNI EN ISO 10545-14	garantita guaranteed garantie garantiert
 resistenza alla scivolosità (Superficie Naturale) slip resistance (Matt surface) résistance au glissement (Surface naturelle) Trittsicherheit (Natur Oberflächen)	DIN 51130 D.M. N° 236 del 14.06.89	vedere singole serie see every series voir les séries une par une Seihe einzelne Serie valore $\mu > 0,40$
 resistenza dei colori alla luce colour resistance to sunlight exposure résistance de la couleur à la lumière Unveränderlichkeit der Farben wenn Strahlung zugesetzt wird	DIN 51094	nessuna variazione no change of colours couleurs inchangées Keinerlei Farbänderung



▲ Si rimanda all'elenco prodotti UPEC ufficiale, consultabile sul sito: Please see the official UPEC product list:
Veuillez consulter la liste officielle produits UPEC: Sihe die offizielle UPEC-Produktliste auf der Website: <http://webapp.cstb.fr/upec-ceramique/>

* valore indicativo approx value
donnee approximative Ungefähre Werte

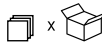
**PESI, MISURE E CONTENUTO DEI COLLI WEIGHT, SIZE AND CONTENTS OF THE PACKING
POIDS, DIMENSIONS, CONTENU DES COLIS VERPACKUNGSGRÖSSEN/GEWICHTE**

		mm ▼ ▲	 x 	 x 	 x 	 x 	 x 	 x 
cm 15x30	5 ⁷ / ₈ "x11 ³ / ₄ "	8	21	0,95	18,0	64	60,48	1.089
cm 20x20	7 ⁷ / ₈ "x7 ⁷ / ₈ "	8,3	30	1,20	16,5	68	81,60	1.346
cm 20x40	7 ⁷ / ₈ "x15 ³ / ₄ "	8,3	18	1,44	16,5	56	80,64	1.331
cm 30x30	11 ³ / ₄ "x11 ³ / ₄ "	8,2	13	1,17	19,0	48	56,16	1.067
cm 30x30	11 ³ / ₄ "x11 ³ / ₄ "	8,9	13	1,17	21,0	48	56,16	1.179
cm 30x60	11 ³ / ₄ "x23 ⁵ / ₈ "	9	6	1,08	21,0	48	51,84	1.089
cm 41,5x41,5	16 ³ / ₈ "x16 ³ / ₈ "	8,8	8	1,38	19,5	48	66,14	1.290
cm 45x45	17 ³ / ₄ "x17 ³ / ₄ "	9	5	1,01	21,0	34	34,41	723
cm 60x60	23 ⁵ / ₈ "x23 ⁵ / ₈ "	20	2	0,72	46	32	23,04	1.060

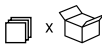
		 x 
BATTISCOPA B.C. BULLNOSE PLINTHE À BORD ARRONDI STEHSOCKEL		
cm 8x30	3 ¹ / ₄ "x11 ³ / ₄ "	30
cm 8x33	3 ¹ / ₄ "x13"	30
cm 8x40	3 ¹ / ₄ "x16"	22
cm 8x41,5	3 ¹ / ₄ "x16 ³ / ₈ "	22
cm 9x30	3 ¹ / ₂ "x11 ³ / ₄ "	30
cm 9x45	3 ¹ / ₂ "x17 ³ / ₄ "	18
GRADINO STEP TREAD NEZ DE MARCHE STUFENPLATTE		
cm 30x30	11 ³ / ₄ "x11 ³ / ₄ "	13
cm 33x33	13"x13"	13

		 x 
GRADONE		
cm 30x30	11 ³ / ₄ "x11 ³ / ₄ " <i>Marmorea</i>	4
cm 30x33	11 ³ / ₄ "x13"	4
GRADONE ANGOLARE		
cm 30x30	11 ³ / ₄ "x11 ³ / ₄ " <i>Marmorea</i>	3
cm 33x33	13"x13"	3
TOZZETTO INSERT CABOCHON EINLEGER		
cm 15x30x3,5	5 ⁷ / ₈ "x11 ³ / ₄ "x 1 ³ / ₈ "	6

**CLASSIFICAZIONE DELLE PIASTRELLE DA PAVIMENTO IN BASE ALL'AMBIENTE DI DESTINAZIONE
CLASSIFICATION OF THE FLOOR TILES ACCORDING TO THE FINAL DESTINATION
CLASSIFICATION DES CARREAUX SELON L'ENTROIT DESTINE
KLASSIFIZIERUNG DER BODENFLIESE NACH IHREM VERWENDUNGSZWECK**

G1 Gruppo 1: Traffico leggero (bagni, camere da letto)
Group 1: Light wear (bathrooms, bedrooms)
Groupe 1: Trafic léger (salles de bains, chambres à coucher)
Gruppe 1: Leichte Beanspruchung (Bade und Schlafzimmer)

G2 Gruppo 2: Traffico-medio (appartamenti privati ad esclusione cucine)
Group 2: Medium wear (private apartments, kitchens excluded)
Groupe 2: Trafic moyen (appartements privés sauf cuisines)
Gruppe 2: Beanspruchung (Privatwohnungen außer Küchen)

G3 Gruppo 3: Traffico medio-forte (appartamenti, case private)
Group 3: Medium hard wear (flats and private houses)
Groupe 3: Trafic mi-fort (appartements et maisons)
Gruppe 3: Mittlere Beanspruchung (Wohnungen und Privätauser)







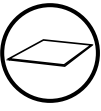

G4 Gruppo 4: Traffico forte (ristoranti, uffici, edifici pubblici)
Group 4: Hard wear (restaurants, offices, public buildings)
Groupe 4: Trafic fort (restaurants, bureaux, édifices publics)
Gruppe 4: Starke Beanspruchung (Restaurant, Büros, öffentliche Gebäude)

ECOGRES

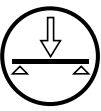
CARATTERISTICHE TECNICHE TECHNICAL FEATURES
CARACTÉRISTIQUES TECHNIQUES TECHNISCHE EIGENSCHAFTEN













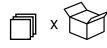

PT0130

	norma standards norme Norm	risultato prova* test results* resultats des essais* Ergebnisse*
 classificazione prodotto product classification classement Klassifizierung	UNI EN 14411-G ISO 13006	gruppo Bla GL completamente greificato group Bla GL fully vitrified group Bla GL grès cérame fin Gruppe Bla GL Feinsteinzeug
 caratteristiche dimensionali e d'aspetto dimensional and surface quality caractéristiques de la surface Oberflächenqualität	UNI EN ISO 10545-2	tolleranze minime nella 1ª scelta very low tolerance des tolérances minimales en 1er choix Entspricht Normen
 resistenza alla flessione flexural strenght résistance a la flexion Biegezug-Festigkeit	UNI EN ISO 10545-4	35÷40 N/mm ²
 resistenza al gelo frost resistance résistance au gel Frostwiderstandsfähigkeit	qualsiasi norma all standards toute norme Alle normen	garantita guaranteed garantie Frostsicher
 resistenza attacco chimico (esclusione acido fluoridrico) resistance to acids and alkalis (with the exception of hydrofluoric acid) résistance à l'attaque chimique (exclusion de l'acide fluorhydrique) Säure und Laugen Beständigkeit (mit Ausnahme von Fluorwasserstoff)	UNI EN ISO 10545-13	GA
 dilatazione termica lineare linear thermal expansion coefficient linéaire de dilatation thermique Lineare Wärmeausdehnung	UNI EN ISO 10545-8	6 x 10 ⁻⁶
 resistenza alle macchie stain resistance résistance aux taches Fleckenfestigkeit	UNI EN ISO 10545-14	garantita guaranteed garantie garantiert
 resistenza alla scivolosità (Superficie Naturale) slip resistance (Matt surface) résistance au glissement (Surface naturelle) Trittsicherheit (Natur Oberflächen)	DIN 51130	vedere singole serie see every series voir les séries une par une Seihe einzelne Serie

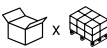
▲ Si rimanda all'elenco prodotti UPEC ufficiale, consultabile sul sito: Please see the official UPEC product list:
Veuillez consulter la liste officielle produits UPEC: Sihe die offizielle UPEC-Produktliste auf der Website: <http://webapp.cstb.fr/upec-ceramique/>

* valore indicativo approx value
donnee approximative Ungefährre Werte

PESI, MISURE E CONTENUTO DEI COLLI WEIGHT, SIZE AND CONTENTS OF THE PACKING
POIDS, DIMENSIONS, CONTENU DES COLIS VERPACKUNGSGRÖSSEN/GEWICHTE

		mm	 x 	 x 	 x 	 x 	 x 	 x 
cm 10x20	4"x7 ⁷ / ₈ "	7,3	60	1,20	15,3	72	86,40	1.322
cm 20x20	7 ⁷ / ₈ "x7 ⁷ / ₈ "	7,3	30	1,20	15,3	72	86,40	1.322
cm 30x60	11 ³ / ₄ "x23 ⁵ / ₈ "	9	6	1,08	20	48	51,84	1.037
cm 33x33	13"x13"	8,2	13	1,42	18	42	59,43	1.070
cm 41,5x41,5	16 ³ / ₈ "x16 ³ / ₈ "	8,8	8	1,38	19,5	48	66,14	1.290
cm 60x60	23 ⁵ / ₈ "x23 ⁵ / ₈ "	9,5	4	1,44	20,4	30	43,20	881

BATTISCOPA B.C. BULLNOSE PLINTHE À BORD ARRONDI STEHSOCKEL

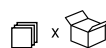

cm 8x33	3 ¹ / ₄ "x13"	30
cm 8x41,5	3 ¹ / ₄ "x16 ³ / ₈ "	25
cm 9x60	3 ¹ / ₂ "x23 ⁵ / ₈ "	18

GRADINO STEP TREAD NEZ DE MARCHE STUFENPLATTE

cm 30x60	11 ³ / ₄ "x23 ⁵ / ₈ "	6
cm 33x33	13"x13"	13

GRADONE

cm 33x33	13"x13"	4
-----------------	---------	---

GRADONE ANGOLARE

cm 33x33	13"x13"	2
-----------------	---------	---

Nel caso le piastrelle Ecogres siano destinate a rivestimento di pareti chiedere espressamente la fornitura dei jolly eventualmente necessari per il rivestimento degli spigoli.

In case Ecogres-Tiles have to be used as wall coverings, customers can expressly request the supply of mitred tiles for outcorners.

Si les carreaux Ecogres sont destinés à un revêtement mural, les clients peuvent demander exprèsment la fourniture de carreaux biseautés (jolly)

Für Wandeläge, können die Kunder eine ausdrückliche Lieferung von Jollys (fliesen mit Fase) für kanten eventuell verlangen.

CLASSIFICAZIONE DELLE PIASTRELLE DA PAVIMENTO IN BASE ALL'AMBIENTE DI DESTINAZIONE
CLASSIFICATION OF THE FLOOR TILES ACCORDING TO THE FINAL DESTINATION
CLASSIFICATION DES CARREAUX SELON L'ENTROIT DESTINE
KLASSIFIZIERUNG DER BODENFLIESE NACH IHREM VERWENDUNGSZWECK

G1 Gruppo 1: Traffico leggero (bagni, camere da letto)

Group 1: Light wear (bathrooms, bedrooms)

Groupe 1: Trafic léger (salles de bains, chambres à coucher)

Gruppe 1: Leichte Beanspruchung (Bade und Schlafzimmer)

G2 Gruppo 2: Traffico-medio (appartamenti privati ad esclusione cucine)

Group 2: Medium wear (private apartments, kitchens excluded)

Groupe 2: Trafic moyen (appartements privés sauf cuisines)

Gruppe 2: Beanspruchung (Privatwohnungen außer Küchen)

G3 Gruppo 3: Traffico medio-forte (appartamenti, case private)

Group 3: Medium hard wear (flats and private houses)

Groupe 3: Trafic mi-fort (appartements et maisons)

Gruppe 3: Mittlere Beanspruchung (Wohnungen und Privtäuser)

G4 Gruppo 4: Traffico forte (ristoranti, uffici, edifici pubblici)

Group 4: Hard wear (restaurants, offices, public buildings)

Groupe 4: Trafic fort (restaurants, bureaux, édifices publics)

Gruppe 4: Starke Beanspruchung (Restaurant, Büros, öffentliche Gebäude)

STONALIZZAZIONE SHADE VARIATIONS VARIATIONS D'OMBRE FARBTONVARIANTEN

La stonalizzazione indica il livello di variazione cromatica che sussiste, all'interno della stessa collezione fra una piastrella e l'altra.

The colour shading scale denotes the level of colour variation that exists between specific tiles in the same collection.

La « stonalisation » est le degré de variation chromatique qui existe entre un carreau et un autre de la même collection.

Die Schattierung zeigt den Grad der chromatischen Variation an, die innerhalb derselben Kollektion zwischen den einzelnen Fliesen besteht.

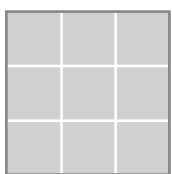

Uniforme
Uniform
Uniforme
Einheitlich

V1

L'aspetto delle piastrelle è uniforme. Differenze minime fra i prodotti appartenenti al medesimo lotto produttivo.

The appearance of the tiles is uniform. There are minimal differences in products belonging to the same production batch.

L'aspect des carreaux est uniforme. Les différences entre les produits appartenant à un même lot de production sont minimales.

Der optische Aspekt der Fliesen ist einheitlich. Die Unterschiede zwischen Produkten derselben Produktionscharge sind minimal.

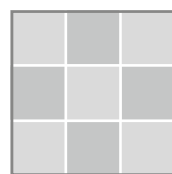

Leggera
Subtle
Légère
Leicht

V2

L'aspetto delle piastrelle presenta leggere ma visibili differenze, che si tratti di segni grafici o sfumature/venature tipiche del materiale naturale di riferimento.

There are subtle yet visible differences in the appearance of the tile, whether these are clear markings or the typical shading/veining of the natural material in question.

L'aspect des carreaux présente des différences légères mais visibles, qu'il s'agisse de marques graphiques ou de nuances/veinures typiques du matériau naturel de référence.

Der optische Aspekt der Fliesen weist leichte aber sichtbare Unterschiede auf, wobei es sich um graphische Zeichnungen oder Schattierungen/Maserungen handelt, die für das natürliche Referenzmaterial typisch sind.



Media
Medium
Moyenne
Mittel

V3

L'aspetto delle piastrelle presenta variazioni di colore e/o struttura decisi. Questa variabilità cromatica è appositamente studiata in fase di progettazione della collezione per rendere il prodotto il più vicino possibile al materiale naturale di riferimento.

There are clear variations in the colour and/or structure of the tiles. This dynamic colour variation is meticulously planned during the collection design phase in order to make the product as similar as possible to the natural material in question.

L'aspect des carreaux présente des variations de couleur et/ou de structure marquées. Le caractère variable de la couleur est spécialement étudié lors de la conception de la collection pour rendre le produit le plus proche possible du matériau naturel de référence.

Der optische Aspekt der Fliesen weist deutliche Farb- und/oder Strukturunterschiede auf. Diese chromatische Variabilität wurde in der Designphase der Kollektion speziell entwickelt, um das Produkt seinem natürlichen Referenzmaterial so ähnlich wie möglich zu machen.



Accentuata
Accentuated
Forte
Akzentuiert

V4

L'aspetto delle piastrelle presenta variazioni importanti di colore e/o di struttura, rendendole, in alcuni casi, completamente diverse tra loro.

There are significant variations in the colour and/or structure of the tiles. In some cases, one tile can appear completely different to the next.

L'aspect des carreaux présente d'importantes variations de couleur et/ou de structure, ce qui les rend, dans certains cas, complètement différentes entre elles.

Der optische Aspekt der Fliesen weist bedeutende Farb- und/oder Strukturunterschiede auf, durch die sie sich in einigen Fällen vollständig voneinander abheben.

COMPLEMENTI
IN ACCIAIO E ALLUMINIO
 ACCESSORIES IN STEEL
 AND ALUMINIUM
COMPLÉMENTS EN
ACIER ET EN ALUMINIUM
 TECHNISCHE
 EIGENSCHAFTEN

terminale alluminio



cm 1x30 - $\frac{3}{8}$ "x $1\frac{3}{4}$ "

matita alluminio



cm 1,2x30 - $\frac{1}{2}$ "x $1\frac{3}{4}$ "

tozzetto alluminio



cm 1,5x1,5 - $\frac{5}{8}$ "x $\frac{5}{8}$ "

angolo terminale alluminio



cm 1x1 - $\frac{3}{8}$ "x $\frac{3}{8}$ "

matita acciaio



cm 0,3x60 - $\frac{1}{4}$ "x $2\frac{3}{8}$ "

bacchetta alluminio



cm 0,3x60 - $\frac{1}{4}$ "x $2\frac{3}{8}$ "

VOCI DI CAPITOLATO
SPECIFICATIONS
CAHIER DES CHARGES
AUSSCHREIBUNGSTEXTE

GRANITOGRES

Piastrelle in gres porcellanato antiusura e antimacchia, ingelive, in prima scelta, pressate, *non smaltate e con effetti cromatici ottenuti solo con colorazione in massa*, pienamente vetrificate come da norme UNI EN ISO 14411-G - Gruppo B1a UGL - con assorbimento d'acqua <0,1%, ottenute da miscele selezionate di argille, quarzi e feldspati cotte a temperatura di 1250°C tipo **Granitogres** di **Casalgrande Padana**, con superficie..., formato..., spessore..., colore..., serie..., scelte dalla direzione lavori, per i seguenti locali: ...

Supply of wear-resistant, stain-proof, frost proof, first grade, pressed, *unglazed porcelain stoneware tiles with chromatic effects obtained by full body colouring only*, fully vitrified in accordance with standards UNI EN ISO 14411-G - Group B1a UGL - with <0.1% water absorption. Obtained by selected mixtures of clay, quartz and feldspars fired at 1250°C, type **Granitogres** by **Casalgrande Padana**, with surface textures..., formats..., thickness..., colour..., series..., chosen by the works management for the following places: ...

Fourniture de carreaux de grès cérame résistant à l'usure, aux tâches et au gel, en premier choix, pressés, *non émaillés et à effets chromatiques obtenus seulement par coloration dans la masse*, pleinement vitrifiés conformément aux normes UNI EN ISO 14411-G - Groupe B1a UGL - absorption d'eau <0,1%, obtenus à partir de mélanges sélectionnés d'argiles, quartz et feldspaths cuits à des températures de 1250°C type **Granitogres** de **Casalgrande Padana**, à surface..., format..., épaisseur..., couleur..., série..., choisis par la direction des travaux pour les locaux suivants : ...

Lieferung vor Feinsteinzeugplatten, verschleißfest und fleckenfest, frostsicher, in erster Wahl, gepresst, *unglasiert mit chromatischen Effekten, die sich nur durch die Einfärbung der gesamten Masse erhalten lassen*, voll durchgesintert nach den Normen UNI EN ISO 14411-G - Gruppe B1a UGL - mit Wasseraufnahme <0,1%, erhalten aus ausgesuchten Mischungen von Tonerden, Quarzen und Feldspaten, bei einer Temperatur von 1250°C gebrannt, Typ **Granitogres** von **Casalgrande Padana**, mit Oberflächen..., Format..., Stärke..., Farbe..., Serie..., von der Bauleitung für die folgenden Räume gewählt: ...

PIETRE NATIVE

Piastrelle in gres porcellanato antiusura e antimacchia, ingelive, in prima scelta, pressate, colorate in massa, pienamente vetrificate come da norme UNI EN ISO 14411-G - Gruppo B1a - con assorbimento d'acqua <0,1%, ottenute da miscele selezionate di argille, quarzi e feldspati cotte a temperatura di 1250°C tipo **Pietre Native** di **Casalgrande Padana**, con superficie..., formato..., spessore..., colore..., serie..., scelte dalla direzione lavori, per i seguenti locali: ...

Supply of wear-resistant, stain proof, frost proof, first grade, pressed, full body coloured porcelain stoneware tiles, fully vitrified in accordance with standards UNI EN ISO 14411-G - Group B1a - with <0.1% water absorption. Obtained by selected mixtures of clay, quartz and feldspars fired at 1250°C, type **Pietre Native** by **Casalgrande Padana**, with surface textures..., formats..., thickness..., colour..., series..., chosen by the works management for the following places: ...

Fourniture de carreaux de grès cérame résistant à l'usure, aux tâches et au gel, en premier choix, pressés, colorés dans la masse, pleinement vitrifiés conformément aux normes UNI EN ISO 14411-G - Groupe B1a - absorption d'eau <0,1%, obtenus à partir de mélanges sélectionnés d'argiles, quartz et feldspaths cuits à des températures de 1250°C type **Pietre Native** de **Casalgrande Padana**, à surface..., format..., épaisseur..., couleur..., série..., choisis par la direction des travaux pour les locaux suivants : ...

Lieferung vor Feinsteinzeugplatten, verschleißfest und fleckenfest, frostsicher, in erster Wahl, gepresst, in der Masse durchgefärbt, voll durchgesintert nach den Normen UNI EN ISO 14411-G - Gruppe B1a - mit Wasseraufnahme <0,1%, erhalten aus ausgesuchten Mischungen von Tonerden, Quarzen und Feldspaten, bei einer Temperatur von 1250°C gebrannt, Typ **Pietre Native** von **Casalgrande Padana**, mit Oberflächen..., Format..., Stärke..., Farbe..., Serie..., von der Bauleitung für die folgenden Räume gewählt: ...

GRANITOKER

Piastrelle in gres porcellanato, antimacchia e ingelive, in prima scelta colorate in massa, pienamente vetrificate, come da norme UNI EN ISO 14411-G - Gruppo B1a GL - con assorbimento d'acqua < 0,1%, ottenute da miscele selezionate di argille, quarzi e feldspati cotte a temperatura di 1250°C, tipo **Granitoker** di **Casalgrande Padana** con superficie..., formato..., spessore..., colore..., serie..., scelte dalla direzione lavori, per i seguenti locali: ...

Supply of stain proof, frost proof, first grade, body coloured porcelain stoneware tiles, fully vitrified, in accordance with standards UNI EN ISO 14411-G - Group B1a GL - with < 0.1% water absorption. Obtained by selected mixtures of clay, quartz and feldspars fired at 1250°C, type **Granitoker** by **Casalgrande Padana**, with surface textures..., formats..., thickness..., colour..., series..., chosen by the works management for the following places: ...

Fourniture de carreaux de grès cérame résistant aux tâches et au gel, en premier choix, colorés dans la masse, pleinement vitrifiés conformément aux normes UNI EN ISO 14411-G - Groupe B1a GL - absorption d'eau < 0,1%, obtenus à partir de mélanges sélectionnés d'argiles, quartz et feldspaths cuits à des températures de 1250°C type **Granitoker** de **Casalgrande Padana**, à surface..., format..., épaisseur..., couleur..., série..., choisis par la direction des travaux pour les locaux suivants : ...

Lieferung von Feinsteinzeugplatten, fleckenfest und frostsicher, in erster Wahl, in der Masse durchgefärbt, voll durchgesintert, nach den Normen UNI EN ISO 14411-G - Gruppe B1a GL - mit Wasseraufnahme < 0,1%, erhalten aus ausgesuchten Mischungen von Tonerden, Quarzen und Feldspaten, bei einer Temperatur von 1250°C gebrannt, Typ **Granitoker** von **Casalgrande Padana** mit Oberflächen..., Format..., Stärke..., Farbe..., Serie..., von der Bauleitung für die folgenden Räume gewählt: ...

GRESPLUS

Piastrelle in gres porcellanato, antimacchia e ingelive, in prima scelta smaltate, pienamente vetrificate, come da norme UNI EN 14411 ISO 13006 - Gruppo BI a GL - con assorbimento d'acqua 0,1%, ottenute da miscele selezionate di argille, quarzi e feldspati cotte a temperatura di 1250°C, tipo **Gresplus** di **Casalgrande Padana** con superficie..., formato..., spessore..., colore..., serie..., scelte dalla direzione lavori, per i seguenti locali: ...

Supply of stain proof, frost proof, first grade, glazed, fully vitrified porcelain stoneware tiles, in accordance with standards UNI EN 14411-G ISO 13006 - Group BIa GL - with 0.1% water absorption. Obtained by selected mixtures of clay, quartz and feldspars fired at 1250°C, type **Gresplus** by **Casalgrande Padana**, with surface textures..., formats..., thickness..., colour..., series..., chosen by the works management for the following places: ...

Fourniture de carreaux de grès cérame résistant aux tâches et au gel, en premier choix, émaillés, pleinement vitrifiés conformément aux normes UNI EN 14411-G ISO 13006 - Groupe BI a GL - absorption d'eau 0,1%, obtenus à partir de mélanges sélectionnés d'argiles, quartz et feldspaths cuits à des températures de 1250°C type **Gresplus** de **Casalgrande Padana**, à surface..., format..., épaisseur..., couleur..., série..., choisis par la direction des travaux pour les locaux suivants : ...

Lieferung von Feinsteinzeugplatten, fleckenfest und frostsicher, in erster Wahl, glasiert, voll durchgesintert, nach den Normen UNI EN 14411-G ISO 13006 - Gruppe BIa GL - mit Wasseraufnahme 0,1%, erhalten aus ausgesuchten Mischungen von Tonerden, Quarzen und Feldspaten, bei einer Temperatur von 1250°C gebrannt, Typ **Gresplus** von **Casalgrande Padana** mit Oberflächen..., Format..., Stärke..., Farbe..., Serie..., von der Bauleitung für die folgenden Räume gewählt: ...

ECOGRES

Piastrelle in monocottura in pasta bianca, in prima scelta, pressate, smaltate, tipo **Ecogres** di **Casalgrande Padana**, come da norme UNI EN 14411 ISO 13006 - Gruppo BII a GL - (BI b GL per i formati 10x20 e 20x20) con superficie..., formato..., spessore..., colore..., serie..., scelte dalla direzione lavori, per i seguenti locali: ...

Casalgrande Padana's Ecogres first-choice single-fired, white body, pressed enamelled tiles comply with EN 14411 and ISO 13006 - Group B2a GL - (B1b GL for 10x20 and 20x20 formats). Surface: ...; format: ...; thickness ...; colour: ...; series: ..., chosen by Construction Supervision for the following rooms: ...

Carreaux en monocuisson à pâte blanche, de premier choix, pressés, émaillés, type **Ecogres** de **Casalgrande Padana**, conformément aux normes UNI EN 14411 ISO 13006 - Groupe BII à GL - (BIb GL pour les formats 10x20 et 20x20) avec surface..., format..., épaisseur..., couleur..., série..., choisis par le maître d'ouvrage, pour les locaux suivants : ...

Einbrandfliese weißscherbig, erste Wahl, gepresst, lackiert, Typ **Ecogres** von **Casalgrande Padana**, konform mit DIN EN 14411 / ISO 13006 - Gruppe BII bis GL - (Formate 10x20 und 20x20: BI b GL) Oberfläche: ...; Format: ...; Stärke: ...; Farbe: ...; Serie: ...; ausgewählt von der Bauleitung für folgende Räume: ...

POSA
E MANUTENZIONE
INSTALLATION
AND MAINTENANCE
POSE ET ENTRETIEN
VERLEGUNG
UND PFLEGE

POSA IN OPERA

La riuscita di un pavimento è dovuta non solo alla qualità delle piastrelle, ma a tutto un insieme di elementi (sottofondo, strato legante, giunti di dilatazione, ecc.) che costituiscono un vero e proprio sistema. Ecco perché le operazioni di posa sono da considerarsi importanti tanto quanto la scelta delle piastrelle.

È comunque compito del progettista stabilire, in funzione della struttura e della destinazione d'uso del piano di calpestio, il corretto modo di applicazione delle piastrelle e il tipo di piastrella da utilizzare.

Le piastrelle **Casalgrande Padana** non si differenziano, per quanto riguarda le operazioni di posa, da una qualsiasi altra ceramica e si può quindi seguire sia il sistema tradizionale con malta cementizia, che quello con collanti o adesivi. Per i formati oltre il 30x30 cm è consigliabile ricorrere ad un sistema di posa con adesivo, da prescrivere in funzione dell'ambiente di destinazione, della tipologia e delle caratteristiche del supporto di posa, del formato considerato e dei carichi statici/dinamici agenti sulla piastrellatura ceramica.

Ricorrendo alla posa con adesivo è inoltre necessario verificare, prima di procedere alla posa, che il supporto possieda idonee caratteristiche per l'incollaggio della ceramica, quali: stabilità e regolarità dimensionale, rigidità, assenza di fessurazioni, pulizia e integrità superficiale, assenza di umidità in eccesso e/o di agenti contaminanti.

Prima di iniziare le operazioni di posa di una qualsiasi superficie si raccomanda di accertarsi che la partita di grès sia adeguata e sufficiente per quantità, tono e calibro, a quella necessaria. Si dovranno poi seguire tutte le norme e le precauzioni che sono alla base di una corretta esecuzione del lavoro (preparazione del sottofondo, composizione della malta o dei collanti, tempi di maturazione, posizionamento dei giunti di dilatazione, battitura, ecc.).

Se per ambienti di grandi dimensioni è assolutamente necessario posizionare i giunti con regolarità, per piccoli ambienti è sufficiente lasciare un leggero stacco fra piastrellato e muri perimetrali. Sarà poi il battiscopa a coprire lo stacco dando un aspetto di finitura.

Evitare il transito sul pavimento per almeno 2/3 giorni dopo la posa. In caso di necessità di transito si dovrà predisporre un tavolato appoggiato sul pavimento.

Successivamente alla posa si raccomanda di proteggere adeguatamente il pavimento sino al termine del cantiere in modo tale

da evitare danni causati da sostanze abrasive o da altri agenti dannosi.

Tenere presente che, nel caso di posa col sistema tradizionale e in mancanza di particolari additivi nella malta, è necessario attendere anche un mese prima di sottoporre il pavimento a sollecitazioni e carichi di esercizio. Le piastrelle **Casalgrande Padana** pur essendo materiale molto resistente, possono essere sagomate o perforate per l'installazione di impianti tecnico sanitari, utilizzando una attrezzatura adeguata.

MANUTENZIONE E PULIZIA DI PAVIMENTI E RIVESTIMENTI

Un pavimento o rivestimento murale

Casalgrande Padana sia nella versione naturale che lappata, lucida, o levigata, è sinonimo di bellezza, durata e resistenza nel tempo.

La sua manutenzione non richiede particolari cure se non l'attenersi alle seguenti norme di pulizia.

Prima pulizia

Ha lo scopo di eliminare ogni traccia di cemento o stucco conseguente alla chiusura dei giunti.

Si esegue normalmente una sola volta prima dell'utilizzo del pavimento/rivestimento e deve essere obbligatoriamente eseguita dopo la posa in opera e prima dell'uso del pavimento/rivestimento.

Procedere nel modo seguente:

1. Spazzare il pavimento/rivestimento raccogliendo lo sporco grossolano.
2. Inumidire con acqua la superficie affinché le fughe vengano impregnate e pertanto protette dall'azione corrosiva del detergente a componente acida (decalcificante).
3. Stendere il detergente (*vedi nota A*) nella concentrazione (rapporto di miscelazione con l'acqua) indicata dal produttore, applicandolo con una spazzola manuale o motorizzata. **Per la serie Metallica utilizzare detergenti molto diluiti (diluizione 1-5, 1 parte di acido e 5 parti di acqua) e assicurarsi in particolare un abbondante risciacquo seguito da asciugatura completa del pavimento.** Evitare che il detergente acido venga a contatto con componenti di acciaio, alluminio e marmo naturale adiacenti al pavimento/rivestimento.
4. Durante il tempo d'azione, che deve essere stabilito in relazione allo stato del pavimento, strofinare lo sporco più ostinato (e raschiare eventuali residui di malta, stucco, etc...).

5. Sciacquare il pavimento/rivestimento con acqua e raccogliere subito l'acqua sporca (manualmente o con un apparecchio lavasciuga).

Se la prima pulizia viene eseguita dopo che il pavimento/rivestimento è già stato usato, sarà bene, prima dell'applicazione del detergente a base acida, togliere con appositi detersivi alcalini (sgrassanti) eventuali presenze di sostanze grasse o simili (*vedi Pulizia ordinaria*).

L'operazione di prima pulizia, se ritenuto necessario, può essere ripetuta.

Superficie levigata, lucida e lappata

Una leggera diminuzione della lucentezza dei pavimenti levigati, a seguito del primo lavaggio acido del pavimento, deve essere considerata normale, perché dovuta alla eliminazione dei residui degli abrasivi utilizzati nella lavorazione della superficie.

A Alcuni detersivi consigliati per eliminare i residui di stucco:

Fughe realizzate con stucco cementizio - detersivi a componente acida (decalcificanti)
Deterprimo plus (Casalgrande Padana), Deterdek (Fila), Keranet (Mapei), Deltaplus (Kerakoll), Solvacid (Geal) o simili (seguire istruzioni del produttore del detergente).

Fughe realizzate con stucco epossidico - detersivi a componente alcalina

Fuga-Soap Eco (Kerakoll), Kerapoxy Cleaner (Mapei), Tile Cleaner (Faber), CR10 (Fila), Lithofin Resin-Ex (Lithofin), Eposolv (Geal) o simili (seguire istruzioni del produttore del detergente).

Pulizia ordinaria

Per la pulizia di tutti i giorni è sufficiente lavare il pavimento/rivestimento con acqua e aggiunta di normali prodotti detersivi adatti a pulire superfici ceramiche (per i rivestimenti utilizzare detersivi in gel). Assicurarsi che i detersivi non contengano sostanze cerosi; la superficie dei prodotti **Casalgrande Padana**, essendo praticamente inassorbente, non richiede l'applicazione di cere e/o prodotti siliconici di protezione che, al contrario, non debbono mai essere usati (possono creare un film superficiale che andrebbe a modificare le caratteristiche naturali del grès porcellanato).

In presenza di macchie persistenti e difficili da togliere con la pulizia ordinaria, intervenire con impiego di detersivi più concentrati lasciando agire gli stessi per un adeguato

intervallo di tempo e, successivamente, strofinare con adeguata intensità, fino a ricondurre le piastrelle all'aspetto originario. Al riguardo è opportuno segnalare che il grès è resistente a qualsiasi sostanza chimica, **eccezion fatta per l'acido fluoridrico che attacca tutti i prodotti ceramici e che, quindi, non deve mai essere utilizzato.**

Per la pulizia di pavimenti in aree pubbliche si consiglia di intervenire dopo la chiusura dei locali, affinché il pavimento alla riapertura sia asciutto; in alternativa isolare il pavimento pulito fino alla sua completa asciugatura. Per i locali di maggiore estensione è opportuno disporre di macchine lavasciuga, per assicurare una perfetta pulizia e igienicità.

Il pavimento deve essere considerato pulito quando riacquista il suo aspetto originario!

INSTALLATION

The successful installation of floors depends not only on the quality of tiles but on a combination of factors (bedding, binding layer, expansion joints, etc.) that constitute a real system.

That is why installation operations are to be considered as important as the choice of tiles. However, based on the structure and purpose of the flooring surface, the designer is still responsible for defining the correct procedure to lay the tiles and selecting the ones to be employed. When it comes to installation operations, **Casalgrande Padana** do not differ from any other type of ceramic: either the traditional procedure envisaging cement mortar or the procedure envisaging glues and adhesives may be resorted to.

For tiles larger than 30x30 cm, we recommend using an installation system with an adhesive according to the intended use of the room, type and characteristics of the substrate, and size in consideration of the static/dynamic loads on the ceramic tiles. If you use an adhesive, you must first ensure that the substrate has suitable characteristics for glueing ceramics, such as stability and dimensional regularity, rigidity, absence of cracks, clean and intact surface, and absence of excess moist and/or contaminants.

Before starting the installation operations of any surface, we recommend you make sure that the stoneware batch is adequate and sufficient in terms of quantity, tone and calibration.

Moreover, all necessary norms and precautions need to be implemented for the correct completion of the work (bedding preparation, composition of mortar or adhesives, maturing period, positioning expansion joints, ramming, etc.).

If in case of large environments joints must be positioned at regular intervals, in small environments a small gap between the tiles and perimeter walls is sufficient: the skirting board will cover the gap and provide the finishing effect. Avoid walking on the floor for at least 2/3 days after installation.

If walking on the floor is necessary, lay wooden planks on the surface.

After laying, it is recommended to adequately protect the floor until finished in order to avoid damage caused by abrasive substances or other harmful agents. Please notice that if the tiles are installed with the traditional procedure and no additives are added to the mortar, at least one month has to elapse before the floor can be subjected to stress and operating loads. Even though **Casalgrande Padana** tiles are very resilient material, they can be shaped or perforated to install technical and sanitary systems, using appropriate equipment.

MAINTENANCE AND CLEANING OF THE FLOORING AND WALL COVERINGS

A **Casalgrande Padana** flooring or wall covering, whether natural, lapped, lucida or polished, is synonym with beauty, strength and a long life.

These surfaces are low maintenance and only need be cleaned as described below.

First clean

The purpose of first-time cleaning is to remove any trace of cement or plaster used to close the joints. The flooring/wall covering is normally cleaned once before use. This must be done after installation and before use.

Proceed as follows:

1. Sweep the floor/covering to remove the coarser dirt.
2. Dampen the surface with water so as to soak the joints, thereby protecting them from the corrosive action of the acid detergent (descaling product).
3. Apply the detergent (*see note A*) in the concentration (water mixing ratio) indicated by the manufacturer using a manual or motorised brush. **With regards to the Metallica series, use very diluted detergents (1-5 dilution i.e., 1 part acid**

POSA E MANUTENZIONE INSTALLATION AND MAINTENANCE POSE ET ENTRETIEN VERLEGUNG UND PFLEGE

to 5 parts water), rinse thoroughly, and leave the floor to dry completely. Avoid any contact between the acid detergent and the steel, aluminium, and natural marble components near the flooring/wall covering.

4. Leave it as long as needed depending on the condition of the floor, then rub any stubborn dirt away (such as mortar, plaster, etc. ...).
5. Rinse the flooring/covering with water and mop up the dirty water immediately (manually or with a washer/drier).

If the flooring/wall covering is cleaned for the first time after being used, it is important to use appropriate alkaline detergents (degreasing agents) before applying the acid detergent to remove any greasy or similar substance (see *Routine Cleaning*).

If necessary, you can repeat the first-time cleaning operations described above.

Polished, lucida and lapped surfaces

A slight loss of shine after the first acid wash must be considered normal, as it is due to the removal of the abrasive residues used for processing the surface.

A Here are a few detergents recommended for removing plaster residues:

Cement plaster joints – acid detergents (descaling products)

Deterprimo Plus (Casalgrande Padana), Deterdek (Fila), Keranet (Mapei), Deltaplus (Kerakoll), Solvacid (Geal) or similar detergents (follow the manufacturer's instructions).

Epoxy plaster joints – alkaline detergents

Fuga-Soap Eco (Kerakoll), Kerapoxy Cleaner (Mapei), Tile Cleaner (Faber), CR10 (Fila), Lithofin Resin-Ex (Lithofin), Eposolv (Geal) or similar detergents (follow the manufacturer's instructions).

Routine cleaning

For everyday cleaning, all you have to do is wash the flooring/wall covering with water and normal neutral detergents suitable for ceramic surfaces (for wall coverings use a neutral gel detergent gel).

Make sure that the detergents do not contain waxy substances. The surface of **Casalgrande Padana** products are practically non-absorbent; therefore, the use of wax and/or silicone cleaners is not required.

These should never be used, as they create a superficial film that changes the natural characteristics of porcelain stoneware. Should there be any stubborn stain that cannot be removed by routine cleaning, use a more concentrated detergent and leave it on for long enough, then rub harder until the tiles are back to their original condition. Note that porcelain stoneware is resistant to any chemical, **except hydrofluoric acid, which eats into any ceramic, so it must never be used.**

Floors of public areas should be cleaned when the place is closed, so the floor will be dry when it reopens; otherwise, fence off the cleaned floor until perfectly dry.

For larger places, use a washer/drier to ensure perfect cleanliness and hygiene.

The flooring is to be considered clean when it returns to its original appearance!

POSE

Un bon sol dépend non seulement de la qualité des carreaux, mais aussi de toute une série d'éléments qui constituent un seul tout (couche de fond, couche d'un agent liant, joints de dilatation, etc.). C'est pourquoi les opérations de pose sont tout aussi importantes que le choix du carrelage. Il appartient à l'architecte d'établir le type de carrelage à utiliser en fonction du lieu et de l'utilisation du sol ainsi que la meilleure méthode de pose des carreaux. En ce qui concerne les opérations de pose, les séries **Casalgrande Padana** ne sont pas différentes des autres carreaux céramiques et il est donc possible de suivre la méthode traditionnelle en utilisant du mortier de ciment ou d'utiliser des colles ou autres produits adhésifs. Pour les formats excédant 30x30 cm, il est conseillé de recourir à un système de pose avec de l'adhésif, à adopter en fonction de l'environnement de destination, de la typologie et des caractéristiques du support de pose, du format envisagé et des charges statiques/dynamiques appliquées sur le carrelage en céramique.

Avant de procéder à ce type de pose, il est également nécessaire de s'assurer que le support possède les caractéristiques appropriées pour le collage de la céramique. Ces caractéristiques sont les suivantes : stabilité et régularité dimensionnelle, rigidité, absence de fissures, nettoyage et intégrité de la surface, absence d'excès d'humidité et/ou d'agents de contamination.

Avant de commencer les opérations de pose, il est recommandé de vérifier que les lots de carreaux en grès correspondent bien à la quantité, à la couleur et au calibre nécessaires.

Il faut ensuite respecter toutes les normes et les précautions qui sont à la base de la bonne exécution des travaux (préparation de la couche de fond, composition du mortier ou des colles, positionnement des joints de dilatation, nivellement à l'aide du maillet, temps de séchage, etc.). Pour les grandes surfaces, il est absolument nécessaire de positionner les joints avec la plus grande régularité, tandis que pour les petites surfaces, il suffira de laisser un léger écart entre le carrelage et les murs périmétraux.

Ce seront ensuite les plinthes qui couvriront l'écart pour donner l'aspect de finition.

Après la pose, éviter de marcher sur le sol pendant au moins 2 ou 3 jours.

Si le passage s'avère nécessaire, il faudra poser des planches sur le sol.

Après la pose, il est recommandé de protéger le sol de manière adéquate jusqu'à la fin des travaux afin d'éviter tout dommage pouvant être causé par des substances abrasives ou par d'autres agents nocifs.

Ne pas oublier qu'en cas de pose en suivant la méthode traditionnelle et en absence d'additifs particuliers dans le mortier, il faut attendre même un mois avant de soumettre le sol à toute charge et/ou sollicitation. Même si les carreaux des séries **Casalgrande Padana** sont extrêmement résistants, ils peuvent être façonnés et perforés pour installer les équipements technico-sanitaires en utilisant les outils appropriés.

ENTRETIEN ET NETTOYAGE DES REVÊTEMENTS DE SOL ET DE MUR

Les revêtements de sol et de mur de **Casalgrande Padana**, qu'ils soient en version naturelle, poncée, brillante ou polie, sont synonymes de beauté, de solidité et de durabilité. Ils n'exigent aucune opération d'entretien particulière, il suffit de suivre les conseils d'entretien suivants :

Premier nettoyage

Son but est d'éliminer toute trace de ciment ou de mortier-colle après le jointoiement. Cette opération est généralement effectuée une seule fois avant d'utiliser le revêtement sol/mur, et il faut obligatoirement l'effectuer après la pose

et avant toute utilisation du revêtement sol/mur. Procéder de la manière suivante :

1. Balayer/épousseter le revêtement sol/mur en éliminant toutes traces d'impuretés.
2. Humidifier la surface avec de l'eau de manière à bien imprégner les joints afin qu'ils soient ainsi bien protégés de l'action corrosive du nettoyant acide (décalcifiant).
3. Respecter la concentration (quantité à diluer dans l'eau) indiquée par le fabricant pour l'utilisation du produit nettoyant, et appliquer le produit (*voir note A*) à l'aide d'une brosse manuelle ou motorisée.
Pour la série Metallica, utiliser des nettoyeurs acides après les avoir bien dilués dans l'eau (rapport 1-5, 1 part d'acide et 5 parts d'eau), puis veiller à bien rincer et à essuyer complètement le sol. Veillez à ce que le nettoyant acide n'entre pas en contact d'éléments en acier et en aluminium, ou d'éléments en marbre naturel placés à proximité du revêtement sol/mur.
4. Pendant le temps d'action du produit, à établir en fonction de l'état du sol, frotter les taches les plus persistantes (et racler d'éventuels résidus de mortier, de mortier-colle, etc.).
5. Rincer le revêtement sol/mur avec de l'eau, puis éliminer immédiatement l'eau sale (à la main ou avec un appareil de nettoyage à aspiration d'eau).

Si le premier nettoyage est effectué après avoir utilisé le revêtement sol/mur, avant d'appliquer le nettoyant acide, il est conseillé d'éliminer toute éventuelle trace de substance grasse ou similaire en utilisant les nettoyeurs alcalins (dégraissants) prévus à cet effet (*voir Nettoyage ordinaire*). S'il y a lieu, répéter cette première opération de nettoyage.

Surfaces polies, brillantes et poncées

Après le premier lavage avec le nettoyant acide, une légère diminution de la brillance des sols polis doit être considérée normale, étant due à l'élimination des résidus abrasifs utilisés lors du traitement de surface effectué en usine.

A Voici certains nettoyeurs conseillés pour éliminer les résidus de mortier-colle :

Joints réalisés en mortier-ciment – nettoyeurs acides (décalcifiants)

Deterprimo plus (Casalgrande Padana), Deterdek (Fila), Keranet (Mapei), Deltaplus (Kerakoll), Solvacid (Geal) ou produits similaires (suivre les instructions du fabricant du produit nettoyant).

Joints réalisés en mortier-époxy – nettoyeurs alcalins

Fuga-Soap Eco (Kerakoll), Kerapoxy Cleaner (Mapei), Tile Cleaner (Faber), CR10 (Fila), Lithofin Resin-Ex (Lithofin), Eposolv (Geal) ou produits similaires (suivre les instructions du fabricant du produit nettoyant).

Nettoyage ordinaire

Pour le nettoyage quotidien, il suffit de laver le revêtement sol/mur avec de l'eau en y diluant des produits nettoyeurs adaptés aux surfaces en céramique (pour les murs, utiliser des produits nettoyeurs sous forme de gel). S'assurer que les produits nettoyeurs ne contiennent pas de substances à base de cire ; la surface des produits **Casalgrande Padana** étant pratiquement non absorbante, il n'y a aucun besoin de passer ni cire ni autre produit similaire de protection à base de silicone ; bien au contraire, ces produits ne doivent jamais être utilisés (ils pourraient créer un film superficiel susceptible de modifier les caractéristiques naturelles du grès cérame).

Néanmoins, en cas de taches persistantes et difficiles à éliminer par un nettoyage ordinaire, utiliser un produit nettoyant plus puissant en le laissant agir pendant un temps adéquat, puis frotter énergiquement jusqu'à ce que le carrelage retrouve son aspect d'origine. Il est intéressant de signaler que le grès résiste aux substances chimiques, à l'exception de l'acide fluorhydrique qui attaque tous les produits céramiques et qui ne doit donc jamais être utilisé.

Pour le nettoyage de lieux publics, il est conseillé d'effectuer l'entretien après la fermeture des locaux, afin que le sol soit bien sec avant la réouverture. En alternative, isoler le sol nettoyé jusqu'à ce qu'il soit complètement sec.

Pour le nettoyage des sols sur de grandes surfaces, il convient d'utiliser des autolaveuses, pour garantir une hygiène et un nettoyage parfaits.

Le sol doit être considéré comme propre lorsqu'il retrouve son aspect d'origine !

VERLEGUNG

Das gute Gelingen eines Bodenbelags hängt nicht nur von der Qualität der Fliesen ab, sondern von einer ganzen Reihe an Elementen (Untergrund, Bindschicht, Dehnungsfugen,

usw.), die ein Gesamtsystem bilden. Deshalb sind die Verlegungsarbeiten genauso wichtig, wie die Wahl der Fliesen. Der Planer hat die Aufgabe, je nach Struktur und Bestimmungszweck der Bodenfläche die korrekte Fliesen-Verlegungsmethode und die Art der einzusetzenden Fliesen zu bestimmen.

Casalgrande Padana unterscheiden sich in Bezug auf die Verlegungsarbeiten nicht von anderen Keramikprodukten, so dass die Verlegung sowohl auf traditionelle Art mit Zementmörtel als auch mit Leimen oder Klebstoffen erfolgen kann.

Für Formate über 30x30 cm sollte auf ein klebstoffbasiertes Verlegungssystem zurückgegriffen werden. Die Entscheidung für eine bestimmte Methode orientiert sich an der vorgesehenen Umgebung, an Art und Eigenschaften des Untergrunds, am gewünschten Format und an der auf die Fliesen einwirkende statische bzw. dynamische Kraft. Die Verlegung mit Klebstoff erfordert zudem eine Prüfung, ob der Untergrund die entsprechenden Eigenschaften für eine Verklebung von Keramikfliesen besitzt. Entscheidend hierfür sind ein gleichbleibendes, regelmäßiges Flächenmaß, Steifigkeit, keine Risse, saubere Oberfläche frei von Fehlstellen, keine verbleibende Feuchtigkeit und/oder Schadstoffverunreinigungen.

Vor Beginn der Verlegung auf jeglichen Oberflächen ist unbedingt sicher zu stellen, dass das Steinzeug geeignet ist und in der notwendigen Menge und im gewünschten Farbton und Werkmaß zur Verfügung steht. Es müssen zudem alle Vorschriften und Vorkehrungen beachtet werden, die einer korrekten Ausführung der Arbeiten zu Grunde liegen (Vorbereitung des Untergrundes, Zubereitung des Mörtels oder der Kleber, Abbindezeiten, Position der Dehnungsfugen, Anklopfen, usw.).

In großflächigen Bereichen sind unbedingt regelmäßig Dehnungsfugen einzuplanen, während es in kleinen Bereichen genügt, ein wenig Abstand zwischen Fliesenfläche und Randmauern zu lassen. Mit der Sockelleiste wird dieser Abstand dann abgedeckt, um den Boden fertig zu stellen. Nach dem Verlegen darf der Boden mindestens 2-3 Tage nicht begangen werden. Falls ein Begehen notwendig sein sollte, müssen zuvor Planken auf den Boden gelegt werden.

Nach der Verlegung sollte der Bodenbelag bis zum Abschluss der Bauarbeiten angemessen geschützt werden, um Beschädigungen durch

POSA E MANUTENZIONE INSTALLATION AND MAINTENANCE POSE ET ENTRETIEN VERLEGUNG UND PFLEGE

abrasive Substanzen oder andere schädliche Agentien zu vermeiden.

Es ist zu berücksichtigen, dass es bei der Verlegung mit dem traditionellen System und ohne spezielle Zusatzstoffe im Mörtel notwendig ist, sogar einen Monat zu warten, bevor der Boden Beanspruchungen und Betriebslasten ausgesetzt wird. Obwohl es sich bei den Platten von **Casalgrande Padana** um hochresistente Materialien handelt, lassen sie sich für die Installation von technisch-sanitären Anlagen unter Verwendung geeigneter Geräte zuschneiden oder bohren.

lassen, können konzentriertere Reinigungsmittel verwendet werden; diese sollte man für eine angemessene Zeit einwirken lassen und dann angemessen kräftig abreiben, bis die Platten wieder ihr ursprüngliches Aussehen zurück erhalten. Wir weisen darauf hin, dass Steinzeug gegen alle chemischen Mittel beständig ist, mit Ausnahme von Fluorwasserstoffsäure, die alle Keramikprodukte angreift und daher nicht verwendet werden darf.

In öffentlichen Bereichen sollte die Reinigung nach der Schließzeit vorgenommen werden, damit der Boden bei der Wiedereröffnung trocken ist; anderenfalls muss der gereinigte Bereich bis zur kompletten Trocknung abgesperrt werden.

PFLEGE UND REINIGUNG VON BÖDEN UND WANDVERKLEIDUNGEN

Ein Fußboden oder eine Wandverkleidung von **Casalgrande Padana** ist sowohl in der natürlichen wie auch anpolierten, polierten oder geschliffenen Ausführung Ausdruck von Schönheit, Widerstandsfähigkeit und Langlebigkeit.

Die Instandhaltung solcher Beläge verlangt keine besonderen Pflegemaßnahmen, sondern lediglich die Beachtung der folgenden Reinigungsverfahren.

Erstreinigung

Sie dient dazu, nach der Verlegung jegliche Spur von Zement oder Fugenmörtel zu entfernen.

Normalerweise wird sie nur einmal vor der Verwendung des Fußbodens bzw. der Wandverkleidung durchgeführt und sollte nach der Verlegung und vor der Nutzung vorgenommen werden.

Gehen Sie dazu folgendermaßen vor:

1. Den Fußboden/die Verkleidung fegen und den groben Schmutz entfernen.
2. Die Oberfläche mit Wasser befeuchten,

um die Fugen zu imprägnieren und somit vor der ätzenden Wirkung des säurehaltigen Reinigungsmittels (Kalklöser) zu schützen.

3. Das Reinigungsprodukt (*siehe Anmerkung A*) in der vom Hersteller vorgegebenen Konzentration (Mischverhältnis mit Wasser) mit einer Handbürste oder einer motorbetriebenen Bürste auftragen.

Für die Metallica-Serie unbedingt stark verdünnte Reinigungsmittel (Mischverhältnis 1:5, 1 Teil Säure und 5 Teile Wasser) verwenden; dabei muss ganz besonders auf ein ausreichendes Nachspülen und eine vollständige Trocknung des Bodens geachtet werden.

Den Kontakt des säurehaltigen Reinigungsmittels mit etwaigen Komponenten aus Stahl, Aluminium und Naturmarmor, die am Fußboden/an der Wandverkleidung angrenzen, vermeiden.

4. Während der Wirkzeit, die je nach Zustand des Fußbodens festzulegen ist, den hartnäckigsten Schmutz abreiben (und etwaige Mörtel- und Kittrückstände usw. abkratzen).
5. Den Fußboden/die Wandverkleidung mit Wasser abspülen und das Schmutzwasser sofort aufnehmen (von Hand oder mit einer Bodenreinigungsmaschine).

Wenn die Erstreinigung erst nach der Benutzung des Fußbodens/der Wandverkleidung erfolgt, müssen vor der Anwendung des säurehaltigen Reinigungsmittels etwaige Fette oder ähnliche Stoffe mit geeigneten Alkalireinigern (Fettlösern) entfernt werden (*siehe Normale Reinigung*). Falls erforderlich, kann die Erstreinigung wiederholt werden.

Geschliffene, polierte und anpolierte Oberflächen

Ein leichter Glanzverlust bei geschliffenen Oberflächen infolge der ersten säurehaltigen Wäsche des Fußbodens ist als normal zu betrachten, da er auf die Entfernung der Rückstände der für die Oberflächenbearbeitung verwendeten Schleifmittel zurückzuführen ist.

- A** Einige empfohlene Reinigungsmittel zur Entfernung von Mörtelresten:
Verfugung mit Zementfugenmörtel – säurehaltige Reinigungsmittel (Kalklöser)

Deterprimo plus (Casalgrande Padana), Deterdek (Fila), Keranet (Mapei), Deltaplus (Kerakoll), Solvacid (Geal) oder ähnliche Mittel (die Angaben des Reinigungsmittelherstellers beachten).
Verfugung mit Epoxidfugenmörtel – alkalische Reinigungsmittel
Fuga-Soap Eco (Kerakoll), Kerapoxy Cleaner (Mapei), Tile Cleaner (Faber), CR10 (Fila), Lithofin Resin-Ex (Lithofin), Eposolv (Geal) oder ähnliche Mittel (die Angaben des Reinigungsmittelherstellers beachten).

Normale Reinigung

Für die Alltagsreinigung genügt es, den Fußboden/die Wandverkleidung mit Wasser und normalen Reinigungsmitteln für Keramikflächen zu reinigen (für Wandverkleidungen Gels verwenden). Da die Oberflächen der Produkte von **Casalgrande Padana** praktisch nicht aufnahmefähig sind, müssen für ihren Schutz keine Wachse und/oder silikonhaltige Produkte aufgetragen werden. Ganz im Gegenteil sollten diese niemals verwendet werden (sie können einen Oberflächenfilm bilden, der die natürlichen Eigenschaften des Feinsteinzeugs verändert).

Bei beständigen und schwer entfernbaren Flecken, die sich nicht mit einer normalen Reinigung beseitigen lassen, können konzentriertere Reinigungsmittel verwendet werden; diese sollte man für eine angemessene Zeit einwirken lassen und dann angemessen kräftig abreiben, bis die Platten wieder ihr ursprüngliches Aussehen zurückerhalten. Wir weisen darauf hin, dass Steinzeug gegen alle chemischen Mittel beständig ist, mit Ausnahme von Fluorwasserstoffsäure, die alle Keramikprodukte angreift und daher nicht verwendet werden darf.

In öffentlichen Bereichen sollte die Reinigung nach der Schließzeit vorgenommen werden, damit der Boden bei der Wiedereröffnung trocken ist; anderenfalls sollte der gereinigte Bereich bis zur kompletten Trocknung abgesperrt werden.

Für große Räumlichkeiten ist der Einsatz von Reinigungsmaschinen empfehlenswert, um eine perfekte Reinigung und Hygiene sicherzustellen.

Der Bodenbelag gilt als sauber, wenn er wieder sein ursprüngliches Aussehen hat!